



OWNER'S MANUAL
MANUEL DU PROPRIÉTAIRE
USO E MANUTENZIONE
INSTRUKTIONSBOK
OMISTAJAN KÄSIKIRJA
EIERHÅNDBOK

(E)
(F)
(I)
(S)
(SF)
(N)

- (E) ⚠ Read this manual carefully before operating this vehicle.
- (F) ⚠ Il convient de lire attentivement ce manuel avant la première utilisation du véhicule.
- (I) ⚠ Leggere attentamente questo manuale prima di utilizzare questo veicolo.
- (S) ⚠ Läs den här instruktionsboken noga innan snöskotern används.
- (SF) ⚠ Lue tämä käsikirja huolellisesti ennen moottorikelkan käyttöä.
- (N) ⚠ Les denne håndboken nøye før du tar kjøretøyet i bruk.

RS VIKING

VK10F

Original instructions
Notice originale
Istruzioni originali
Bruksanvisning i original
Alkuperäiset ohjeet
Opprinnelige instruksjoner



PRINTED IN JAPAN
2014.04-0.3×1 CR

PRINTED ON RECYCLED PAPER
IMPRIMÉ SUR PAPIER RECYCLÉ
STAMPATO SU CARTA RICICLATA
TRYCKT PÅ ÅTERVUNNET PAPPER
PAINETTU UUSIOPAPERILLE
TRYKKET PÅ RESIRKULERT PAPIR



OWNER'S MANUAL

 Read this manual carefully
before operating this vehicle.

RS VIKING

VK10F

 **Read this manual carefully before operating this vehicle. This manual should stay with this vehicle if it is sold.**

EC Declaration of Conformity

conforming to Directive 2006/42/EC

**We, YAMAHA MOTOR CO., LTD. 2500 Shingai, Iwata, Japan,
declare in sole responsibility, that the product**

VK10D (VK10) (JYE8KB00*FA000001-)

(Make, model)

to which this declaration applies, conforms to the essential health and safety requirements of Directive 2006/42/EC

(If applicable)

and to the other relevant Directive of EEC

2004/108/EC

(Title and/or number and date of issue of the other Directives of EEC)

(If applicable)

To effect correct application of the essential health and safety requirements stated in the Directives of EEC, the following-standards and/or technical specifications were consulted:

(Title and/or number and date of issue of standards and/or specifications)

Authorized Representative

YAMAHA MOTOR EUROPE N.V.

Koolhovenlaan 101, 1119 NC Schiphol-Rijk, The Netherlands

Signature

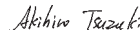

Akihiro Tsuzuki

General Manager

Engineering Div., RV Business Unit

Business Development Operations

YAMAHA MOTOR CO., LTD.

Date of Issue

10 October, 2013

Congratulations on your purchase of a Yamaha snowmobile. This model is the result of Yamaha's vast experience in the production of fine sporting and touring snowmobiles. It represents the high degree of craftsmanship and reliability that have made Yamaha a leader in these fields.

This manual will give you an understanding of the operation, inspection, and basic maintenance of this snowmobile. If you have any questions concerning the operation or maintenance of your snowmobile, please consult a Yamaha dealer.

Yamaha continually seeks advancements in product design and quality. Therefore, while this manual contains the most current product information available at the time of printing, there may be minor discrepancies between your snowmobile and this manual. If there is any question concerning this manual, please consult a Yamaha dealer.

EWS00671

WARNING

Please read this manual carefully before operating this snowmobile. Do not attempt to operate this snowmobile until you have attained adequate knowledge of its controls and operating features.

Regular inspections and careful maintenance, along with good operating techniques, will help ensure that you safely enjoy the capabilities and reliability of this snowmobile.

VK10F

OWNER'S MANUAL

©2014 by Yamaha Motor Co., Ltd.

1st Edition, March 2014

All rights reserved.

Any reprinting or unauthorized use without the written permission of

Yamaha Motor Co., Ltd.

is expressly prohibited.

Printed in Japan.

Important manual information

ESU10152

Particularly important information is distinguished in this manual by the following notations.

 This is the safety alert symbol. It is used to alert you to potential personal injury hazards. Obey all safety messages that follow this symbol to avoid possible injury or death.

EWS00022

 **WARNING** _____
A WARNING indicates a hazardous situation which, if not avoided, could result in death or serious injury.

ECS00012

 **NOTICE** _____
A NOTICE indicates special precautions that must be taken to avoid damage to the snowmobile or other property.

TIP _____
A TIP provides key information to make procedures easier or clearer.

Contents

Location of the important labels.....	1	Pre-operation checks	30
Safety information.....	9	Pre-operation check list.....	30
Description.....	11	Operation.....	32
Control functions.....	13	Starting the engine.....	32
Main switch	13	Break-in	33
Starter (choke) lever	13	Riding your snowmobile	33
Throttle lever	13	Maximizing drive track life	37
Throttle override system		Strap	38
(T.O.R.S.).....	14	Driving.....	38
Multi-function meter unit.....	14	Stopping the engine	39
High beam indicator light	15	Transporting.....	39
Low coolant temperature indicator		Periodic maintenance and	
light	15	adjustment.....	41
Fuel meter and grip/thumb warmer		Periodic maintenance chart for the	
level indicator	16	emission control system.....	42
Fuel level warning indicator	17	General maintenance and	
Oil level warning indicator	18	lubrication chart.....	43
Coolant temperature warning		Tool kit	45
indicator	18	Recommended equipment	45
Self-diagnosis device.....	18	Opening and closing the shroud	
Engine stop switch	19	and removing and installing the	
Headlight beam switch		right side cover	45
“LIGHTS”	19	Checking the spark plugs.....	46
Grip/thumb warmer adjusting		Adjusting the engine idling	
switch.....	19	speed.....	47
Auxiliary DC jack	20	Adjusting the throttle lever free	
Brake lever	20	play	47
Parking brake lever	21	Checking the throttle override	
Shift lever	21	system (T.O.R.S.).....	48
Drive guard.....	22	Checking the air filter.....	49
V-belt holders.....	22	Carburetors.....	50
Carburetor coolant shut-off		High-altitude settings.....	50
lever.....	22	Valve clearance.....	50
Louvers	23	Engine oil and oil filter cartridge ...	50
Passenger grip warmer switch.....	23	Cooling system	55
Storage areas.....	23	V-belt	56
Tow hitch bracket	25	Drive chain housing	59
Fuel	26	Brake and parking brake	60
Suspension	27	Extrovert drive sprocket	63
		Skis and ski runners	63

Contents

Steering system	65
Drive track and slide runners	66
Lubrication	69
Replacing a headlight bulb	70
Adjusting the headlight beams	71
Fittings and fasteners.....	71
Battery.....	71
Replacing a fuse	72
Troubleshooting	75
Storage.....	79
Specifications	81
Consumer information.....	83
Identification number records	83
WARRANTY	83
Index.....	84

Location of the important labels

ESU1267A

Read and understand all of the labels on your vehicle. They contain important information for safe and proper operation of your vehicle. Never remove any labels from your vehicle. If a label becomes difficult to read or comes off, a replacement label is available from your Yamaha dealer.

For EUROPE

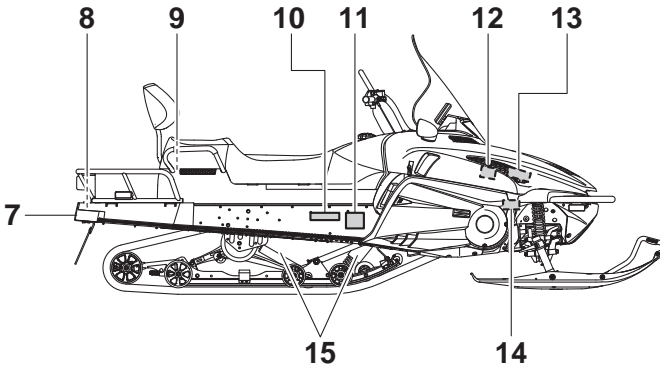
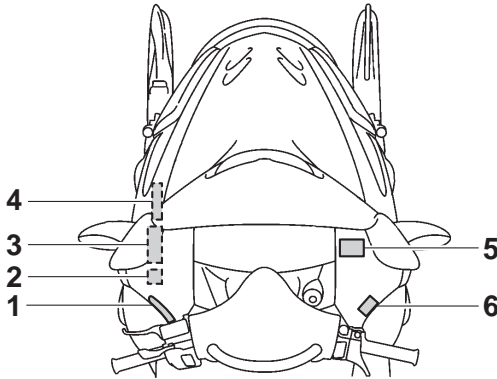

Location of the important labels

1

⚠ VARNING	⚠ VAROITUS
<p>FÖR DIN SÄKERHET OCH UNDVIKANDE AV SKADA BER VI DIG IAKTTA FÖLJANDE:</p> <ul style="list-style-type: none">Läs instruktionsboken och alla skyltar innan Du kör detta fordon.Detta fordon har hög prestanda och får därför endast köras av en erfaren förare.Kontrollera gas, broms och styrning innan Du startar motorn.Dra åt parkeringsbromsen innan Du startar motorn.Kör aldrig med parkeringsbromsen åtdragen.För att slöppa motorn i en nödsituation - tryck ned knappen för nödstopp.Kör inte motorn utan variatorrem eller variatorskydd.Försäkra Dig om att tanklocket är låst ordentligt efter tankning.Använd alltid godkänd hjälm, skoterglasögon och i övrigt lämplig klädsel för skoteråkning.Kontrollera växelspakens läge 'F' (framåt) eller 'R' (back) innan Du kör.	<p>JOUDUT VAKAAN LOUKKAANTUMIS TAI HENGENVAARAAN, ELLETT NÖUDATA SEURAAVIA OHJAJETA:</p> <ul style="list-style-type: none">Lue käyttöajan käsikirja ja kaikki tarat, ennen kuin alat käyttää tätä ajoneuvoa.Tämä on tehokas ja voimakas ajoneuvo.Se on tarkoitettu kokeneille kuljettajille.Tarkista ennen moottorin käynnistystä kaasun, jarrun ja ohjauksen toiminta.Laita seisontajarru päälle, ennen kuin alat käynnistää moottoria.Älä kuitenkaan missään tapauksessa lähde liikkeelle seisontajarru päällä.Hätätilanteissa moottorin voi sammuttaa hätäpysäytinää painamalla.Älä käynnistä moottoria, kun suojukset eivät ole paikallaan.Muista sulkea polttoainesäiliön tulppa huolellin tankkauksen jälkeen.Käytä lumikelkalla ajassesssi hyväksytyä kypärää, suojalaseja ja sopivia vaatteita.Tarkista vaihde vivun asento (eteen tai taakse) ennen liikkeellelähtöä.

8DM-90

8DM-77761-S0

2

⚠ VARNING
Kör aldrig motorn utan variatorrem eller med variatorskyddet borttaget.
⚠ VAROITUS
Älä koskaan käytä kelkkaa ilman variaattorihinaa tai variaattorihinan suojuksen ollessa irti.

86D-77762-00

3

TUNE-UP SPECIFICATIONS	SPECIFICATIONS DE LA MISE AU POINT
DRIVE 1. CHAIN CASE OIL Q'TY <u>350 cm³ (11.8 oz)</u> 2. CHAIN CASE OIL TYPE <u>GL-3 75W or 80W</u> 3. TRACK TENSION <u>30 - 35 mm (1.18 - 1.38 in)/100 N (10 kg, 22 lb)</u>	ENTRAÎNEMENT 1. CAPACITÉ D'HUILE DU CARTER DE CHAÎNE <u>350 cm³</u> 2. TYPE D'HUILE DU CARTER DE CHAÎNE <u>GL-3 75W or 80W</u> 3. FLÊCHE DE LA CHENILLE <u>30 - 35 mm/100 N (10 kg)</u>
* FOR MORE INFO: SEE SERVICE MANUAL FOR THIS MODEL. * SPECIFICATIONS SUBJECT TO CHANGE WITHOUT NOTICE.	* POUR PLUS DE DÉTAIL: VOIR LE MANUEL D'ATELIER POUR CE MODÈLE. * LES CARACTÉRISTIQUES TECHNIQUES SONT SUSCEPTIBLES DE CHANGER SANS NOTIFICATION PRÉALABLE. 8JD-47578-00

4

TUNE-UP SPECIFICATIONS	SPECIFICATIONS DE LA MISE AU POINT
ENGINE 1. SPARK PLUG <u>CR8E(NGK)</u> 2. SPARK PLUG GAP <u>0.7 - 0.8 mm (0.028 - 0.031 in)</u> 3. IDLE SPEED <u>1400 ± 100 r/min</u>	MOTEUR 1. TYPE DE BOUGIE <u>CR8E(NGK)</u> 2. ECARTEMENT DES ÉLECTRODES <u>0.7 - 0.8 mm</u> 3. RÉGIME DE RALENTI <u>1400 ± 100 r/min</u>

8ES-1417E-00

5

⚠ VARNING
Felaktig användning av den STROPP som finns på styrstängan kan resultera i ALLVARLIG KROPPSSKADA eller DÖDSOLYCKA.
Använd stroppen endast som en grepppunkt för föraren vid förskjutning av vikten uppåt i backen för att behålla balansen under tvärgående körning (längs en bergssida).
Håll ena handen på styrstängan.
Ändra inte plötsligt hastighet eller körriktning.
Endast rutinerade förare bör köra tvärgående i backar som är så pass branta att de kräver användning av stroppen.
⚠ VAROITUS
Ohjaustangon HIHNAN viriheellinen käyttö saattaa aiheuttaa VAKAVIA VAMMOJA tai jopa KUOLEMAN.
Käytä hihnaa ainoastaan käyttäjän piko kohtana painon siirtämiseksi ylämääräen tasapainon säilyttämistä varten ajettaessa vinoittain (siivuttain).
Pitä toinen käsi ohjaustangolla.
Älä muuta nopeutta tai suuntaa äkillisesti.
Hihnan käyttöä vaativissa syvissä rinteissä vinoittain ajaminen on suositeltavaa ainoastaan kokeneille käyttäjille.

8FN-77761-S0

6

DUAL RANGE
VÄXLINGINSTRUKTIONER • Växla endast när snöskotern står stilla och motorn går på tomgång. • Dra ut växelspaken och vrid den sedan till önskat läge tills den snäpper på plats. Frigör växelspaken. • Lågväxel får inte användas vid hastigheter över 80 KM/H (50 MPH).
VAIHTAMISOHJEET • Vaihteen saa vaihtaa vain koneen ollessa pysähtyneenä ja moottorin käydessä joutokäyntinä. • Vedä suunnanvaihdinvipua ulos ja käännä sitä haluttuun asentoon niin, että se napsahtaa paikalleen. Vapauta vipu. • Alemmaa nopeusalueetta ei saa käyttää ajattaessa yli 80 KM/H (50 MPH) nopeudella.



8GS-77763-S0

2

Location of the important labels

7

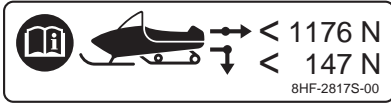

8



9



10

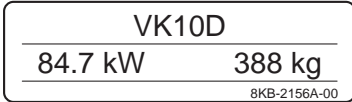

11



12

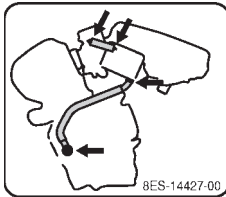

13

<i>MUISTA</i>	<i>VIKTIGT</i>
<p>Öljyn puute voi vaurioittaa moottoria vakavasti, jos kampikammion huoltoinletkuja ei ole kiinnitetty oikein. Tarkista, että letkut ja kiristimet on asennettu kunnolla akun huollon tai imäkammion irrotuksen jälkeen. Katso lisätietoja Huolto-ohjeesta.</p>	<p>Allvarlig motorskada kan uppstå vid oljeförlust om vevhusventilatorns slangar inte monterats korrekt. Kontrollera att slangar och kämmor är korrekt monterade efter batteriservice eller avlägsnande av luftlädan. Se verkstadshandboken.</p>

8GS-2815J-S0

14

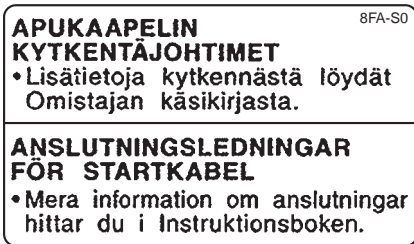





15



Location of the important labels

Familiarize yourself with the following pictograms and read the explanatory text.

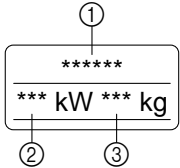
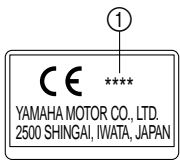
	Read the Owner's manual.
	This unit contains high-pressure nitrogen gas. Mishandling can cause an explosion. Do not incinerate, puncture or open.
	This pictogram shows the sled hitch tow weight limit (combined weight of the sled and all cargo in the sled). Overloading can cause loss of control. Loss of control can result in severe injury or death.
	This pictogram shows the sled hitch tongue weight limit (weight on the sled tongue). Overloading can cause loss of control. Loss of control can result in severe injury or death.
	<ul style="list-style-type: none">① Model Name② Max. Power③ Mass In Running Order
	<ul style="list-style-type: none">① Year of construction

Location of the important labels

For RUSSIA

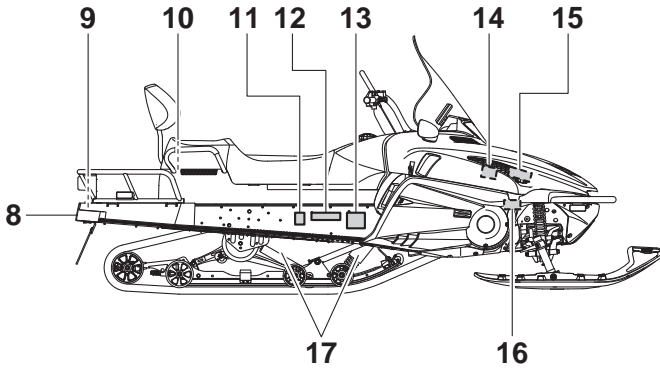
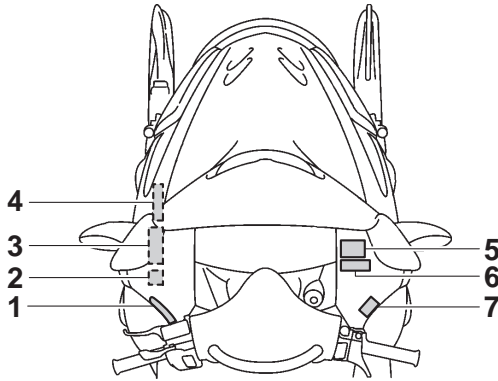

Location of the important labels

1

⚠ ОСТОРОЖНО

НЕВЫПОЛНЕНИЕ ВАМИ ЛЮБОГО ИЗ НИЖЕПЕРЕЧИСЛЕННЫХ ТРЕБОВАНИЙ МОЖЕТ ПРИВЕСТИ К СЕРЬЕЗНОЙ ТРАВМЕ ИЛИ СМЕРТИ :

- Перед эксплуатацией данного транспортного средства прочтите руководство пользователя и все предупреждающие надписи.
- Данный снегоход представляет собой транспортное средство обладающее высокими эксплуатационными характеристиками. Им должны управлять опытные водители.
- Перед запуском двигателя проверьте на работоспособность дроссельную заслонку, тормоз и механизм рулевого управления.
- Прежде, чем попытаться запустить двигатель, включите стояночный тормоз. Ни в коем случае не ездите на снегоходе с включенным стояночным тормозом.
- Для выключения двигателя в экстренной ситуации нажмите на выключатель двигателя.
- Не включайте двигатель без приводного ремня или кожуха привода.
- После заправки топливом убедитесь, что крышка топливного бака плотно закрыта.
- Не ездите на снегоходе по дорогам общественного пользования. Это может привести к столкновению с другим транспортным средством.
- Перед поездкой на снегоходе надевайте надлежащие средства защиты : шлем, защитные очки (щиток) и защитную одежду.
- Перед началом движения проверьте положение рычага (Передний ход или Задний ход).

8GS-77761-R1

2

⚠ ОСТОРОЖНО

**НЕ ВКЛЮЧАЙТЕ ДВИГАТЕЛЬ БЕЗ КЛИНОВОГО
РЕМНЯ ИЛИ КОЖУХА ПРИВОДА.**

8AC-77762-R1

3

TUNE-UP SPECIFICATIONS	SPECIFICATIONS DE LA MISE AU POINT
DRIVE 1. CHAIN CASE OIL Q'TY <u> 350 cm³ (11.8 oz)</u> 2. CHAIN CASE OIL TYPE <u> GL-3 75W or 80W</u> 3. TRACK TENSION <u> 30 ~ 35 mm (1.18 ~ 1.38 in)/100 N (10 kg, 22 lb)</u> * FOR MORE INFO: SEE SERVICE MANUAL FOR THIS MODEL. * SPECIFICATIONS SUBJECT TO CHANGE WITHOUT NOTICE.	ENTRAÎNEMENT 1. CAPACITÉ D'HUILE DU CARTER DE CHAÎNE <u> 350 cm³</u> 2. TYPE D'HUILE DU CARTER DE CHAÎNE <u> GL-3 75W or 80W</u> 3. FLÈCHE DE LA CHENILLE <u> 30 - 35 mm/100 N (10 kg)</u> * POUR PLUS DE DÉTAIL: VOIR LE MANUEL D'ATELIER POUR CE MODÈLE. * LES CARACTÉRISTIQUE TECHNIQUES SONT SUSCEPTIBLES DE CHANGER SANS NOTIFICATION PRÉALABLE.
	<small>8JD-47578-00</small>

4

TUNE-UP SPECIFICATIONS	SPECIFICATIONS DE LA MISE AU POINT ^{8ES}
ENGINE 1.SPARK PLUG <u> CR8E(NGK)</u> 2.SPARK PLUG GAP <u> 0.7 ~ 0.8 mm (0.028 ~ 0.031 in)</u> 3.IDLE SPEED <u> 1400 ± 100 r/min</u>	MOTEUR 1.TYPE DE BOUCHE <u> CR8E(NGK)</u> 2.ECARTEMENT DES ÉLECTRODES <u> 0.7 ~ 0.8 mm</u> 3.RÉGIME DE RALENTI <u> 1400 ± 100 r/min</u>
	<small>8ES-1417E-00</small>

Location of the important labels

5

⚠ ОСТОРОЖНО

Неправильное пользование закрепленным на руле РЕМНЕМ, может стать причиной ТЯЖЕЛОЙ ТРАВМЫ или СМЕРТИ.

- Используйте ремень только как предмет, за который может держаться водитель для смещения веса тела по направлению к вершине холма с целью сохранения равновесия при пересечении склона.
- Одна рука должна оставаться на руле. Не изменяйте резко скорость и направление.
- Пересекать склоны такой крутизны, при которой необходимо пользоваться ремнем, должны только опытные водители.

8FN-77761-R1

6

⚠ ОСТОРОЖНО

- Залуси двигателя при температуре окружающей среды ниже минус 30 °C не гарантируется.
- Ручной аварийный залуси двигателя не предусмотрен.

8JE-77764-R0

7

DUAL RANGE

VÄXLINGINSTRUKTIONER

- Växla endast när snöskotern står stilla och motorn går på tomgång.
- Dra ut växelspaken och vrid den sedan till önskat läge tills den snäpper på plats. Frigör växelspaken.
- Lågväxel får inte användas vid hastigheter över 80 KM/H (50 MPH).

VAIHTAMISOHJEET

- Vaihteen saa vaihtaa vain koneen ollessa pysähtyneenä ja moottorin käydessä joutokäyntiä.
- Vedä suunnanvaihdinvipua ulos ja käännä sitä haluttuun asentoon niin, että se napsahtaa paikalleen. Vapauta vipu.
- Alempaa nopeusalueita ei saa käyttää ajettaessa yli 80 KM/H (50 MPH) nopeudella.



8GS-77763-S0

8



8HF-2817S-00

9

MAX.BELASTNING/RASKAIN TAAKKA

20kg {44lbs}

8FM-24897-11

10

MAX.BELASTNING/RASKAIN TAAKKA

5kg {11lbs}

8FN-24897-10

Location of the important labels

11



12

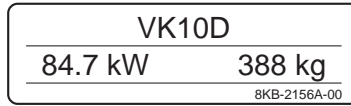

13



14

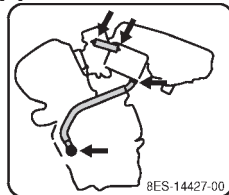

15



16



17



ESU10204

As the vehicle's owner, you are responsible for the safe and proper operation of your snowmobile. When you ride your snowmobile, you must know and use the following for your safety. Severe injury or death may result if you ignore any of the following.

Before you operate your snowmobile

- Read the Owner's Manual and all labels. Become familiar with all of the operating controls and their function. Consult a Yamaha dealer about any control or function you do not understand.
- Wear protective clothing. Wear an approved helmet, and a face shield or goggles. Also, wear a good quality snowmobile suit, boots, and a pair of gloves or mittens that will permit use of your thumbs and fingers for operation of the controls.



- Do not operate the snowmobile after or while drinking alcohol or taking drugs. Your ability to operate the snowmobile is reduced by the influence of alcohol or drugs.

Prepare your snowmobile

- Perform the pre-operation checks each time you use the vehicle to make sure it is in safe operating condition. Failure to inspect or maintain the vehicle properly in-

creases the possibility of an accident or equipment damage. See page 30 for a list of pre-operation checks.

- Apply the parking brake before starting the engine. Never drive the snowmobile with the parking brake applied. This may overheat the brake disc and reduce braking ability.

While using your snowmobile

- This snowmobile was not manufactured for use on public streets, roads, or highways. Such use is prohibited by law, and you could collide with another vehicle.
- Be careful where you ride. There may be obstacles hidden beneath the snow. Stay on established trails to minimize your exposure to hazards. Ride slowly and cautiously when you ride off of established trails. Hitting a rock or stump, or running into wires could cause an accident and injury.
- This snowmobile is not designed for use on surfaces other than snow or ice. Use on dirt, sand, grass, rocks, or bare pavement may cause loss of control and may damage the snowmobile.
- Always ride with other snowmobilers when going on a ride. You may need help if you run out of fuel, have an accident, or damage your snowmobile.
- Many surfaces such as ice and hard-packed snow require much longer stopping distances. Be alert, plan ahead and begin decelerating early. The best braking method on most surfaces is to release the throttle and apply the brake gently—not suddenly.

Avoid carbon monoxide poisoning

All engine exhaust contains carbon monoxide, a deadly gas. Breathing carbon monoxide can cause headaches, dizziness, drowsiness, nausea, confusion, and eventu-

Safety information

ally death. Carbon monoxide is a colorless, odorless, tasteless gas which may be present even if you do not see or smell any engine exhaust. Deadly levels of carbon monoxide can collect rapidly and you can quickly be overcome and be unable to save yourself. Also, deadly levels of carbon monoxide can linger for hours or days in enclosed or poorly-ventilated areas. If you experience any symptoms of carbon monoxide poisoning, leave the area immediately, get fresh air, and SEEK MEDICAL TREATMENT.

- Do not run the engine indoors. Even if you try to ventilate engine exhaust with fans or open windows and doors, carbon monoxide can rapidly reach dangerous levels.
- Do not run the engine in poorly ventilated or partially enclosed areas such as barns, garages, or carports.
- Do not run the engine outdoors where engine exhaust can be drawn into a building through openings such as windows and doors.

Genuine Yamaha Accessories

Choosing accessories for your snowmobile is an important decision. Genuine Yamaha Accessories, which are available only from a Yamaha dealer, have been designed, tested, and approved by Yamaha for use on your snowmobile. Many companies with no connection to Yamaha manufacture parts and accessories or offer other modifications for Yamaha vehicles. Yamaha is not in a position to test the products that these aftermarket companies produce. Therefore, Yamaha can neither endorse nor recommend the use of accessories not sold by Yamaha or modifications not specifically recommended by Yamaha, even if sold and installed by a Yamaha dealer.

Maintenance and storage

- When laying the snowmobile on its side for maintenance, use a suitable stand to keep it in a stable and level position.
- Do not leave the snowmobile on its left side for an extended period of time. Fuel may leak out from the fuel breather hose.
- Do not allow anyone to stand behind the snowmobile when starting, inspecting, or adjusting the snowmobile. A broken track, track fittings, or debris thrown by the track could be dangerous to the operator or bystanders.
- Modifications made to the snowmobile not approved by Yamaha, or the removal of original equipment may render your snowmobile unsafe for use, which may cause severe personal injury. Modifications may also make the snowmobile illegal to use.
- Never store the snowmobile with fuel in the fuel tank inside a building where ignition sources are present such as hot water and space heaters, an open flame, sparks, clothes dryers, and the like. Allow the engine to cool off before storing the snowmobile in an enclosed space.

ESU10262

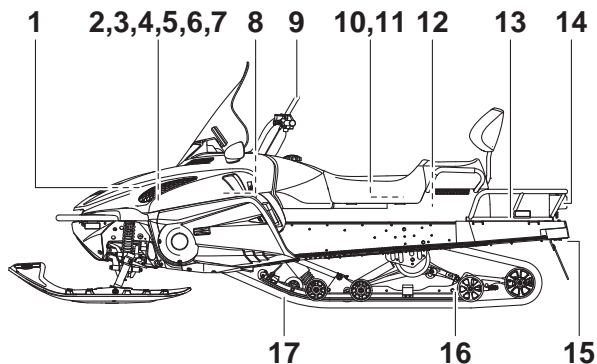

- | | |
|-------------------------|----------------------------------|
| 1. Air filter | 12. Passenger grip warmer switch |
| 2. Battery | 13. Rear carrier |
| 3. Coolant reservoir | 14. Tail/brake light |
| 4. Fuse box | 15. Tow hitch bracket |
| 5. Throttle stop screw | 16. Slide rail suspension |
| 6. Main fuse | 17. Drive track |
| 7. Oil filler cap | |
| 8. V-belt holder | |
| 9. Strap | |
| 10. Storage compartment | |
| 11. Tool kit | |

Description

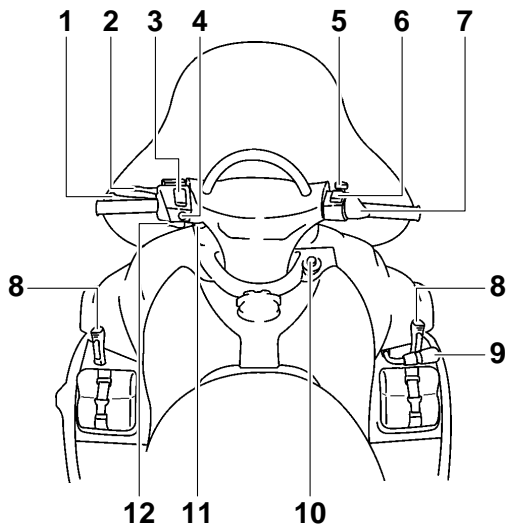

- | | |
|----------------------------------|---------------------------|
| 1. Brake lever | 8. Shroud latch |
| 2. Parking brake lever | 9. Shift lever |
| 3. Grip warmer adjusting switch | 10. Main switch |
| 4. Headlight beam switch | 11. Auxiliary DC jack |
| 5. Engine stop switch | 12. Starter (choke) lever |
| 6. Thumb warmer adjusting switch | |
| 7. Throttle lever | |

TIP

- The snowmobile you have purchased may differ slightly from those shown in the figures of this manual.
 - Design and specifications are subjected to change without notice.
-

ESU12692

Main switch

The main switch controls the ignition and lighting systems. The various positions are described below.

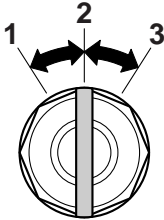

1. Off
2. On
3. Start

Off

The ignition circuit is switched off.
The key can be removed only in this position.

On

The ignition circuit is switched on.

Start

The starting circuit is switched on.
The starter motor cranks the engine.

NOTICE: Release the switch immediately after the engine starts. [ECS00022]

TIP

The headlights, meter lighting, and taillight come on after the engine is started.

ESU10302

Starter (choke) lever

Use the starter (choke) lever when starting and warming up a cold engine.

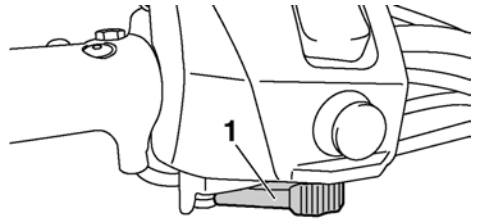

1. Starter (choke) lever

TIP

Refer to the “Starting the engine” section on page 32 for proper operation.

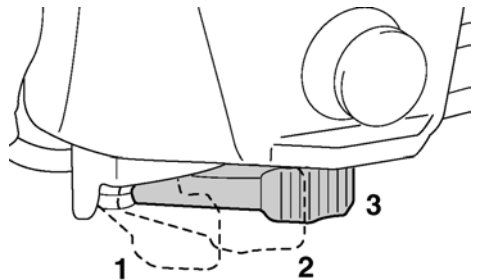

1. When starting a cold engine.
2. Warming up
3. When the engine is warm.

ESU10313

Throttle lever

Once the engine is running cleanly, squeezing the throttle lever will increase the engine speed and cause engagement of the drive train. Regulate the speed of the snowmobile by varying the throttle position. Because the throttle is spring-loaded, the snowmobile will decelerate, and the engine will return to idle when it is released.

Control functions

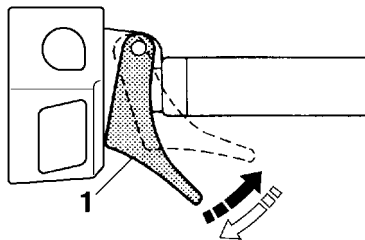

1. Throttle lever

ESU10335

Throttle override system (T.O.R.S.)

EWS00042



If the T.O.R.S. is activated, make sure that the cause of the malfunction has been corrected and that the engine can be operated without a problem before restarting the engine. Continuing to operate with a malfunction could cause loss of control or damage.

If the throttle valves or throttle cable malfunctions during operation, the T.O.R.S. will be activated when the throttle lever is released. The T.O.R.S. is designed to override the ignition and limit the engine speed to less than the clutch engagement speed if the throttle valves fail to return to the idle position when the throttle lever is released. (See page 81 for the clutch engagement speed.)

	Idling	Riding	Malfunction
Throttle lever	Released	Squeezed	Released
Throttle valve	Closed	Open	Open
T.O.R.S.	Engine runs properly.	Engine runs properly.	T.O.R.S. will be activated.

TIP

If the T.O.R.S. is activated, the warning light and engine trouble warning indicator will flash, and the two-digit code "84" will flash in the meter display. If this occurs, have a Yamaha dealer check the system as soon as possible.

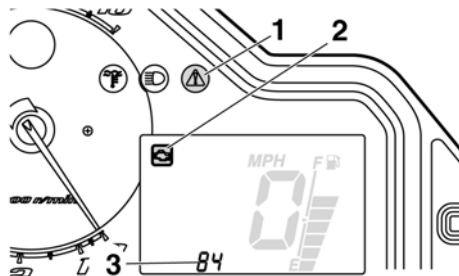

1. Warning light "⚠"
2. Engine trouble warning indicator "🛑"
3. Two-digit code "84"

ESU10357

Multi-function meter unit

The multi-function meter unit is equipped with the following:

- a digital speedometer
- a tachometer
- an odometer
- a tripmeter (which shows the distance traveled since it was last set to zero)
- warning indicators (which show engine trouble, coolant temperature, fuel level, and oil level warnings)
- indicator lights (which show high beam and low coolant temperature conditions)
- a warning light (which shows warnings together with the warning indicators)
- a fuel meter (which shows the fuel remaining in the fuel tank)
- a grip/thumb warmer level indicator (which shows the grip warmer level or the thumb warmer level)

Control functions

After the engine is started, the tachometer makes one sweep, and the low coolant temperature indicator light, the warning light, and all segments of the meter display come on and go off.

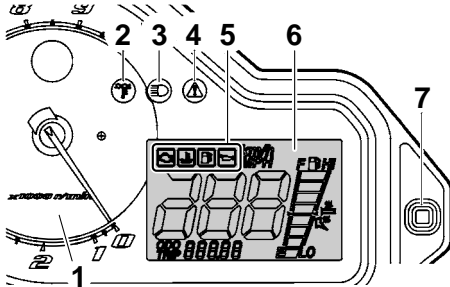

1. Tachometer
2. Low coolant temperature indicator light “”
3. High beam indicator light “”
4. Warning light “”
5. Warning indicators
6. Meter display
7. Select/reset button

The grip warmer level is initially displayed for 5 seconds, then the display switches to the fuel meter.

Odometer and tripmeter modes

Pushing the select/reset button switches the display between the odometer mode “ODO” and the tripmeter mode “TRIP” in the following order:

ODO → TRIP → ODO

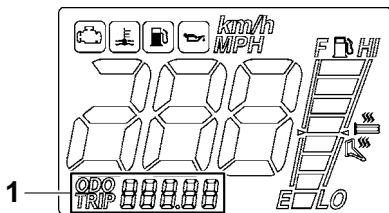

1. Odometer/tripmeter

To reset the tripmeter, push the select/reset button for at least one second while the tripmeter is displayed.

TIP

To switch the speedometer, odometer, and tripmeter displays between kilometers and miles, select the odometer mode “ODO”, and then push the select/reset button for at least 10 seconds while the snowmobile is stopped.

ESU10412

High beam indicator light “”

The high beam indicator light comes on when the high beams of the headlights are switched on. (See page 19 for headlight beam switch operation.)

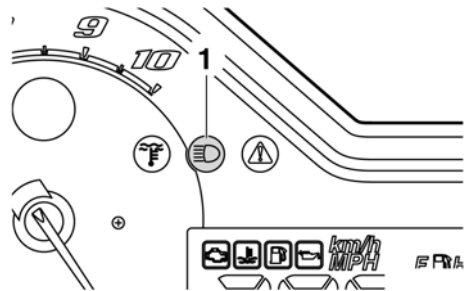

1. High beam indicator light “”

ESU10485

Low coolant temperature indicator light “”

The low coolant temperature indicator light comes on when the coolant temperature is low and informs the rider that the snowmobile should be warmed up. After the engine is started, warm it up until the indicator light goes off.

The snowmobile can be operated normally after the indicator light goes off.

Control functions

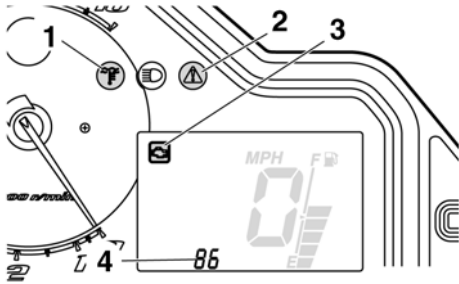

1. Low coolant temperature indicator light “F”
2. Warning light “⚠”
3. Engine trouble warning indicator “🏎️”
4. Two-digit code “86”

TIP

Drive the snowmobile at low speeds when the low coolant temperature indicator light is on. If the engine speed is too high, the warning light and engine trouble warning indicator will flash and the two-digit code “86” will flash in the tripmeter/odometer display. When this occurs, maximum engine speed is reduced to protect the engine.

ESU10428

Fuel meter and grip/thumb warmer level indicator

The fuel meter and grip/thumb warmer level indicator have eight segments which show the amount of fuel remaining in the fuel tank, the grip warmer level, or the thumb warmer level.

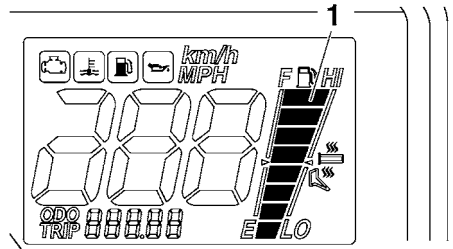

1. Fuel meter and grip/thumb warmer level indicator

Fuel meter

The display segments of the fuel meter disappear towards “E” (Empty) as the fuel level decreases. When only one segment is left near “E”, the fuel level warning indicator and the warning light come on.

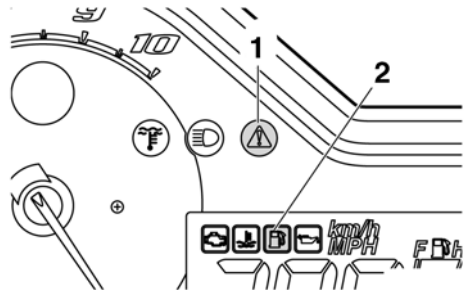

1. Warning light “⚠”
2. Fuel level warning indicator “🛢️”

If the fuel level warning indicator and the warning light come on, refuel as soon as possible.

TIP

The snowmobile must be stopped on a level surface to obtain an accurate fuel meter reading, since the reading changes according to the movement and inclination of the snowmobile.



Grip/thumb warmer level indicator

When the grip warmer adjusting switch is pressed, the grip warmer indicator comes on and the display switches to the grip warmer level.

When the thumb warmer adjusting switch is pressed, the thumb warmer indicator comes on and the display switches to the thumb warmer level.

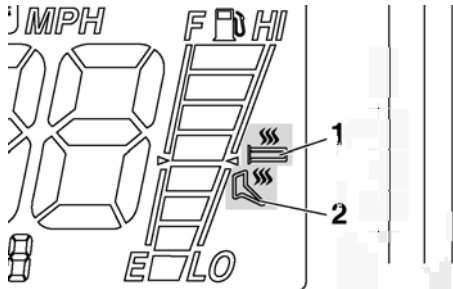
See “Grip/thumb warmer adjusting switch” on page 19 for detailed information.



1. Grip warmer indicator “”
2. Thumb warmer indicator “”

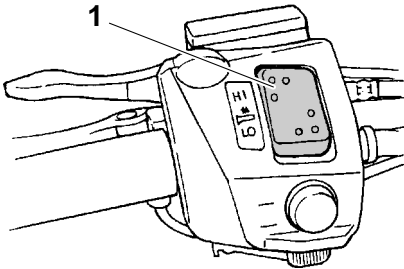

1. Grip warmer adjusting switch

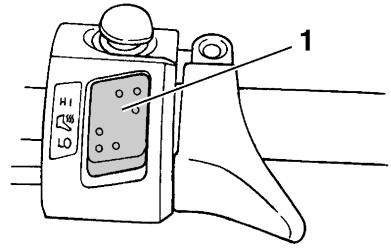

1. Thumb warmer adjusting switch

TIP

- The grip/thumb warmer level is displayed for 5 seconds after releasing the grip/thumb warmer adjusting switch, then the display switches to the fuel meter.
- The top segment of the grip/thumb warmer level indicator flashes once when the grip/thumb warmer adjustment reaches the maximum level. The bottom segment of the grip/thumb warmer level indicator flashes once when the grip/thumb warmer adjustment reaches the minimum level.
- When the engine is started, the grip/thumb warmer levels are set to the levels selected when the engine was last stopped.

ESU10456

Fuel level warning indicator “”



The fuel level warning indicator and the warning light come on when the fuel level is low. (See page 16 for details.)

The fuel level warning indicator, the warning light, and all segments of the fuel meter start to flash when a malfunctioning sensor, disconnected coupler, broken lead, or short circuit is detected by the self-diagnosis device of the snowmobile to warn the rider of any of the above problems.

Control functions

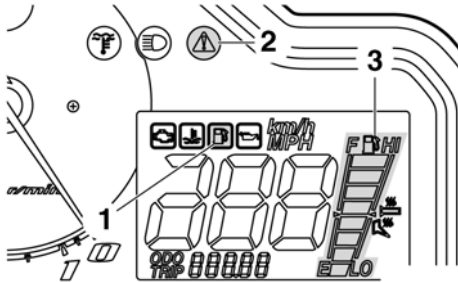
If the fuel level warning indicator, the warning light, and all segments of the fuel meter flash, have a Yamaha dealer inspect the snowmobile as soon as possible.





1. Fuel level warning indicator “”
2. Warning light “”
3. Fuel meter

ESU10464

Oil level warning indicator “”

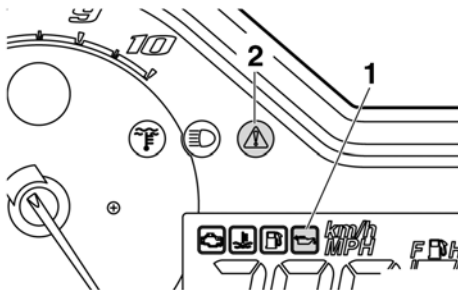
The oil level warning indicator and the warning light come on when the engine oil level is low.



1. Oil level warning indicator “”
2. Warning light “”

If the oil level warning indicator and the warning light come on, place the snowmobile on a level surface and allow it to idle for one minute.

If the oil level warning indicator and the warning light go off, the engine oil level is sufficient, however it is getting low. Add engine oil as soon as possible.

If the oil level warning indicator and the warning light do not go off, check the engine oil level in the oil tank (see page 50 for engine oil level checking procedures), and add engine oil if necessary.



If the oil level warning indicator and the warning light still remain on, have a Yamaha dealer check the snowmobile.

ESU10514

Coolant temperature warning indicator “”

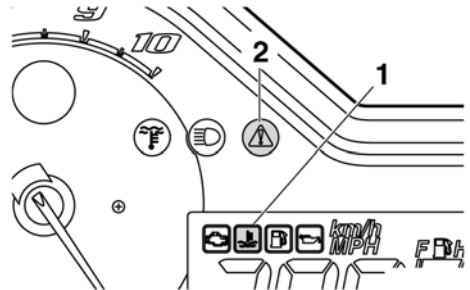
If the engine overheats, the coolant temperature warning indicator and the warning light come on. When this occurs, stop the engine immediately and allow the engine to cool down, and then check the coolant level in the coolant reservoir. (See page 55 for checking procedures.)



1. Coolant temperature warning indicator “”
2. Warning light “”

ECS00042

NOTICE

Do not continue to operate the engine if it is overheating.

ESU12687

Self-diagnosis device

This model is equipped with a self-diagnosis device for various electrical circuits.

If a problem is detected in any of those circuits, the warning light and the engine trouble warning indicator flash, and an error code flashes slowly in the meter display. Note the

error code, and then have a Yamaha dealer inspect the snowmobile as soon as possible.

NOTICE: Do not continue to operate the engine longer than necessary if there is an error code to avoid possible engine damage. [ECS00821]

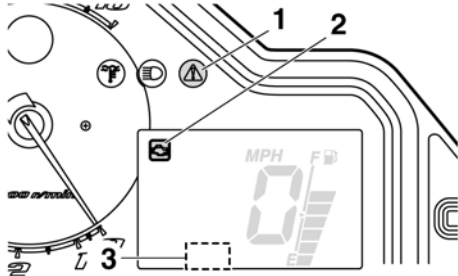

1. Warning light “

ESU10532

Engine stop switch “ The engine stop switch is used to stop the engine in an emergency. Simply push the stop switch to stop the engine. To start the engine, pull the stop switch and proceed with starting the engine. (See page 32 for engine starting procedures.)

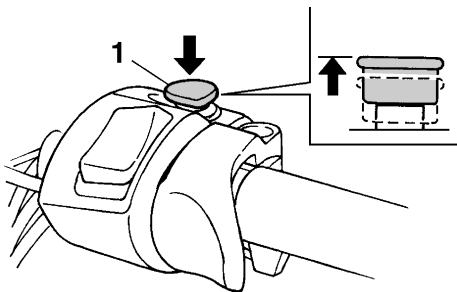

1. Engine stop switch “

During the first few rides, practice using the stop switch so that you can react quickly in an emergency.

ESU10662

Headlight beam switch “LIGHTS”

Push the headlight beam switch to change the headlight to high beam “HI” or to low beam “LO”.

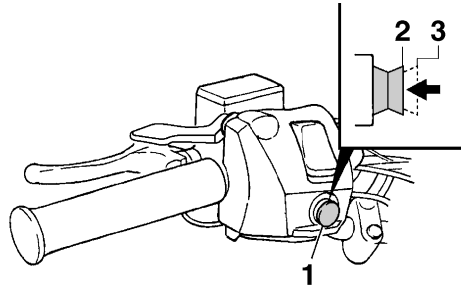

1. Headlight beam switch “LIGHTS”
2. High beam “HI”
3. Low beam “LO”

ESU12655

Grip/thumb warmer adjusting switch

The grip warmer adjusting switch and the thumb warmer adjusting switch control the electrically heated handlebar grips and throttle lever respectively.

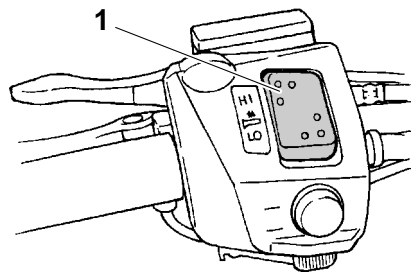

1. Grip warmer adjusting switch

Control functions

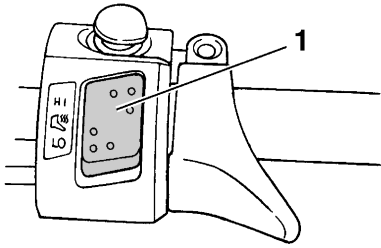

1. Thumb warmer adjusting switch

To raise the temperature

To raise the temperature, press the respective switch to "HI".

To lower the temperature

To lower the temperature, press the respective switch to "LO".

See "Fuel meter and grip/thumb warmer level indicator" on page 16 for detailed information.

ESU10697

Auxiliary DC jack

The auxiliary DC jack is located in the front panel and can be used for accessories.

TIP

The auxiliary DC jack can only be used if the engine is running.

To use the auxiliary DC jack

1. Start the engine.
2. Open the auxiliary DC jack cap, and then insert the accessory power plug into the jack.

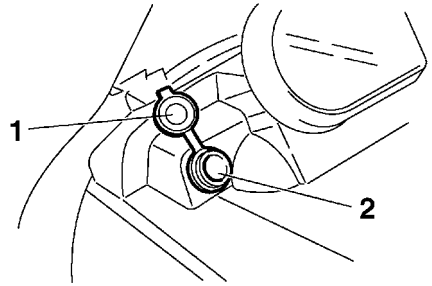

1. Auxiliary DC jack cap
2. Auxiliary DC jack
3. After using the auxiliary DC jack, be sure to remove the accessory power plug from the jack and to close the auxiliary DC jack cap.

ECS00123

NOTICE

- To avoid circuit overload and a possible fuse blowing, do not use accessories requiring more than the maximum rated capacity for the auxiliary DC jack. (See page 72 for the specified fuse amperage.)
- Do not use an automotive cigarette lighter or other accessory with a plug that gets hot because the jack can be damaged.

Maximum rated capacity:
DC 12 V, 2.5 A (30 W)

ESU10552

Brake lever

The snowmobile is stopped by braking the entire drive system.

Squeeze the brake lever towards the handlebar grip to stop the snowmobile.

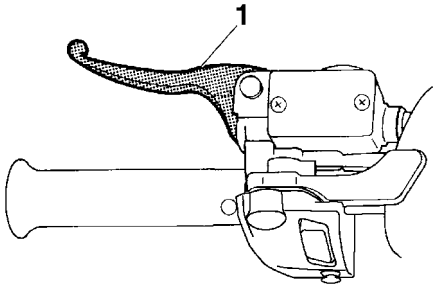

1. Brake lever

TIP

When the brake lever is squeezed, the brake light comes on.

ECS00061

NOTICE

Make sure that the brake lever end does not project out over the handlebar end. This will help prevent brake lever damage when the snowmobile is placed on its side for service.

ESU10582

Parking brake lever

When parking the snowmobile or starting the engine, apply the parking brake by moving the parking brake lever to the left.

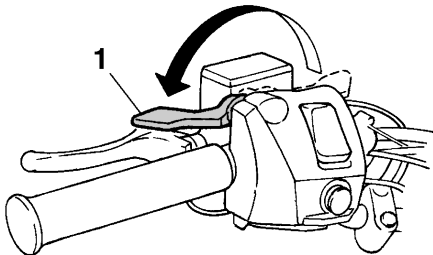

1. Parking brake lever

To release the parking brake, move the parking brake lever to the right.

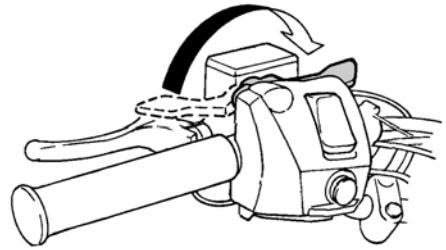

ESU12563

Shift lever

The shift lever is used to shift your snowmobile into drive, reverse, or low. After coming to a complete stop, pull the shift lever out, turn it to the desired position ("D", "R", or "L"), and then release it.

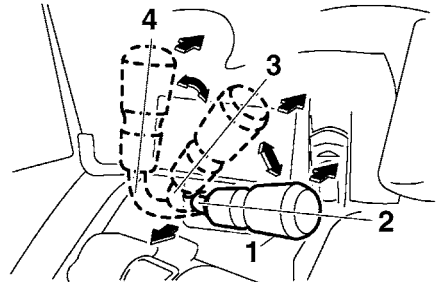

1. Shift lever
2. "D" Drive (forward)
3. "R" Reverse
4. "L" Low (forward)

TIP

Make sure that the shift lever is completely shifted into position.

ECS00073

NOTICE

Do not use the shift lever while the snowmobile is moving, otherwise the drive train could be damaged.

Control functions

ESU10754

Drive guard

EWS00403

WARNING

- Coming in contact with the rotating V-belt or clutch parts can cause severe injury or death. Never run the engine with the drive guard removed.
- Make sure that the drive guard is installed securely before operating the snowmobile to protect against severe injury or death from a broken V-belt or other part should it come off the snowmobile while it is in operation.

ECS00831

NOTICE

Never run the engine with the V-belt removed. Clutch components can be damaged.

The drive guard is designed to cover the V-belt clutch and V-belt in case parts break or come loose.

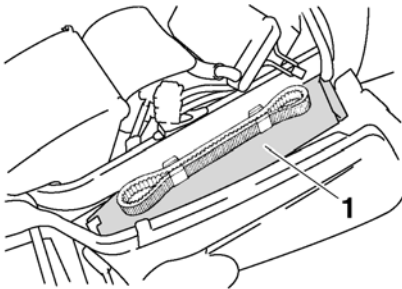

1. Drive guard

ESU10762

V-belt holders

Keep a spare V-belt for emergency use by placing it into the V-belt holders provided.

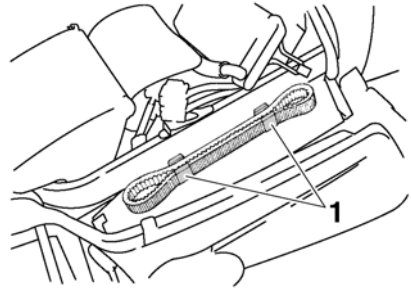

1. V-belt holder

ECS00181

NOTICE

Make sure that the V-belt is installed securely in the holders.

ESU10781

Carburetor coolant shut-off lever

The carburetor coolant shut-off lever controls the flow of coolant through the carburetor. Make sure that the lever is in the “ON” position to allow the coolant to flow and warm the carburetor while the ambient temperature is below 0 °C (32 °F).

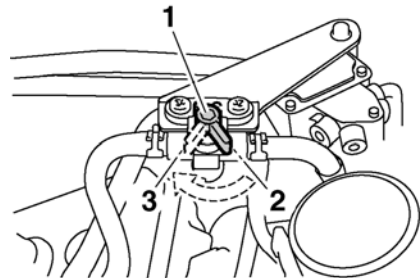

1. Carburetor coolant shut-off lever
2. “ON” (open) position
3. “OFF” (closed) position

ECS00201

NOTICE

When operating the snowmobile in temperatures above 0 °C (32 °F), move the carburetor coolant shut-off lever to the “OFF”

position to stop the flow of coolant, since the carburetor does not need to be warmed.

ESU14351

Louvers

This snowmobile is equipped with louvers for ventilation located in the shroud and the lower front cover.

The upper left louver has a steel plate that can be installed or removed depending on the riding conditions. When operating the snowmobile in areas where the ambient temperature is 5 °C (41.5 °F) or higher, the steel plate can be removed as needed by removing the screws. Before removing the steel plate, consult a Yamaha dealer.

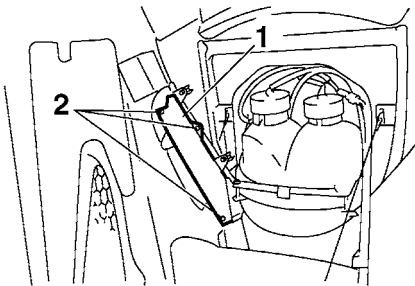

1. Steel plate
2. Screw

ESU10682

Passenger grip warmer switch

The passenger grip warmer switch controls the electrically heated passenger grips.

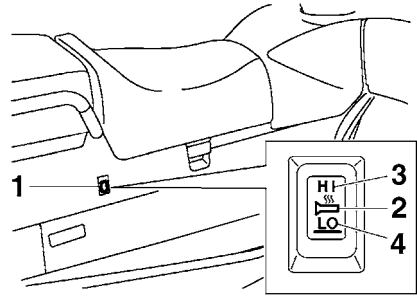

1. Passenger grip warmer switch
2. Off
3. "HI" (high)
4. "LO" (low)

ESU10832

Storage areas

This snowmobile is equipped with a storage compartment, storage pouches, rear storage area, and rear carrier.

Storage compartment

The storage compartment is located under the rider seat.

Use the storage compartment to store the tool kit, spare parts, and other small items. The storage compartment extends under the fuel tank, so it can also be used to store long items such as tools.

To open the rider seat, pull the seat latch, and then slowly raise the seat until it stops.

To close the seat, slowly lower it to its original position, and then push down on the right side of the seat to lock it in place.

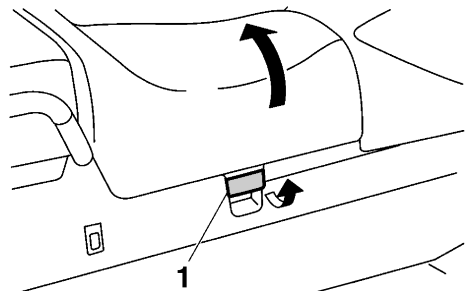

1. Seat latch

Control functions

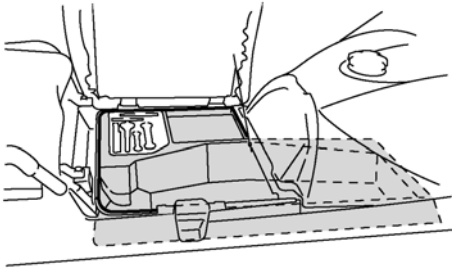

ECS00221

NOTICE

- Do not place sharp items in the storage compartment. Fuel could leak if the fuel tank is damaged.
- The bottom of the storage compartment may be hot during or immediately after operating the snowmobile. It can cause burns if it becomes extremely hot. Furthermore, heat in the storage compartment can affect the quality of food items, and deform and discolor plastic items.

Storage pouches

The storage pouches are located above the rider footrests.

Use the storage pouches to store spare parts and other small items.

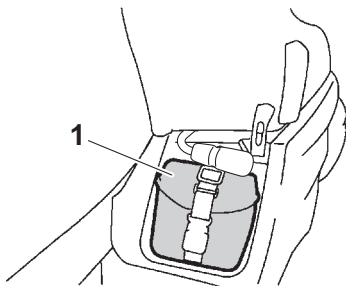

1. Storage pouch

Maximum load limit:
0.3 kg (0.7 lbs)

Rear storage area and rear carrier

The rear storage area and the rear carrier are located at the rear of the snowmobile.

The rear storage area is located under the passenger seat and it can be used only when the seat and backrest are removed.

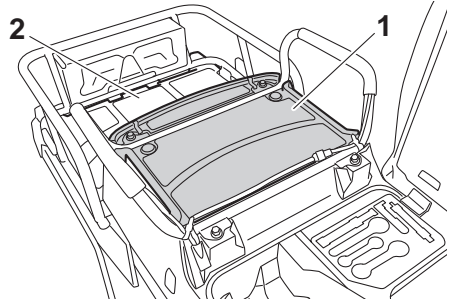

1. Rear storage area
2. Rear carrier

Maximum load limit:
Rear storage area:
5 kg (11 lbs)
Rear carrier:
20 kg (44 lbs)

EWS00141

WARNING

Do not use the rear carrier to lift the snowmobile. The snowmobile could fall, which could result in severe injury or death.

To remove the passenger seat and backrest

1. Open the rider seat. (See “Storage compartment” for details.)
2. Remove the passenger seat bolts, slide the passenger seat and backrest slightly rearward, and then lift them straight up to remove them.

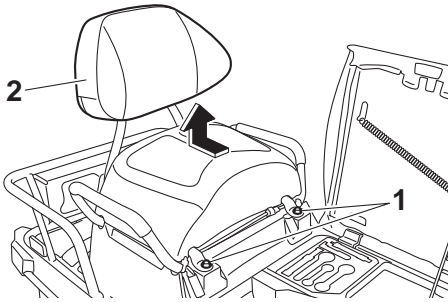

1. Passenger seat bolt
2. Passenger seat and backrest
3. Install the passenger seat bolts, and then tighten them to the specified torque. **NOTICE:** When using the rear storage area, do not load any cargo that is too large for it. In addition, cargo must not project from the edges of the rear storage area. [ECS00212]

Passenger seat bolt tightening torque:
48 Nm (4.8 m·kgf, 35 ft·lbf)

To install the passenger seat and backrest

1. Open the rider seat. (See “Storage compartment” for details.)
2. Remove the passenger seat bolts, insert the hooks on the bottom of the passenger seat and backrest into the slots in the rear storage area, and then slide the seat and backrest forward. **NOTICE:** Make sure that the wire harness is not pinched when installing the passenger seat and backrest. [ECS00232]

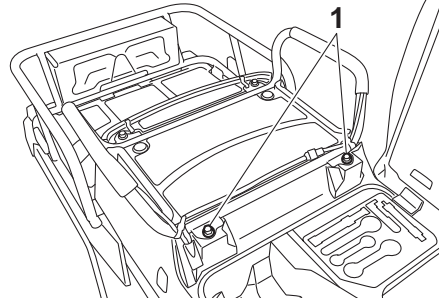

1. Passenger seat bolt

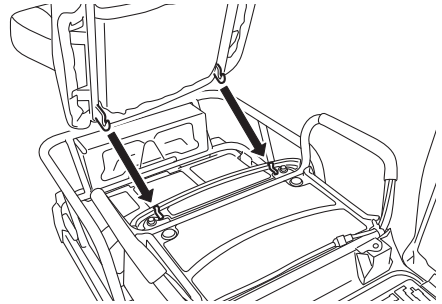

3. Install the passenger seat bolts, and then tighten them to the specified torque.

ESU10864

Tow hitch bracket

ECS00242

NOTICE

To prevent premature wear of the V-belt, avoid traveling under 10 km/h (6 mi/h) when towing for long distances or long periods of time.

This snowmobile is equipped with a tow hitch bracket that is used to install a tow hitch. Use the tow hitch bracket within the specified weight limits.

Control functions

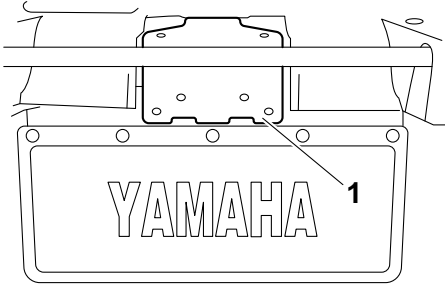

1. Tow hitch bracket

TIP

A tow hitch is available at a Yamaha dealer.

Tow weight limit:
120 kgf (264 lbf)
Vertical weight limit:
15 kgf (33 lbf)

ESU10619

Fuel

EWS00072

WARNING

Gasoline and gasoline vapors are extremely flammable. To avoid fires and explosions and to reduce the risk of injury when refueling, follow these instructions.

Make sure there is sufficient gasoline in the tank.

1. Before refueling, turn off the engine and be sure that nobody is on the snowmobile. Never refuel while smoking, or while in the vicinity of sparks, open flames, or other sources of ignition such as the pilot lights of water heaters and clothes dryers.
2. Do not overfill the fuel tank. Stop filling when the fuel reaches the bottom of the filler tube. Because fuel expands when it heats up, heat from the engine or the sun can cause fuel to spill out of the fuel tank.

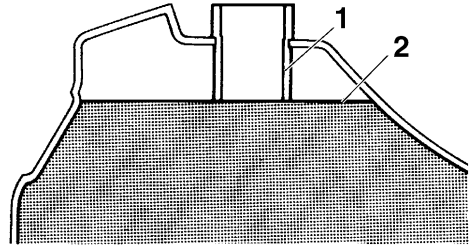
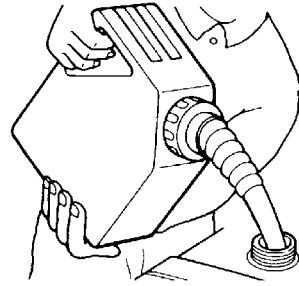

1. Filler tube
2. Maximum fuel level
3. Wipe up any spilled fuel immediately.
4. Be sure the fuel tank cap is closed securely by turning it clockwise.

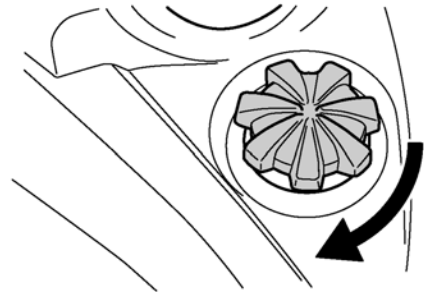

EWS00681

WARNING

Gasoline is poisonous and can cause injury or death. Handle gasoline with care. Never siphon gasoline by mouth. If you should swallow some gasoline or inhale a lot of gasoline vapor, or get some gasoline

in your eyes, see your doctor immediately. If gasoline spills on your skin, wash with soap and water. If gasoline spills on your clothing, change your clothes.

Recommended fuel:
Min 91 RON UNLEADED GASOLINE ONLY (RUS)
Min 95 RON UNLEADED GASOLINE ONLY (FIN)(SWE)
Fuel tank capacity:
40.0 L (10.57 US gal, 8.80 Imp.gal)

Your Yamaha engine has been designed to use unleaded gasoline with a research octane number of 95 or higher. (For Russia, regular unleaded gasoline with a pump octane number $[(R+M)/2]$ of 86 or higher, or a research octane number of 91 or higher.)

ECS00095

NOTICE

- **Make sure that snow or ice does not enter the fuel tank when refueling.**
- **The fuel tank should be filled with the recommended gasoline. The use of other gasoline will cause severe damage to internal engine parts, such as the valves and piston rings, as well as to the exhaust system.**

ESU10875

Suspension

The suspension can be adjusted to suit rider preference. Softer settings, for example, may provide greater rider comfort, while harder settings may allow more precise handling and control over certain types of terrain or riding conditions.

If you are not familiar with suspension adjustments, have a Yamaha dealer make these adjustments.

EWS00152

WARNING

Read and understand the following information before handling shock absorbers that contain highly pressurized nitrogen gas.

- **Do not tamper with or attempt to open the cylinder assemblies.**
- **Do not subject the shock absorbers to an open flame or other high heat source. This may cause the unit to explode due to excessive gas pressure.**
- **Do not deform or damage the cylinders in any way. Cylinder damage will result in poor damping performance.**
- **Do not dispose of a damaged or worn out shock absorber yourself. Take the shock absorber to a Yamaha dealer for any service.**

ESU10885

Adjusting the spring preload of the front shock absorbers

EWS00721

WARNING

The spring preload of the left and right shock absorbers must be adjusted to the same setting. Uneven settings can cause poor handling and loss of stability.

The spring preload can be adjusted by turning the adjusting rings.

To increase the spring preload and thereby harden the suspension, turn the adjusting ring in direction (a). To decrease the spring preload and thereby soften the suspension, turn the adjusting ring in direction (b).

Control functions

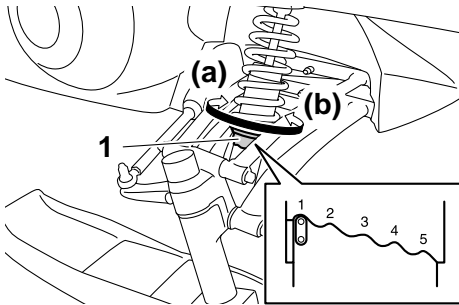

1. Spring preload adjusting ring

Spring preload setting:

Minimum (soft):

1

Standard:

1

Maximum (hard):

5

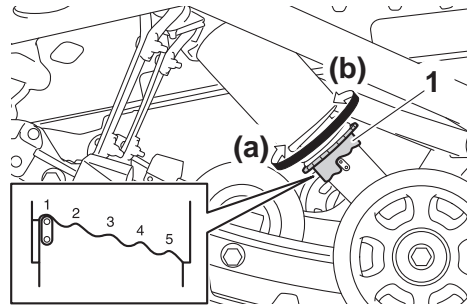

1. Spring preload adjusting ring

Spring preload setting:

Minimum (soft):

1

Standard:

1 (For EUROPE)

3 (For RUSSIA)

Maximum (hard):

5

ESU14321

Adjusting the spring preload of the center shock absorber and the rear torsion springs

The spring preload can be adjusted by turning the adjusting ring on the center shock absorber and the adjusters on the rear torsion springs. Adjust the spring preload as follows.

Center shock absorber

To increase the spring preload and thereby harden the suspension, turn the adjusting ring in direction (a). To decrease the spring preload and thereby soften the suspension, turn the adjusting ring in direction (b).

Rear torsion springs

EWS00751



The left and right spring preloads must be adjusted to the same setting. Uneven settings can cause poor handling and loss of stability.

To increase the spring preload and thereby harden the suspension, turn the adjuster in direction (a). To decrease the spring preload and thereby soften the suspension, turn the adjuster in direction (b).

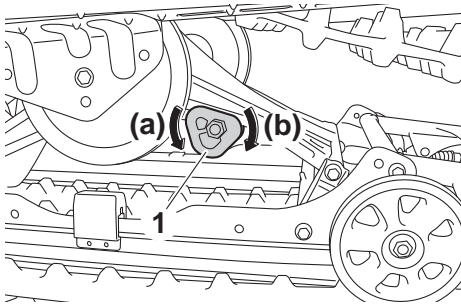

1. Spring preload adjuster

Spring preload setting:

Minimum (soft):

S

Standard:

S

Maximum (hard):

H

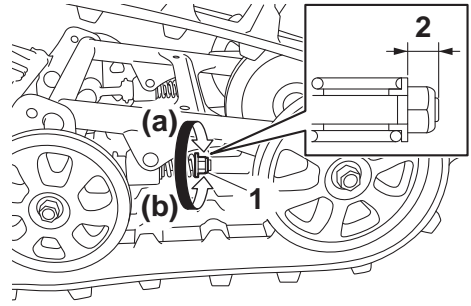

1. Spring preload adjusting nut

2. Distance A

TIP

The spring preload setting is determined by measuring distance A, shown in the illustration. The longer distance A is, the higher the spring preload; the shorter distance A is, the lower the spring preload.

ESU13114

Adjusting the spring preload of the sliding frame extension

EWS00751



WARNING

The left and right spring preloads must be adjusted to the same setting. Uneven settings can cause poor handling and loss of stability.

The spring preload of the sliding frame extension can be adjusted by turning the adjusting nuts.

To increase the spring preload, turn the adjusting nut in direction (a). To decrease the spring preload, turn the adjusting nut in direction (b).

Spring preload setting*:

Minimum (soft):

13 mm (0.51 in)

Standard:

13 mm (0.51 in)

Maximum (hard):

15 mm (0.59 in)

* Distance A changes 1.25 mm (0.05 in) with each full turn of the adjusting nut.

Pre-operation checks

ESU11072

Inspect your vehicle each time you use it to make sure the vehicle is in safe operating condition. Always follow the inspection and maintenance procedures and schedules described in the Owner's Manual.

EWS00192



Failure to inspect or maintain the vehicle properly increases the possibility of an accident or equipment damage. Do not operate the vehicle if you find any problem. If a problem cannot be corrected by the procedures provided in this manual, have the vehicle inspected by a Yamaha dealer.

ESU11082

Pre-operation check list

ITEM	CHECKS	PAGE
Fuel	<ul style="list-style-type: none">• Check fuel level.• Refuel if necessary.• Check fuel line for leakage.	26
Engine oil	<ul style="list-style-type: none">• Check oil level in engine.• If necessary, add recommended oil to specified level.• Check vehicle for oil leakage.	50
Coolant	<ul style="list-style-type: none">• Check coolant level.• Add if necessary.	55
V-belt	<ul style="list-style-type: none">• Check for wear and damage.• Replace if necessary.	56
Drive guard	<ul style="list-style-type: none">• Make sure the drive guard is installed securely.• Check the drive guard mounts for damage.	22
Brake	<ul style="list-style-type: none">• Check operation.• If soft or spongy, have Yamaha dealer bleed hydraulic system.• Check brake pads for wear.• Replace if necessary.• Check fluid level in master cylinder.• If necessary, add recommended brake fluid to specified level.• Check hydraulic system for leakage.	60
Air filter	<ul style="list-style-type: none">• Check that there is no snow under the air filter element.• If necessary, brush off the snow.	49
Louvers	<ul style="list-style-type: none">• Check condition.• Remove snow if necessary.	23
Tool kit and recommended equipment	<ul style="list-style-type: none">• Check for proper placement.	45, 45
Shroud and covers	<ul style="list-style-type: none">• Make sure that the shroud and covers are securely fastened.	45

Pre-operation checks

ITEM	CHECKS	PAGE
Skis and ski runners	<ul style="list-style-type: none">• Check for wear and damage.• If necessary, have Yamaha dealer replace skis or ski runners.	63
Drive track	<ul style="list-style-type: none">• Check the deflection.• Adjust if necessary.• Check for wear and damage.• If necessary, have a Yamaha dealer replace track.	66
Slide runners	<ul style="list-style-type: none">• Check for wear and damage.• If necessary, have Yamaha dealer replace slide runners.	66
Steering	<ul style="list-style-type: none">• Check for excessive free play.	65
Strap	<ul style="list-style-type: none">• Check for damage.• Replace if necessary.	38
Lights, signals and switches	<ul style="list-style-type: none">• Check operation.• Correct if necessary.	19, 19, 70, 71
Throttle lever	<ul style="list-style-type: none">• Make sure that operation is smooth and spring back to its original position when released.	13
Throttle override system (T.O.R.S.)	<ul style="list-style-type: none">• Check the T.O.R.S. for proper operation.• If system is not functioning properly, have Yamaha dealer check vehicle.	48

Operation

ESU13503

Read the Owner's Manual carefully to become familiar with all controls. If there is a control or function you do not understand, ask your Yamaha dealer.

EWS00204

WARNING

Failure to familiarize yourself with the controls can lead to loss of control, which could cause an accident or injury.

ESU13481

TIP

This model is equipped with an engine overheating prevention system, which prevents overheating when the engine is idling. When the engine has been idling for 3 minutes or longer and the coolant temperature has risen above 100 °C (212 °F), the engine automatically stops to prevent overheating. The engine can be started after it stops.

ESU11295

Starting the engine

1. Apply the parking brake.

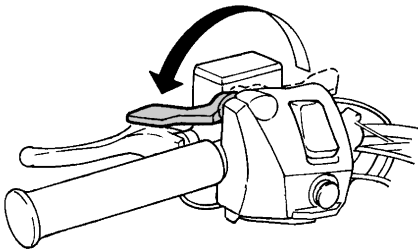

2. Be sure the engine stop switch is in the run position. The starter motor cannot be operated when the engine stop switch is in the off position.

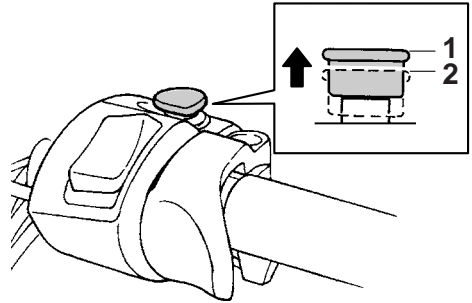

1. Run position
2. Off position
3. Fully open the starter (choke) lever.

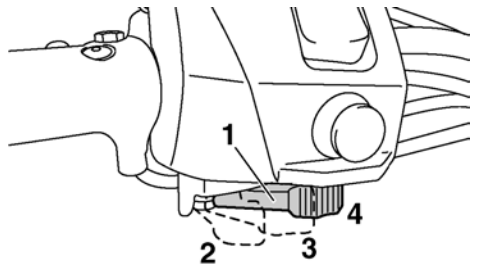

1. Starter (choke) lever
2. Fully open position (cold engine starting)
3. Half-open position (warming engine up)
4. Closed position (warm engine starting)

TIP

The starter (choke) lever is not required when the engine is warm. Move the starter (choke) lever to the closed position.

4. Turn the main switch to the start position and release it when the engine starts.

NOTICE: Release the switch immediately after the engine starts. If the engine fails to start, release the switch, wait a few seconds, then try again. Each attempt should be as short as possible to preserve the battery. Do not crank the engine more than 10 seconds on any one attempt. [ECS00332]

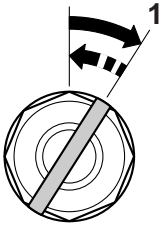

1. Start
5. Warm up the engine, and then close the starter (choke) lever when the engine runs smoothly.
6. Be sure the low coolant temperature indicator light has gone out before operation. (See page 15 for detailed information about the indicator light.)

ESU11311

Break-in

There is never a more important period in the life of your engine than the period between 0 and 500 km (300 mi). For this reason, you should read the following material carefully. Since the engine is brand new, do not put an excessive load on it for the first 500 km (300 mi). The various parts in the engine wear and polish themselves to the correct operating clearances. During this period, prolonged full-throttle operation or any condition that might result in engine overheating must be avoided.

Operating your snowmobile for the first time

Start the engine and let it idle for 15 minutes.

0–160 km (0–100 mi)

Avoid prolonged operation above 6000 r/min.

160–500 km (100–300 mi)

Avoid prolonged operation above 8000 r/min.

500 km (300 mi) and beyond

The snowmobile can now be operated normally.

ECS00341

NOTICE

- After 800 km (500 mi) of operation, the engine oil must be changed and the oil filter cartridge replaced.
- If any engine trouble should occur during the engine break-in period, immediately have a Yamaha dealer check the snowmobile.

ESU12626

Riding your snowmobile

Getting to know your snowmobile

EWS00212

WARNING

To avoid severe injury or death:

- Keep both hands on the handlebar during operation.
- Never put your feet outside the running boards.
- Avoid higher speeds or more difficult maneuvers until you have become thoroughly familiar with your snowmobile and all of its controls.

A snowmobile is a rider active vehicle, and your riding position and your balance are the two basic factors of maneuvering your snowmobile.

Riding your snowmobile requires skills acquired through practice over a period of time. Take the time to learn the basic techniques well before attempting more difficult maneuvers.

Riding your new snowmobile can be a very enjoyable activity, providing you with hours of pleasure. However, it is essential to familiarize yourself with the operation of the snowmobile to achieve the skill necessary to enjoy riding safely. Before operating the snowmobile, read this Owner's Manual completely and understand the operation of the controls.

Operation

Pay particular attention to the safety information on page 9.

Please read all warning and notice labels on your snowmobile.

Learning to ride your snowmobile

Before you ride, always perform the pre-operation checks listed on page 30. The short time spent checking the condition of the snowmobile will be rewarded with added safety and a more reliable snowmobile. Always wear the proper clothing for both warmth and to help protect you from injury if an accident occurs.

Become familiar with operating your snowmobile at low speeds, even if you are an experienced rider. Do not attempt to operate at maximum performance until you are totally familiar with the snowmobile's handling and performance characteristics.

The beginning operator should select a large flat area to become familiar with the snowmobile. Make sure that this area is free of obstacles and other traffic. You should practice control of the throttle and brake, and master turning techniques in this area before trying more difficult terrain.

Set the parking brake and follow the instructions on page 32 to start the engine. Once the engine has warmed up, you are ready to begin riding your snowmobile.

To start out and accelerate

1. With the engine idling, release the parking brake.
2. Apply the throttle slowly and smoothly. The V-belt clutch will engage and you will start to accelerate. **WARNING! Do not allow anyone to stand behind the snowmobile when starting the engine. A broken track, track fittings, or debris thrown by the track could be dangerous to bystanders.** [EWS00691]

Braking

EWS00221

WARNING

- Many surfaces such as ice and hard-packed snow require much longer stopping distances. Be alert, plan ahead, and begin decelerating early.
- Improper use of the brake can cause the drive track to lose traction, reduce control, and increase the possibility of an accident.

When slowing down or stopping, release the throttle and apply the brake gently—not suddenly.

Turning

For most snow surfaces, “body English” is the key to turning.

As you approach a curve, slow down and begin to turn the handlebar in the desired direction. As you do so, put your weight on the running board to the inside of the turn and lean your upper body into the turn.

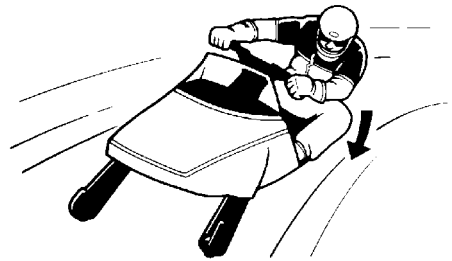

This procedure should be practiced at low speeds many times, in a large flat area with no obstacles. Once you have learned this technique, you should be able to perform it at higher speeds or in tighter curves. Lean more as the turn gets sharper or is made at higher speeds.

Improper riding techniques such as abrupt throttle changes, excessive braking, incorrect body movements, or too much speed for the sharpness of the turn may cause the snowmobile to tip.

If your snowmobile begins to tip while turning, lean more into the turn to regain balance. If necessary, gradually let off on the throttle or steer to the outside of the turn.

Remember:

Avoid higher speeds until you are thoroughly familiar with the operation of your snowmobile.

Riding uphill

EWS00232

WARNING

Operation on slopes can lead to loss of control if proper techniques are not used. Follow these instructions to reduce your risk of an accident. Do not try steeper or more difficult inclines until you have developed your skill on gentle slopes.

You should practice first on gentle slopes. Try more difficult climbs only after you have developed your skill. As you approach a hill, accelerate before you start the climb, and then reduce the throttle to prevent track slippage. It is also important to keep your weight on the uphill side at all times. On climbs straight up the hill, this can be accomplished by leaning forward and, on steeper inclines, standing on the running boards and leaning forward over the handlebar. (Also see “Traversing a slope”.)

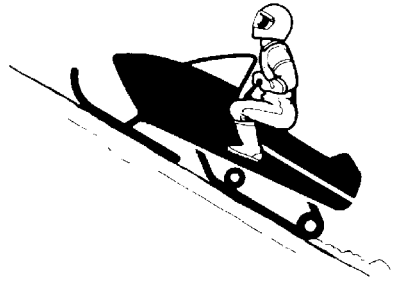

Slow down as you reach the crest of the hill, and be prepared to react to obstacles, sharp drops, or other vehicles or people which may be on the other side. If you are unable to continue up a hill, do not spin the track. Stop the engine and set the parking brake. Then pull the rear of the snowmobile around to point the snowmobile back down the hill. When the snowmobile is pointed downhill, mount your snowmobile from the uphill side. Restart the engine, release the parking brake, and descend the hill.

Riding downhill

EWS00241

WARNING

Use extra caution when applying the brake during a descent. Excessive braking will cause the drive track to lock, causing a loss of control.

When riding downhill, keep speed to a minimum. It is important to apply just enough throttle to keep the clutch engaged while descending the hill. This will allow you to use engine compression to help slow the snowmobile, and to keep the snowmobile from rolling freely down the hill. Also apply the brake frequently, with light pressure.

Operation

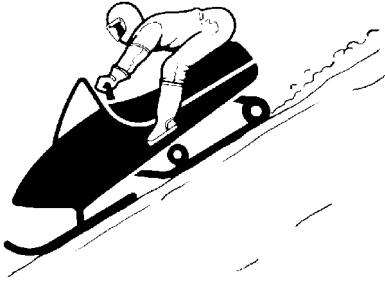

Traversing a slope

EWS00252

WARNING

Driving across the face of a slope (“side-hilling”) can lead to overturn or loss of control if proper techniques are not used. Follow these instructions to reduce your risk of an accident. Do not try steeper or more difficult inclines until you have developed your skill on gentle slopes.

Traversing a slope requires you to properly position your weight to maintain proper balance. As you travel across the slope, lean your body to position your weight towards the uphill side. A recommended riding position is to kneel with the knee of your downhill leg on the seat and the foot of your uphill leg on the running board. This position will make it easier for you to shift your body weight as needed.

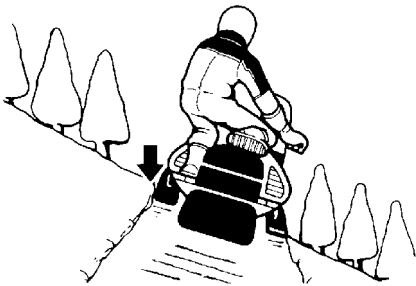

Snow and ice are slippery, so be prepared for the possibility that your snowmobile could begin to slip sideways on the slope. If this happens, steer in the direction of the slide if there are no obstacles in your path. As you regain proper balance, gradually steer again in the direction you wish to travel.

If your snowmobile starts to tip, steer down the hill to regain balance. **WARNING! If you are unable to maintain correct balance, and your snowmobile is going to tip over, dismount your snowmobile immediately on the uphill side to avoid being hit or caught under the snowmobile as it tips over.** [EWS00262]

Ice or icy surface

EWS00271

WARNING

When you have to operate on ice or icy surfaces, drive slowly and cautiously. Avoid accelerating, turning, and braking rapidly. Steering is minimal and uncontrolled spins are an ever-present danger.

Operating on ice or icy surfaces can be very dangerous. Traction for turning, stopping, and starting is much less than that on snow.

Hard-packed snow

It can be more difficult to negotiate on hard-packed snow as both the skis and drive track do not have as much traction as when the snowmobile is operated on fresh snow. Avoid rapid acceleration, turning, and braking.

Operation on surfaces other than snow or ice

Operation of your snowmobile on surfaces other than snow or ice should be avoided. Operation under such conditions will damage or result in rapid wear of the ski runners, drive

track, slide runners, and drive sprockets. Operation of the snowmobile on the following surfaces should be avoided at all times:

- Dirt
- Sand
- Rocks
- Grass
- Bare pavement

Other surfaces that should be avoided for the sake of drive track and slide runner life are:

- Glare ice surfaces
- Snow mixed with a lot of dirt and sand

All of the above surfaces have one thing in common in regard to drive track and slide runners: little or no lubricating ability. Drive track and all slide rail systems require lubrication (snow or water) between the slide runners and the slide metal. In the absence of lubrication, the slide runners will rapidly wear and in severe cases, literally melt away, and the drive track will be subject to damage or failure.

Also traction aids such as studs, cleats, etc., may cause further track damage or failure.

EWS00281

WARNING

Drive track damage or failure could result in loss of braking ability and snowmobile control, which could cause an accident.

- **Always check the drive track for damage or maladjustment before operating the snowmobile.**
- **Do not operate the snowmobile if you find damage to the drive track.**

ECS00351

NOTICE

Ride on fresh snow frequently. Operating on ice or hard-packed snow will rapidly wear the slide runners.

ESU11351

Maximizing drive track life

Recommendations

Track tension

During initial break-in, the new drive track will tend to stretch quickly as the track settles. Be sure to correct the track tension and alignment frequently. (See page 66 for adjustment procedures.) A loose track can slip (ratchet), derail or catch on suspension parts causing severe damage. Do not overtighten the drive track, otherwise it may increase the friction between the track and the slide runners, resulting in the rapid wear of both components. Also, this may put an excessive load on the suspension components, resulting in component failure.

Marginal snow

The drive track and the slide runners are lubricated and cooled by snow and water. To prevent the drive track and slide runners from overheating, avoid sustained high-speed usage in areas such as icy trails, frozen lakes and rivers that have minimal snow coverage. An overheated track will be weakened internally, which may cause failure or damage.

Off-trail riding

Avoid off-trail riding until there is sufficient snow coverage. It generally takes several feet of snow to provide a good overall base to properly cover debris, such as rocks, logs, etc. If snow coverage is not sufficient, stay on trails to avoid impact damage to the drive track.

Studded track

In general, track life will be shortened when studs are installed. Drilling stud holes into the drive track will cut the internal fibers, which weakens the track. Avoid spinning the drive track. Studs may catch on an object and pull out of the track, leaving tears and damage

Operation

around the already weakened area. To minimize possible damage, consult your stud manufacturer for installation and stud pattern recommendations.

Yamaha does not recommend track stud-ding.

ESU11361

Strap

The strap should be used only by experienced operators to assist them when traverse (side-hill) riding.

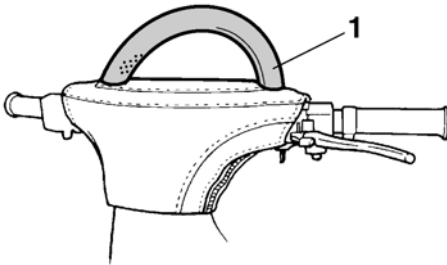

1. Strap

EWS00291

WARNING

Improper use of the strap on the handlebar can result in severe injury or death.

- Use the strap only as an operator grip point when needed to shift weight uphill to maintain balance during traverse (side-hill) riding. Only experienced operators should traverse slopes steep enough to require strap use.
- Keep the right hand on the right handlebar grip for steering, and grip the strap with the left hand to shift weight uphill for balance during traverse riding.
- Ride cautiously while using the strap. Do not accelerate or decelerate abruptly while holding onto the strap.
- Do not use the strap to lift the snowmobile.

- Do not use the strap as a mounting point for cargo or accessories.

ESU12577

Driving

EWS00301

WARNING

Be sure to read the “SAFETY INFORMATION” section on page 9 and the “Riding your snowmobile” section on page 33 carefully before operating the snowmobile.

EWS00632

WARNING

- Make sure that the throttle lever is fully released and the snowmobile is at a full stop before shifting.
- Be sure to turn the shift lever to “D”, “R” or “L” until it stops completely and only while the engine is idling.
- Do not exceed 80 km/h (50 mi/h) when the shift lever is set to the “L” position.
- Make sure that the area behind the snowmobile is clear before reversing. Watch behind.
- Reduce speed and avoid sharp turning when operating the snowmobile in reverse.

TIP

Make sure that the engine is warmed up before riding.

1. While the engine is idling, select the desired operating position (“D”, “R”, or “L”) by pulling the shift lever out, turning it to the position, and then releasing it. **NOTICE:** Do not shift from forward to reverse or from reverse to forward while the snowmobile is moving, as the drive train could be damaged.

[ECS00743]

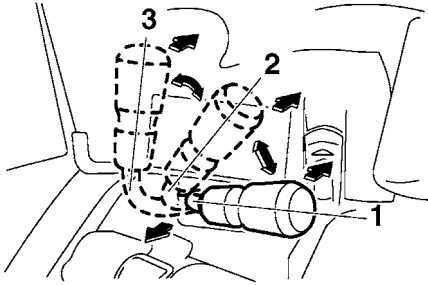

1. "D" Drive (forward)
2. "R" Reverse
3. "L" Low (forward)

TIP

The reverse buzzer beeps while the transmission is in reverse.

2. Release the parking brake by moving the parking brake lever to the right.

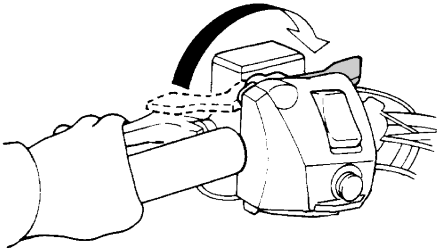

3. Squeeze the throttle lever slowly to start out.
4. Turn the handlebar in the desired direction.
5. Squeeze the brake lever to stop the snowmobile.
6. Apply the parking brake by moving the parking brake lever to the left.

ESU11412

Stopping the engine

- Turn the main switch to the off position to stop the engine.

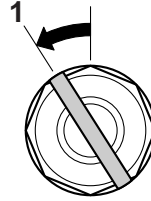

1. Off

- Push down the engine stop switch to stop the engine in an emergency.

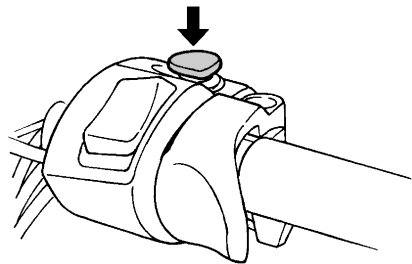

ESU11421

Transporting

When transporting your snowmobile on a trailer or in a truck, observe the following recommendations to help protect it from damage:

- Make sure that the fuel level in the fuel tank is lower than the bottom of the carburetors. Otherwise, the vibration and bumps from the road surface could make it possible for fuel to flow through the carburetors into the cylinders. This can result in "hydrostatic lock," a condition where the engine cannot rotate because of fuel accumulated in the engine. Severe engine damage can result from hydrostatic lock. When possible, the fuel tank should be empty during transportation, especially if the trip takes longer than 30 minutes.

Operation

- If transporting the snowmobile in an open trailer or truck, put a tight fitting cover on the snowmobile. A cover specifically designed for your snowmobile is best. This will help keep foreign objects out of the cooling vents in the shroud, and also help protect the snowmobile against damage from debris on the road.
- If transporting the snowmobile in an open trailer or truck in areas where road salt is used, coat metal suspension surfaces lightly with oil or another protectant. This will help protect against corrosion. Be sure to clean the snowmobile when you get to your destination to remove any corrosive salts.

Periodic maintenance and adjustment

ESU11453

Periodic inspection, adjustment, and lubrication will keep your snowmobile in the safest and most efficient condition possible. Safety is an obligation of the vehicle owner/operator. The most important points of vehicle inspection, adjustment, and lubrication are explained on the following pages.

EWS00342

WARNING

Failure to properly maintain the snowmobile or performing maintenance activities incorrectly may increase your risk of injury or death during service or while using the snowmobile. If you are not familiar with snowmobile service, have a Yamaha dealer perform service.

EWS00701

WARNING

Turn off the engine when performing maintenance unless otherwise specified.

- **A running engine has moving parts that can catch on body parts or clothing, and electrical parts that can cause shocks or fires.**
 - **Running the engine while servicing can lead to eye injury, burns, fire, or carbon monoxide poisoning—possibly leading to death. See page 9 for more information about carbon monoxide.**
-

EWS00791

WARNING

Brake discs, calipers, and linings can become very hot during use. To avoid possible burns, let brake components cool before touching them.

Maintenance, replacement, or repair of the emission control devices and systems may be performed by any repair establishment or individual that is certified (if applicable).

Proper periodic maintenance of your snowmobile is important in order to enjoy long, pleasurable use. Especially important are the maintenance services related to emission control. These controls not only function to ensure cleaner air, but are also vital to proper engine operation and maximum performance. In the following periodic maintenance charts, the services related to emission control are grouped separately. These services require specialized data, knowledge, and equipment. Yamaha dealers are trained and equipped to perform these particular services.

Periodic maintenance and adjustment

ESU11462

Periodic maintenance chart for the emission control system

Items marked with an asterisk should be performed by a Yamaha dealer as they require special tools, data and technical skills.

	ITEM	REMARKS	INITIAL	EVERY	PAGE
			1 month or 800 km (500 mi) (40 hr)	Seasonally or 4000 km (2500 mi) (200 hr)	
	Spark plugs	<ul style="list-style-type: none"> • Check condition. • Adjust gap and clean. • Replace if necessary. 		●	46
*	Valve clearance	<ul style="list-style-type: none"> • Check and adjust valve clearance when engine is cold. 	Every 40000 km (25000 mi)		50
*	Crankcase breather system	<ul style="list-style-type: none"> • Check breather hose for cracks or damage. • Replace if necessary. 		●	—
*	Fuel filter	<ul style="list-style-type: none"> • Check condition. • Replace if necessary. 		●	—
*	Fuel line	<ul style="list-style-type: none"> • Check fuel hose for cracks or damage. • Replace if necessary. 		●	—
*	Idle speed	<ul style="list-style-type: none"> • Check and adjust idle speed. 	●	●	47
*	Carburetors	<ul style="list-style-type: none"> • Adjust synchronization. 	●	●	—
		<ul style="list-style-type: none"> • Adjust the jets. 	Whenever operating condition (elevation/temperature) is changed.		50
*	Exhaust system	<ul style="list-style-type: none"> • Check for leakage. • Tighten or replace gasket if necessary. 		●	—

Periodic maintenance and adjustment

ESU11566

General maintenance and lubrication chart

	ITEM	REMARKS	INITIAL	EVERY	PAGE
			1 month or 800 km (500 mi) (40 hr)	Seasonally or 4000 km (2500 mi) (200 hr)	
	Engine oil	<ul style="list-style-type: none"> Change (warm engine before draining). 	●	●	50
*	Engine oil filter cartridge	<ul style="list-style-type: none"> Replace. 	●	Every 20000 km (12000 mi)	50
*	Cooling system	<ul style="list-style-type: none"> Check coolant level. Bleed the cooling system if necessary. 		●	55
*	Primary and secondary clutches	<ul style="list-style-type: none"> Check engagement and shift speed. Adjust if necessary. 		●	—
			Whenever operating elevation is changed.		—
		<ul style="list-style-type: none"> Inspect sheaves for wear and damage. Inspect weights/rollers and bushings for wear for primary. Inspect ramp shoes/bushings for wear for secondary. Replace if necessary. 		●	—
		<ul style="list-style-type: none"> Lubricate with specified grease. 		●	—
*	Drive chain	<ul style="list-style-type: none"> Check chain slack. Adjust if necessary. 	Initial at 500 km (300 mi) and every 800 km (500 mi) thereafter.		59
*	Drive chain oil	<ul style="list-style-type: none"> Check oil level. 	●	●	59
		<ul style="list-style-type: none"> Change. 		●	59
*	Shift lever	<ul style="list-style-type: none"> Lubricate with specified grease. 		●	—
*	Brake and parking brake	<ul style="list-style-type: none"> Adjust free play and/or replace pads if necessary. 		●	60
		<ul style="list-style-type: none"> Change brake fluid. 	See TIP following this chart.		60
	Control cables	<ul style="list-style-type: none"> Make sure that operation is smooth. Lubricate if necessary. 		●	69
*	Disc brake installation	<ul style="list-style-type: none"> Check for slight free play. Lubricate shaft with specified grease as required. 	Every 1600 km (1000 mi)		—
*	Extrovert drive sprocket	<ul style="list-style-type: none"> Check for wear and damage. Replace if necessary. 	●	●	63

Periodic maintenance and adjustment

	ITEM	REMARKS	INITIAL	EVERY	PAGE
			1 month or 800 km (500 mi) (40 hr)	Seasonally or 4000 km (2500 mi) (200 hr)	
*	Slide runners	<ul style="list-style-type: none"> • Check for wear and damage. • Replace if necessary. 		●	66
*	Skis and ski runners	<ul style="list-style-type: none"> • Check for wear and damage. • Replace if necessary. 		●	63
*	Steering system	<ul style="list-style-type: none"> • Check toe-out. • Adjust if necessary. 		●	65
*	Steering bearings	<ul style="list-style-type: none"> • Check bearing assemblies for looseness. • Lubricate with specified grease. 		●	—
*	Skis and front shock absorbers	<ul style="list-style-type: none"> • Lubricate with specified grease. 		●	69
*	Suspension component	<ul style="list-style-type: none"> • Lubricate with specified grease. 		●	69
*	Drive track	<ul style="list-style-type: none"> • Check the deflection. • Adjust if necessary. 	Initial at 500 km (300 mi) and every 800 km (500 mi) thereafter.		66
	Fittings and fasteners	<ul style="list-style-type: none"> • Make sure that all nuts, bolts and screws are properly tightened. • Tighten if necessary. 	●	●	71
*	Battery	<ul style="list-style-type: none"> • Check condition. • Charge if necessary. 		●	71

TIP

Brake system:

- After disassembling the master cylinder or caliper cylinder, always change the brake fluid. Regularly check the brake fluid level and add fluid if necessary.
- Replace the oil seals of the master cylinder and caliper cylinder every two years.
- Replace the brake hose every four years, or if cracked or damaged.

Periodic maintenance and adjustment

ESU13471

Tool kit

The service information included in this manual and the tools provided in the owner's tool kit are intended to assist you in the performance of preventive maintenance and minor repairs. However, additional tools such as a torque wrench may be necessary to perform certain maintenance work correctly.

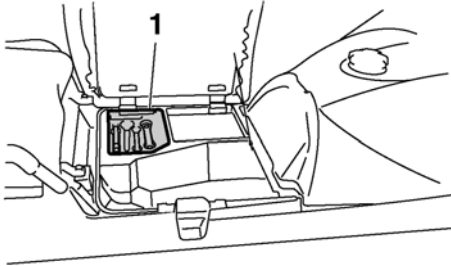

1. Tool kit

ECS00961

NOTICE

Before starting the engine, make sure that the tools are properly seated in their holder.

TIP

If you do not have a torque wrench available during a service operation requiring one, take your snowmobile to a Yamaha dealer to check the torque settings and adjust them if necessary.

ESU14231

Recommended equipment

It is good practice to carry the spare parts and other necessary equipment with you while riding the snowmobile so that minor repairs can be done if necessary. The following should be carried at all times:

- Flashlight
- Roll of plastic tape
- Steel wire
- Tow rope

- V-belt
- Light bulbs

When you start out for a long distance trip, extra fuel should be carried as well.

ESU13963

Opening and closing the shroud and removing and installing the right side cover

EWS00811

WARNING

Be sure the shroud and right side cover are secured before operation. A loose shroud or cover could move and cause loss of control.

Shroud

To open the shroud

Unhook the shroud latches, and then slowly raise the shroud forward until it stops.

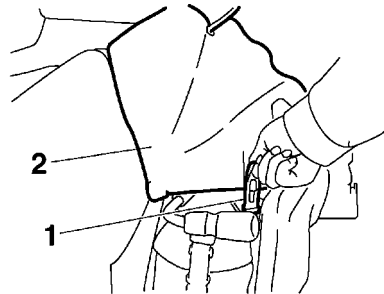

1. Shroud latch
2. Shroud

To close the shroud

Slowly lower the shroud to its original position, and then hook the shroud latches.

Right side cover

To remove the right side cover

1. Open the shroud. (See the above procedure.)
2. Remove the screws and bolts, and then remove the right side cover.

Periodic maintenance and adjustment

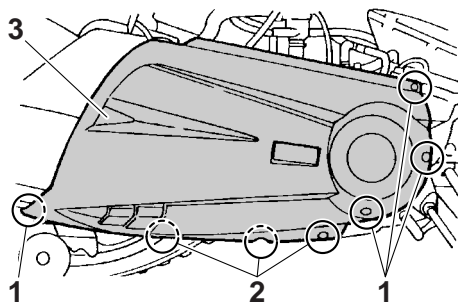

1. Screw
2. Bolt
3. Right side cover

To install the right side cover

1. Place the right side cover in the original position, and then tighten the bolts and screws.
2. Close the shroud.

ECS01041

NOTICE

- **Make sure that all cables, leads, and hoses are routed properly before closing the shroud and installing the right side cover.**
- **When installing the right side cover, be sure to tighten the bolts and screws securely.**

ESU11785

Checking the spark plugs

The spark plugs are important engine components and are easy to inspect. The condition of the spark plugs can indicate the condition of the engine.

Check the coloration on the white porcelain insulator around the center electrode. The ideal coloration at this point is a medium-to-light tan color for a snowmobile that is being ridden normally. If any spark plug shows a distinctly different color, there could be something wrong with the engine. For example, a very white center electrode porcelain color could indicate an intake track air leak or

carburetion problem for that cylinder. Do not attempt to diagnose such problems yourself. Instead, take the snowmobile to a Yamaha dealer for inspection and possible repairs.

You should periodically remove and inspect the spark plugs because heat and deposits will cause any spark plug to slowly break down and erode. Consult a Yamaha dealer before changing to a different type of spark plug.

Specified spark plug:
Manufacturer:
NGK
Model:
CR8E

EWS00711

WARNING

Be sure to use the specified spark plug and spark plug cap. Otherwise, the T.O.R.S. may not work properly.

Spark plugs are produced in several different thread lengths. The thread length or reach is the distance from the spark plug gasket seat to the end of the threaded portion. If the reach is too long, overheating and engine damage may result. If the reach is too short, spark plug fouling and poor performance may result. Also, if the reach is too short, carbon will form on the exposed threads resulting in combustion chamber hot spots and thread damage. Always use a spark plug with the specified reach.

Spark plug reach:
19.0 mm (0.75 in)

Periodic maintenance and adjustment

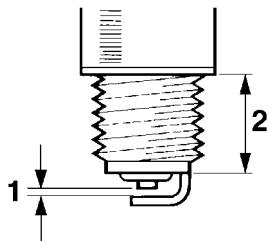

1. Spark plug gap
2. Spark plug reach

Before installing any spark plug, measure the spark plug gap with a wire thickness gauge and adjust to specification.

Spark plug gap:
0.7–0.8 mm (0.028–0.031 in)

When installing the spark plug, always clean the gasket surface. Wipe off any grime from the threads and tighten the spark plug to the specified torque.

Spark plug tightening torque:
13 Nm (1.3 m·kgf, 9.4 ft·lbf)

ECS00383

NOTICE

Make sure that the spark plug caps are securely installed. Otherwise the spark plug caps could be damaged due to engine vibration.

ESU11796

Adjusting the engine idling speed

1. Place the snowmobile on a level surface and apply the parking brake.
2. Start the engine and warm it up.

TIP

Refer to the “Starting the engine” section on page 32.

3. Open the shroud.
4. Turn the throttle stop screw in or out to adjust the engine idling speed.

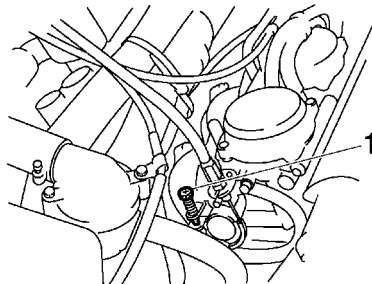

1. Throttle stop screw

Standard engine idling speed:
1300–1500 r/min

5. Close the shroud.

ESU11825

Adjusting the throttle lever free play

ECS00411

NOTICE

Be sure to adjust the engine idling speed first.

1. Place the snowmobile on a level surface and apply the parking brake.
2. Open the shroud.
3. Loosen the locknut.
4. Turn the adjusting bolt in or out until the specified throttle lever free play is obtained.

Periodic maintenance and adjustment

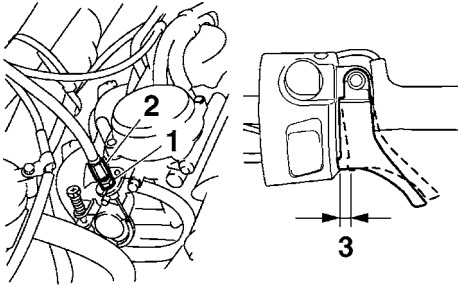

1. Locknut
2. Throttle lever free play adjusting bolt
3. Throttle lever free play

Throttle lever free play:
2.0–3.0 mm (0.08–0.12 in)

5. Tighten the locknut.
6. Close the shroud.

ESU11864

Checking the throttle override system (T.O.R.S.)

EWS00353

WARNING

When checking the T.O.R.S., take precautions to avoid snowmobile movement which could cause an accident:

- Make sure that the throttle lever moves smoothly with the engine off before checking the T.O.R.S.
- Make sure that the parking brake is applied.
- Do not rev the engine to the point that the clutch engages.

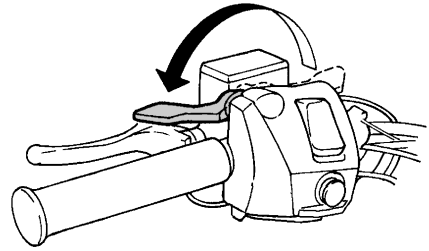

Check the T.O.R.S. for proper operation.

1. Start the engine.

TIP

Refer to the “Starting the engine” section on page 32.

2. Hold the pivot point of the throttle lever away from the throttle switch by putting your thumb (above) and forefinger (below) between the throttle lever pivot and the engine stop switch housing. While holding the pivot point as described above, squeeze the throttle lever gradually.

Periodic maintenance and adjustment

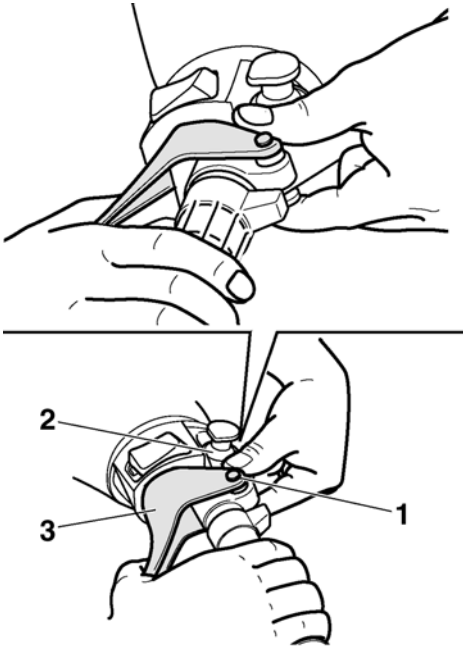

1. Throttle lever pivot
2. Engine stop switch housing
3. Throttle lever

The T.O.R.S. will be activated and the engine speed will be limited to less than the clutch engagement speed. (See page 81 for the clutch engagement speed.)

WARNING! If the engine speed does not decrease to less than the clutch engagement speed, stop the engine by turning the main switch to the off position and consult a Yamaha dealer. Operating the snowmobile with a malfunctioning T.O.R.S. could result in loss of control. [EWS00363]

ESU11876

Checking the air filter

Check that there is no snow under the air filter element frame after each ride. In addition, snow may need to be cleaned during a ride depending on the riding conditions.

1. Place the snowmobile on a level surface and apply the parking brake.
2. Open the shroud.
3. Remove the air filter case cover by unhooking the case fastener and the case cover fasteners.

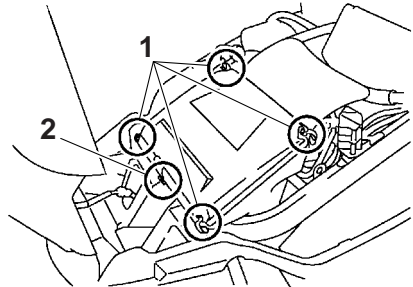

1. Air filter case cover fastener
2. Air filter case fastener
4. Lift up the air filter element frame and check the air filter element. If there is any snow on the air filter element, remove the element, brush off the snow, and then install the air filter element.

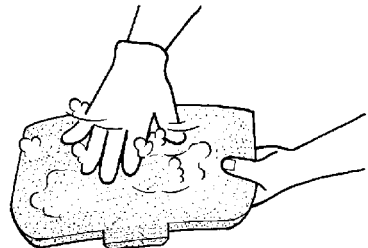
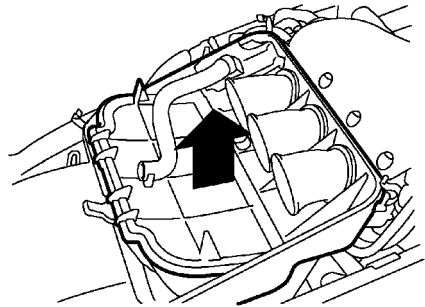

Periodic maintenance and adjustment

5. Place the air filter element frame in the original position.
6. Install the air filter case cover and attach the air filter case by hooking all the fasteners.
7. Close the shroud.

ESU11912

Carburetors

The carburetors are an important part of the engine and its emission control system, which require very sophisticated adjustment. Therefore, carburetor adjustments should be left to a Yamaha dealer, who has the necessary professional knowledge and experience.

ESU11942

High-altitude settings

Operating at high altitude reduces the performance of a gasoline engine about 3% for every 305 m (1000 ft) of elevation. This is because there is less air as altitude increases. Less air means less oxygen available for combustion.

Your snowmobile can be adjusted to overcome most of the problems found in high-altitude riding. Carburetor adjustments are the most important. Less air at high altitude makes the air/fuel ratio too rich, which can cause poor performance. Common problems are hard starting, bogging, and plug fouling. Proper carburetion adjustments will correct the air/fuel ratio. Be sure to have a Yamaha dealer make these adjustments.

Remember:

Less air at higher altitude means there is less horsepower available, even with proper carburetion. Expect acceleration and top speed to be reduced at higher altitudes.

To overcome operating with less power at high altitudes, your snowmobile may also require different settings for the drive chain gears and V-belt clutch to avoid poor performance and rapid wear. If you plan to operate your snowmobile at an altitude different from

the area where you bought it, be sure to consult a Yamaha dealer. The dealer can tell you if there are any changes necessary for the altitude where you plan to ride. **NOTICE: The drive chain gears and V-belt clutch should be adjusted when operating above a high altitude of 900 m (3000 ft). Consult a Yamaha dealer.** [ECS00432]

ESU11951

Valve clearance

The valve clearance changes with use, resulting in improper air-fuel mixture and/or engine noise. To prevent this from occurring, the valve clearance must be adjusted by a Yamaha dealer at the intervals specified in the periodic maintenance chart.

ESU11977

Engine oil and oil filter cartridge

The engine oil level should be checked before each use. In addition, the oil must be changed and the oil filter cartridge replaced at the intervals specified in the periodic maintenance and lubrication chart.

EWS00371

WARNING

Engine oil is extremely hot immediately after the engine is turned off. Coming into contact with or getting any engine oil on your clothes could result in burns.

ECS00483

NOTICE

- Do not run the engine with too much or not enough oil in the oil tank. Oil could spray out or the engine could be damaged.
- Be sure to change the engine oil after the first 800 km (500 mi) of operation, and every 4000 km (2500 mi) thereafter or at the start of a new season, otherwise the engine will wear quickly.

Periodic maintenance and adjustment

- The oil filter cartridge should be replaced after the first 800 km (500 mi) of operation, and every 20000 km (12000 mi) of operation thereafter.

To check the engine oil level

1. Place the snowmobile on a level surface and apply the parking brake.

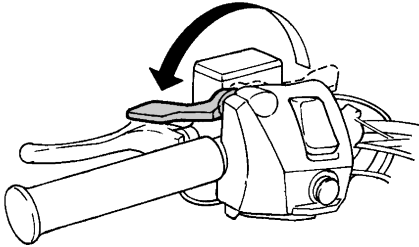

2. Start the engine, warm it up for 10–15 minutes, and then turn it off.

TIP

- The engine can also be warmed up by operating the snowmobile for 10–15 minutes.
- After operating the snowmobile, allow the engine to idle for at least 10 seconds before turning it off.

3. Open the shroud.
4. Disconnect the oil level gauge coupler.
NOTICE: Disconnect the oil level gauge coupler before removing the oil filler cap, otherwise the cable could twist and break. [ECS00453]

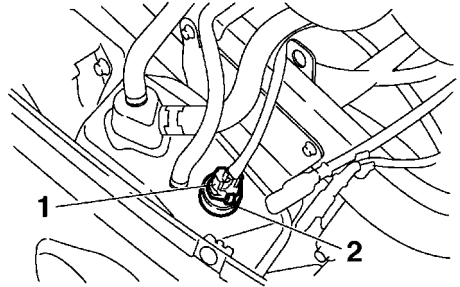

1. Oil level gauge coupler
 2. Oil filler cap
5. Remove the oil filler cap, wipe the dipstick clean, insert it back into the oil filler hole (without screwing it in), and then remove it again to check the oil level.

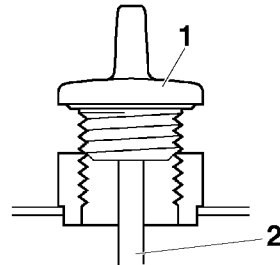

1. Oil filler cap
2. Dipstick

TIP

The engine oil should be between the “H” and “L” level marks on the dipstick.

Periodic maintenance and adjustment

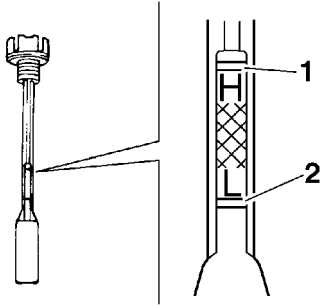

1. "H" level mark
2. "L" level mark

6. If the engine oil is below the "L" level mark, add sufficient oil of the recommended type to raise it to the "H" level mark. (See page 81 for the recommended oil.) **NOTICE: When adding the engine oil, be careful not to fill above the "H" level mark on the dipstick. Use only the recommended oil. (See page 81.) Make sure that no foreign material enters the engine oil tank.** [ECS00463]
7. Insert the dipstick into the oil filler hole, and then tighten the oil filler cap.
8. Connect the oil level gauge coupler.
9. Close the shroud.

To change the engine oil (with or without oil filter cartridge replacement)

1. Place the snowmobile on a level surface and apply the parking brake.
2. Start the engine, warm it up for several minutes, and then turn it off.
3. Open the shroud.
4. Remove the right side cover and the bottom panel.

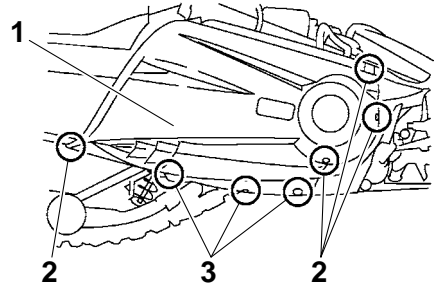

1. Right side cover
2. Screw
3. Bolt

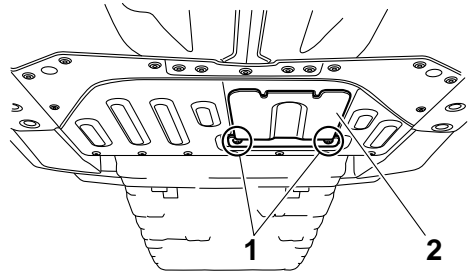

1. Bolt
2. Bottom panel
5. Place an oil pan under the oil tank to collect the used oil.
6. Disconnect the oil level gauge coupler.

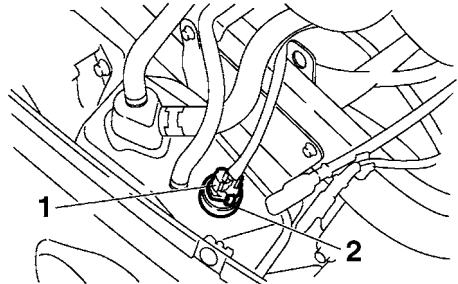

1. Oil level gauge coupler
2. Oil filler cap

Periodic maintenance and adjustment

7. Remove the oil filler cap and cylinder head cap, and then remove the engine oil drain bolt and its gasket to drain the oil from the oil tank.

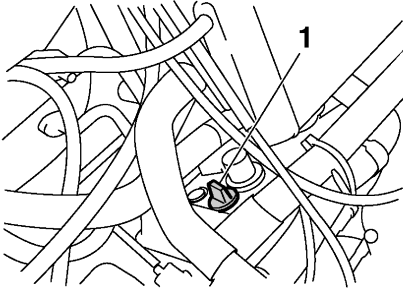

1. Cylinder head cap

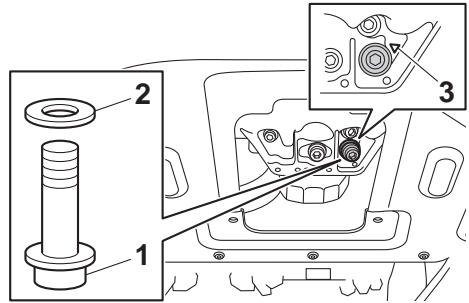

1. Engine oil drain bolt (crankcase)
2. Gasket
3. “▽” mark

TIP

- A “▽” mark is stamped on the crankcase near the engine oil drain bolt.
- Dispose of used oil according to local regulations.
- Skip steps 10–12 if the oil filter cartridge is not being replaced.

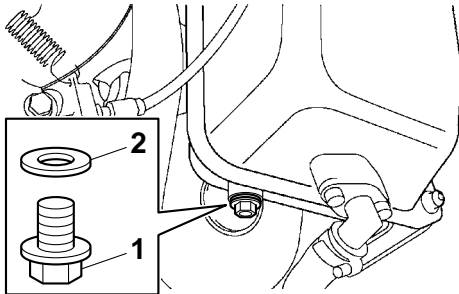

1. Engine oil drain bolt (oil tank)
2. Gasket

8. Place an oil pan under the engine to collect the used oil.
9. Remove the engine oil drain bolt and its gasket to drain the oil from the crankcase.

10. Remove the oil filter cartridge with an oil filter wrench.

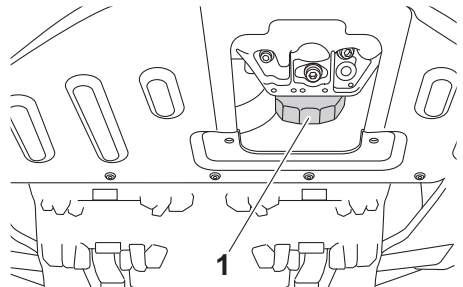

1. Oil filter cartridge

TIP

An oil filter wrench is available at a Yamaha dealer.

11. Apply a thin coat of engine oil to the O-ring of the new oil filter cartridge.

Periodic maintenance and adjustment

12. Install the new oil filter cartridge with an oil filter wrench, and then tighten it to the specified torque.

Tightening torque:
Oil filter cartridge:
17 Nm (1.7 m·kgf, 12 ft·lbf)

13. Install the engine oil drain bolts and their new gasket, and then tighten the bolts to the specified torques.

Tightening torques:
Engine oil drain bolt (crankcase):
10 Nm (1.0 m·kgf, 7.2 ft·lbf)
Engine oil drain bolt (oil tank):
16 Nm (1.6 m·kgf, 12 ft·lbf)

14. Add 2.0 L (2.11 US qt, 1.76 Imp.qt) of the recommended engine oil to the oil tank, and then install and tighten the oil filler cap and the cylinder head cap.
15. Start the engine, warm it up for several minutes, and then turn it off.
16. Remove the oil filler cap, and then add sufficient oil of the recommended type to raise it to the "H" level mark on the dipstick. (See above for the checking procedure.) **NOTICE: When adding the engine oil, be careful not to fill above the "H" level mark on the dipstick. Use only the recommended oil. (See page 81.) Make sure that no foreign material enters the engine oil tank.** [ECS00463]

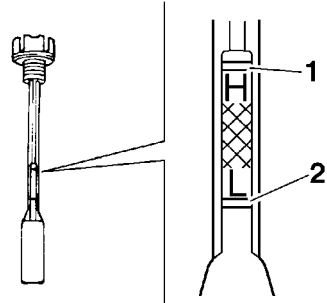

1. "H" level mark
2. "L" level mark

Recommended engine oil:
See page 81.
Oil quantity:
With oil filter cartridge replacement:
3.0 L (3.17 US qt, 2.64 Imp.qt)
Without oil filter cartridge replacement:
2.8 L (2.96 US qt, 2.46 Imp.qt)
Total amount:
3.7 L (3.91 US qt, 3.26 Imp.qt)

17. Install and tighten the oil filler cap.
18. Start the engine, and then let it idle for several minutes while checking it for oil leakage. If oil is leaking, immediately turn the engine off and make sure that the engine oil drain bolt, oil tank drain bolt, cylinder head cap, and the oil filler cap are installed correctly.
19. Turn the engine off, and then connect the oil level gauge coupler. **NOTICE: If oil is leaking or the oil level warning indicator comes on when the engine is running, immediately turn the engine off and have a Yamaha dealer check the snowmobile. Continuing to operate the engine under such conditions could cause severe engine damage.**

[ECS00472]

20. Install the bottom panel and the right side cover, and then close the shroud.

Periodic maintenance and adjustment

ESU12026

Cooling system

The coolant level should be checked before each ride. In addition, the cooling system must be bled at the intervals specified in the periodic maintenance and lubrication chart.

EWS00391

WARNING

Do not remove the radiator cap when the engine is hot. Scalding hot fluid and steam may be blown out under pressure, which could cause serious injury.

When the engine has cooled, place a thick rag or towel over the radiator cap, and slowly rotate the cap counterclockwise to the detent. This procedure allows any residual pressure to escape. When the hissing sound has stopped, press down on the cap while turning counterclockwise and remove it.

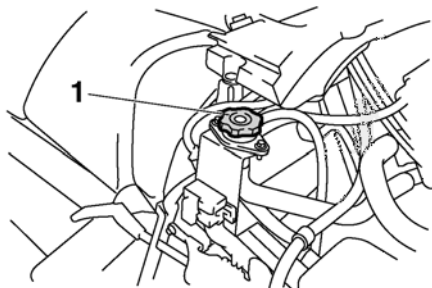

1. Radiator cap

To check the coolant level

1. Place the snowmobile on a level surface and apply the parking brake.
2. Open the shroud.
3. Check the coolant level in the coolant reservoir when the engine is cold. If the coolant level is below the "LOW" mark, remove the coolant reservoir cap and add coolant until it reaches the "FULL" mark. (See the following section "Replenishing the coolant" for more details.)

NOTICE: If coolant is not available, use distilled water or soft tap water instead. Do not use hard water or salt water since it is harmful to the engine. If water has been used instead of coolant, replace it with coolant as soon as possible, otherwise the cooling system will not be protected against frost and corrosion. If water has been added to the coolant, have a Yamaha dealer check the antifreeze content of the coolant as soon as possible, otherwise the effectiveness of the coolant will be reduced. [ECS00493]

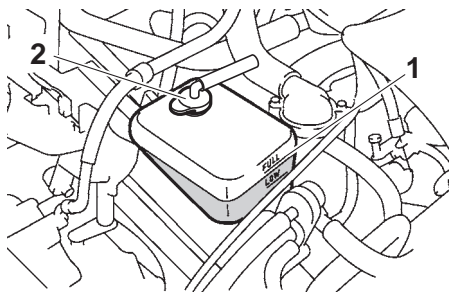

1. "FULL" mark
2. Coolant reservoir cap
4. Close the shroud.

Bleeding the cooling system

The cooling system must be bled if the coolant reservoir becomes empty, if air can be seen in the cooling system, or if there is a cooling system leak. Consult a Yamaha dealer.

ECS00501

NOTICE

Operating the engine with an improperly bled cooling system can cause overheating and severe engine damage.

Replenishing the coolant

1. Place the snowmobile on a level surface and apply the parking brake.

Periodic maintenance and adjustment

2. Open the shroud.
3. Remove the coolant reservoir cap and add coolant until it reaches the “FULL” mark.

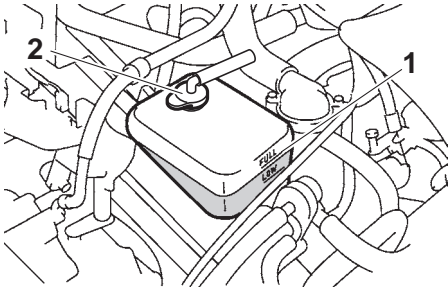

1. “FULL” mark
2. Coolant reservoir cap

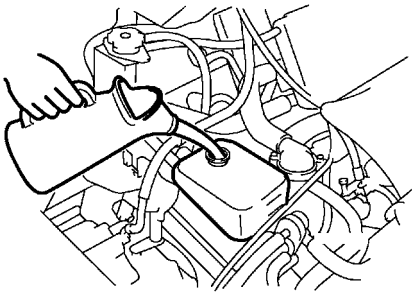

Recommended antifreeze:
High-quality ethylene glycol anti-
freeze containing corrosion inhibitors
Antifreeze and water mixing ratio:
3:2
Total amount:
4.70 L (4.97 US qt, 4.14 Imp.qt)

4. Start the engine and add coolant until the coolant level stabilizes, and then stop the engine.
5. Fill the coolant reservoir with coolant until it reaches the “FULL” mark.
6. Install the coolant reservoir cap.
7. Check for any coolant leakage.

TIP

If you find any leaks, consult a Yamaha dealer.

8. Close the shroud.

ESU12057

V-belt

EWS00403

⚠ WARNING

- Coming in contact with the rotating V-belt or clutch parts can cause severe injury or death. Never run the engine with the drive guard removed.
- Make sure that the drive guard is installed securely before operating the snowmobile to protect against severe injury or death from a broken V-belt or other part should it come off the snowmobile while it is in operation.

ECS00831

NOTICE

Never run the engine with the V-belt removed. Clutch components can be damaged.

The V-belt should be checked before each ride.

To check the V-belt

1. Open the shroud and remove the drive guard.
2. Check the V-belt for wear and damage. Replace if necessary.

Periodic maintenance and adjustment

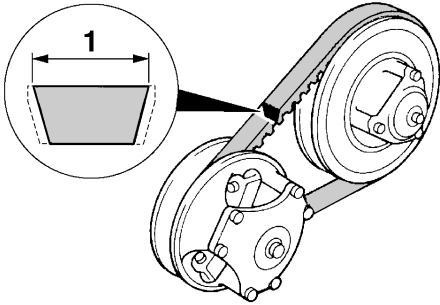

1. V-belt wear limit

New V-belt width:
34.5 mm (1.36 in)
V-belt wear limit width:
32.5 mm (1.28 in)

3. Install the drive guard and close the shroud.

To replace and adjust the V-belt

EWS00412

WARNING

When installing a new V-belt, make sure that it is positioned properly. Otherwise, the V-belt clutch engagement speed will be changed and the snowmobile may move unexpectedly when the engine is started, which could cause an accident.

ECS00512

NOTICE

As the V-belt wears, the position of the V-belt will change. If the V-belt position is out of specification, it must be adjusted to ensure proper clutch performance. Have a Yamaha dealer make this adjustment.

1. Place the snowmobile on a level surface and apply the parking brake.
2. Open the shroud and remove the drive guard.

3. Rotate the secondary sliding sheave clockwise and push it so that it separates from the secondary fixed sheave.

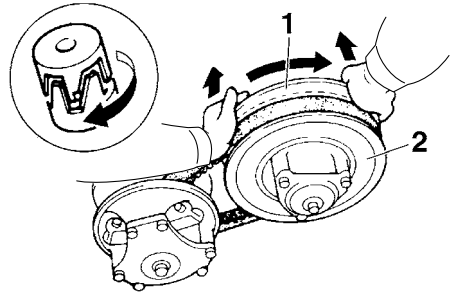

1. Secondary sliding sheave
2. Secondary fixed sheave
4. Pull the V-belt up over the secondary fixed sheave.

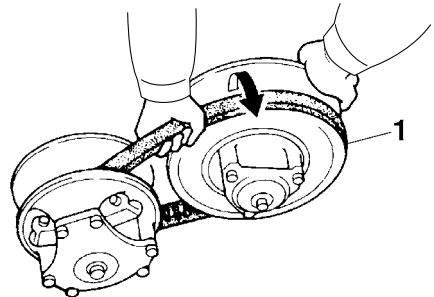

1. V-belt
5. Remove the V-belt from the secondary sheave assembly and primary sheave assembly.
6. Temporarily install the new V-belt on the secondary sheave assembly only, and then measure the V-belt position. Do not force the V-belt between the sheaves; the secondary sliding and fixed sheaves must touch each other.

Periodic maintenance and adjustment

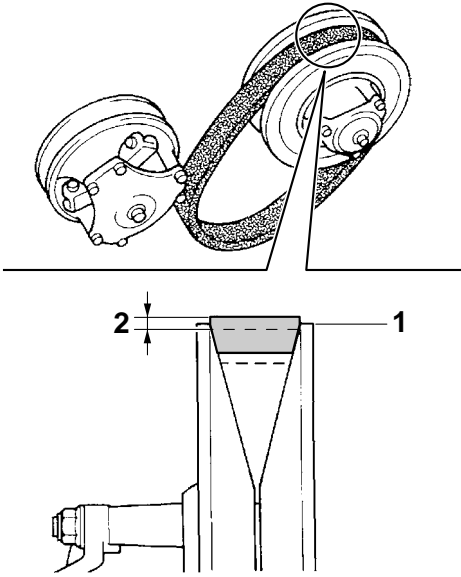

1. Edge of the secondary sheave assembly
2. Standard V-belt position

Standard V-belt position:

From 1.5 mm (0.06 in) above the edge of the secondary sheave assembly to 0.5 mm (0.02 in) below the edge

7. If the V-belt position is incorrect, adjust it by removing or adding a spacer on each V-belt position adjusting bolt.

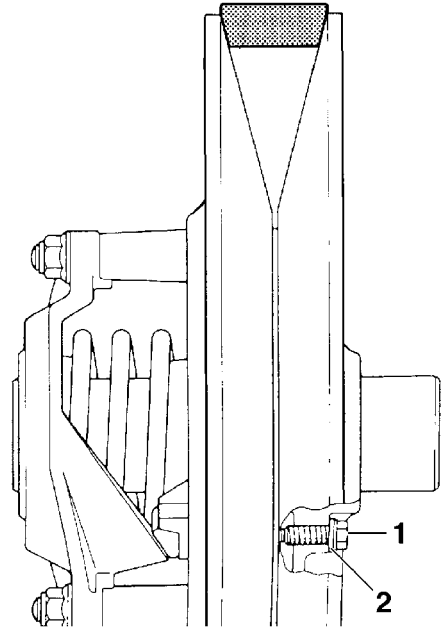

1. V-belt position adjusting bolt
2. Spacer

V-belt position	Adjustment
More than 1.5 mm (0.06 in) above the edge	Remove a spacer.
From 1.5 mm (0.06 in) above the edge to 0.5 mm (0.02 in) below the edge	Not necessary (it is correct).
More than 0.5 mm (0.02 in) below the edge	Add a spacer.

8. Tighten the V-belt position adjusting bolts.

V-belt position adjusting bolt tightening torque:

10 Nm (1.0 m·kgf, 7.2 ft·lbf)

9. Install the V-belt over the primary sheave assembly.

Periodic maintenance and adjustment

10. Rotate the secondary sliding sheave clockwise and push it so that it separates from the secondary fixed sheave.

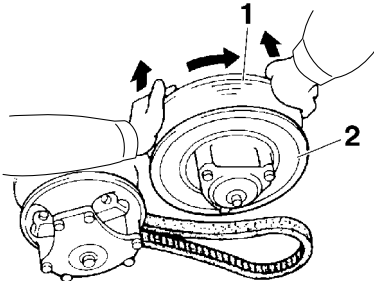

1. Secondary sliding sheave
 2. Secondary fixed sheave
11. Install the V-belt between the secondary sliding and fixed sheaves.

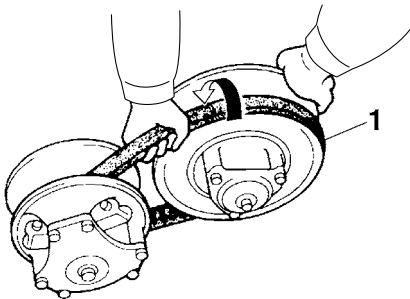

1. V-belt
12. Install the drive guard and close the shroud.

ESU12585

Drive chain housing

To check the drive chain housing oil level

1. Place the snowmobile on a level surface and apply the parking brake.
2. Remove the rubber cap.

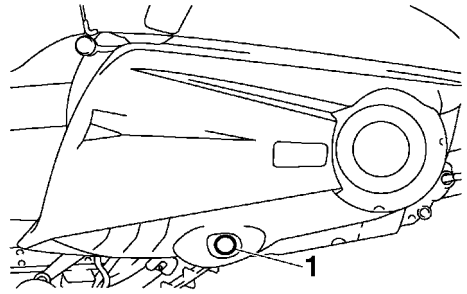

1. Rubber cap
3. Check the oil level through the check window, located on the drive chain housing. If the oil is below the minimum level mark, remove the dipstick and add sufficient oil of the recommended type to raise it to the maximum level mark.
NOTICE: Make sure that no foreign material enters the drive chain housing. [ECS00532]

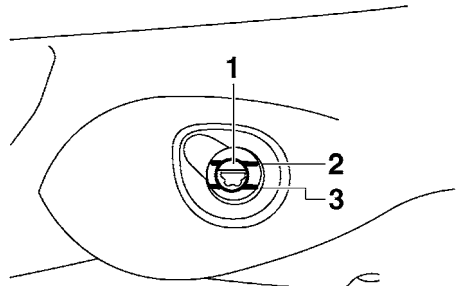

1. Drive chain oil level check window
2. Maximum level mark
3. Minimum level mark

Periodic maintenance and adjustment

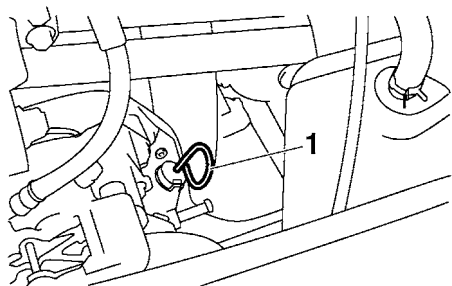

1. Dipstick

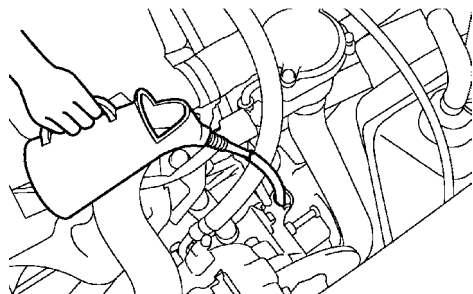

Recommended drive chain oil:
SAE 75W or 80W API GL-3 Gear oil

4. Install the dipstick, making sure to align the notch in the dipstick handle with the projection on the drive chain housing.

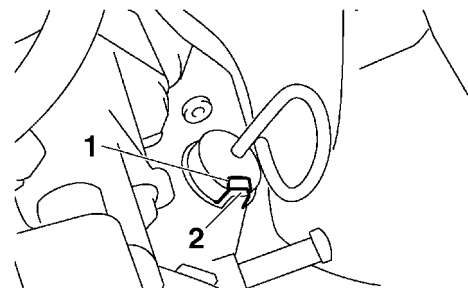

1. Notch
2. Projection

5. Install the rubber cap.

To adjust the chain tension

1. Loosen the locknut.

2. Turn the chain tension adjusting bolt clockwise until it is finger tight, and then loosen it 1/4 turn.

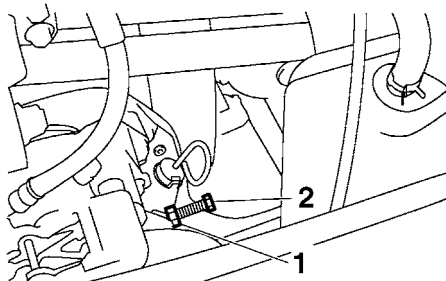

1. Locknut
2. Chain tension adjusting bolt
3. While holding the chain tension adjusting bolt with a wrench, tighten the locknut to the specified torque.

Tightening torque:
Locknut:
25 Nm (2.5 m·kgf, 18 ft·lbf)

ESU12135

Brake and parking brake

EWS00441

WARNING

- A soft, spongy feeling in the brake lever indicates a failure in the brake system.
- Do not operate the snowmobile if you find any problems in the brake system. You could lose braking ability, which could lead to an accident. Ask a Yamaha dealer to inspect and repair the brake system.

ECS00061

NOTICE

Make sure that the brake lever end does not project out over the handlebar end. This will help prevent brake lever damage when the snowmobile is placed on its side for service.

Periodic maintenance and adjustment

Test the brake at a low speed when starting out to make sure that it is working properly. If the brake does not provide proper braking performance, inspect the brake for wear or brake fluid leakage. (See the following section for more details.)

Checking the brake pads

Check the brake pads for wear according to the following procedure.

1. Place the snowmobile on a level surface and apply the parking brake.
2. Open the shroud.
3. Check the brake pads for wear.
If the brake pads reach the wear limit, ask a Yamaha dealer to replace them.

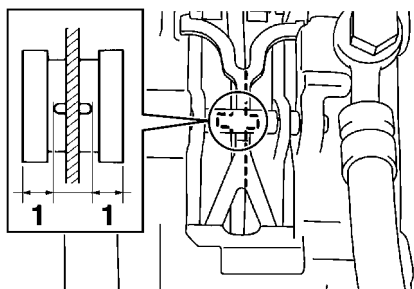

1. Brake pad wear limit

Brake pad wear limit:
4.7 mm (0.19 in)

4. Close the shroud.

Checking the parking brake pads

Check the parking brake pads for wear according to the following procedure.

1. Open the shroud.
2. Check the parking brake pads for wear by measuring the thickness of the pads.
If the parking brake pads reach the wear limit, ask a Yamaha dealer to replace them.

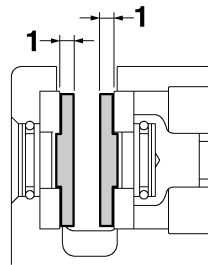

1. Parking brake pad wear limit

Parking brake pad wear limit:
1.2 mm (0.047 in)

3. Close the shroud.

To adjust the parking brake

As the parking brake pads wear, adjustment may be necessary to ensure proper brake performance.

1. Open the shroud.
2. Loosen the parking brake pad adjusting bolt locknut and the parking brake pad adjusting bolt.
3. Loosen the parking brake cable locknut.
4. Turn the parking brake cable adjusting bolt in or out to adjust the cable length.

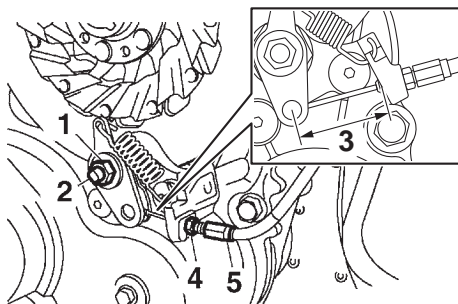

1. Parking brake pad adjusting bolt locknut
2. Parking brake pad adjusting bolt
3. Parking brake cable length
4. Parking brake cable locknut
5. Parking brake cable adjusting bolt

Periodic maintenance and adjustment

Parking brake cable length:
43.5–46.5 mm (1.713–1.831 in)

5. Tighten the parking brake cable locknut.
6. Turn the parking brake pad adjusting bolt in or out to adjust the clearance between the parking brake pads and the brake disc.

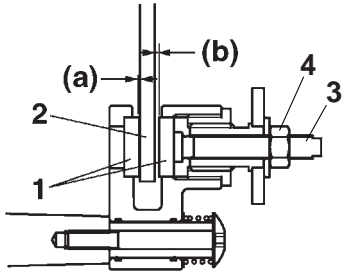

1. Parking brake pad
2. Brake disc
3. Parking brake pad adjusting bolt
4. Parking brake pad adjusting bolt locknut

Parking brake pad to brake disc clearance (a) + (b):
1.5–2.0 mm (0.059–0.079 in)

7. Tighten the parking brake pad adjusting bolt locknut.
8. Close the shroud.

Checking the brake fluid level

Before riding, check that the brake fluid is above the lower level. Check the brake fluid level with the top of the reservoir level. Replenish the brake fluid if necessary.

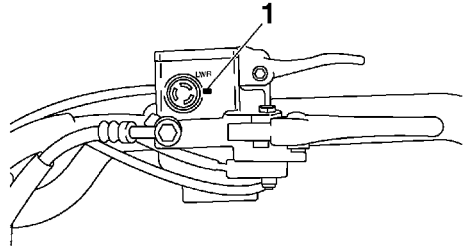

1. Lower level

Specified brake fluid:
DOT 4

EWS00821

WARNING

Improper maintenance can result in loss of braking ability. Observe these precautions:

- Insufficient brake fluid may allow air to enter the brake system, reducing braking performance.
- Clean the filler cap before removing. Use only DOT 4 brake fluid from a sealed container.
- Use only the specified brake fluid; otherwise, the rubber seals may deteriorate, causing leakage.
- Refill with the same type of brake fluid. Adding a brake fluid other than DOT 4 may result in a harmful chemical reaction.
- Be careful that water does not enter the brake fluid reservoir when refilling. Water will significantly lower the boiling point of the fluid and may result in vapor lock.

Periodic maintenance and adjustment

ECS01051

NOTICE

Brake fluid may damage painted surfaces or plastic parts. Always clean up spilled fluid immediately.

As the brake pads wear, it is normal for the brake fluid level to gradually go down. A low brake fluid level may indicate worn brake pads and/or brake system leakage; therefore, be sure to check the brake pads for wear and the brake system for leakage. If the brake fluid level goes down suddenly, have a Yamaha dealer check the cause before further riding.

Changing the brake fluid

EWS00472

WARNING

Make sure that the brake fluid and the following parts are replaced by a Yamaha dealer.

Brake fluid replacement is necessary when the following components are replaced during the periodic maintenance or if they are damaged or leaking.

- All oil seals of the master cylinder and caliper cylinder
- The brake hose

ESU14281

Extrovert drive sprocket

Check the extrovert drive sprocket for wear and damage. Replace if necessary.

To measure the drive sprocket wear

Measure the drive sprocket tooth width. If the tooth width is less than 28 mm (1.10 in), replace the drive sprocket.

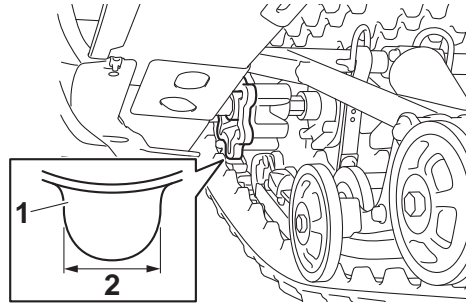

1. Drive sprocket tooth
2. Drive sprocket tooth width

ESU14291

Skis and ski runners

Checking the skis and ski runners

Check the skis and ski runners for wear and damage. Replace if necessary.

ECS00561

NOTICE

Avoid scratching the skis when loading and unloading the snowmobile, when riding in areas with little or no snow, or on sharp edges such as concrete, curbs, etc. This will wear or damage the skis.

For EUROPE

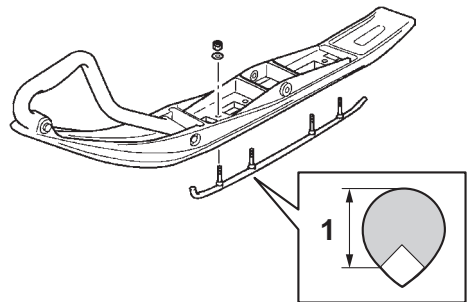

1. Ski runner wear limit

Periodic maintenance and adjustment

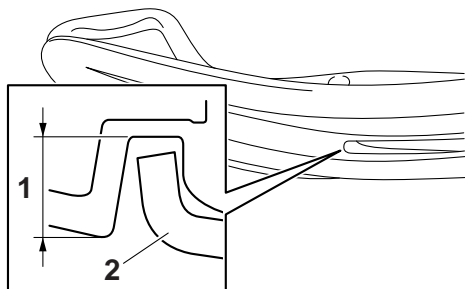

1. Ski wear limit
2. Ski runner

Ski runner wear limit:
8.0 mm (0.31 in)
Ski wear limit:
24.0 mm (0.94 in)

For RUSSIA

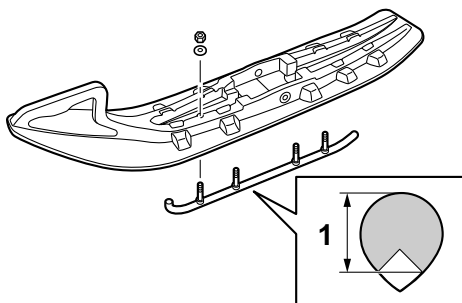

1. Ski runner wear limit

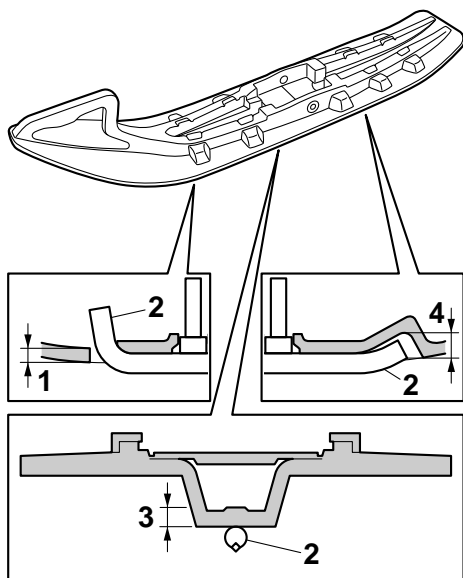

1. Ski wear limit (front)
2. Ski runner
3. Ski wear limit (center)
4. Ski wear limit (rear)

Ski runner wear limit:
8.0 mm (0.31 in)
Ski wear limit (front):
7.0 mm (0.28 in)
Ski wear limit (center):
6.0 mm (0.24 in)
Ski wear limit (rear):
12.0 mm (0.47 in)

Aligning the skis

1. Turn the handlebar so the skis face straight ahead.
2. Check the following for ski alignment:
 - Skis are facing forward.
 - Ski toe-out (distance A – distance B) is within specification.

Periodic maintenance and adjustment

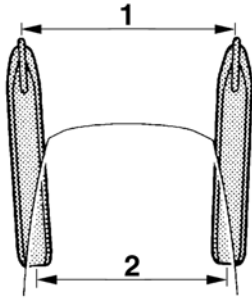

1. Distance A
2. Distance B

Ski toe-out (distance A – distance B):
0.0–15.0 mm (0.00–0.59 in)

TIP

Move the front tip of each ski fully inward before measuring or aligning.

3. If the alignment is not correct, consult a Yamaha dealer.

ESU12165

Steering system

Check the handlebar for excessive free play.

To check the handlebar

1. Push the handlebar up and down and back and forth.
2. Turn the handlebar slightly to the right and left.

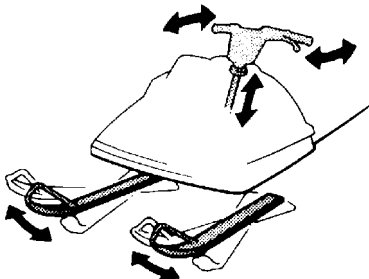

If excessive free play is felt, consult a Yamaha dealer.

To adjust the handlebar height

1. Remove the handlebar cover.

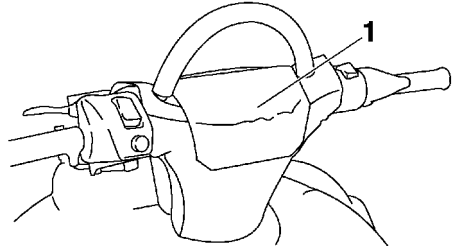

1. Handlebar cover
2. Loosen the handlebar bolts.

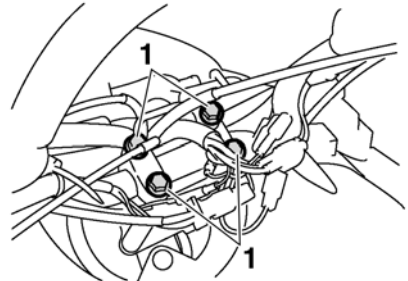

1. Handlebar bolt
3. Move the handlebar up or down to adjust the handlebar height to the desired position. **NOTICE:** Make sure that the projection on the handlebar is not installed into the area shown. [ECS00572]

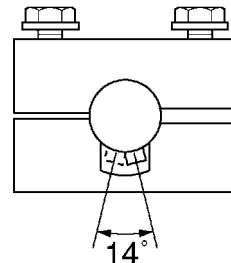

Periodic maintenance and adjustment

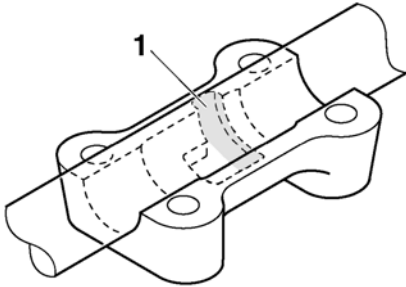
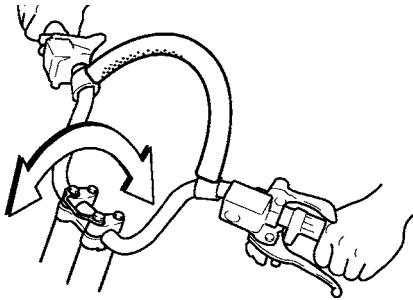

1. Area where projection cannot be installed
4. Tighten the front handlebar bolts to the specified torque, and then tighten the rear handlebar bolts to the specified torque. **NOTICE:** Make sure each handlebar holder is installed so that the smaller gap is facing forward. [ECS00583]

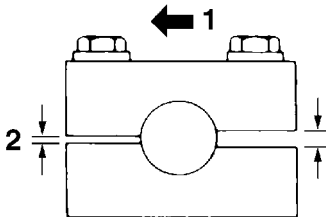

1. Forward
2. Small gap

Handlebar bolt tightening torque:
23 Nm (2.3 m·kgf, 17 ft·lbf)

5. Install the handlebar cover.

ESU12177

Drive track and slide runners

Drive track

EWS00482

WARNING

A broken track, track fittings or debris thrown by the drive track could be dangerous to an operator or bystanders. Observe the following precautions:

- Do not allow anyone to stand behind the snowmobile when the engine is running.
- When the rear of the snowmobile is raised to allow the drive track to spin, a suitable stand must be used to support the rear of the snowmobile. Never allow anyone to hold the rear of the snowmobile off the ground to allow the drive track to spin. Never allow anyone near a rotating drive track.
- Inspect the drive track condition frequently. Replace any damaged slide runner metal. Replace the drive track if it is damaged to the depth where fabric reinforcement material is visible or support rods are broken. Otherwise, track damage or failure could result in loss of braking ability and snowmobile control, which could cause an accident.

Checking the drive track

EWS00491

WARNING

Do not operate the snowmobile if you find damage to the drive track, or if it has been maladjusted. Drive track damage or failure could result in loss of braking ability and snowmobile control, which could cause an accident.

Check the drive track alignment and deflection, and check the track for wear and damage.

Periodic maintenance and adjustment

Adjust or replace if necessary. (See the following section for more details.)

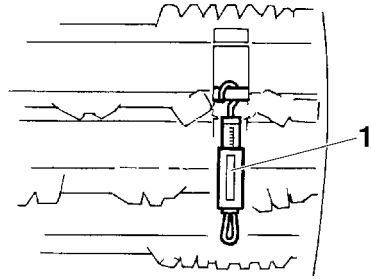
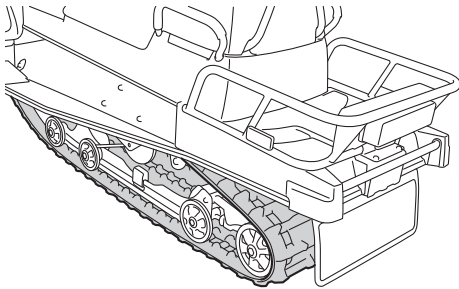

1. Spring scale

Checking the drive track alignment

1. Lift the rear of the snowmobile onto a suitable stand to raise the drive track off the ground.
2. Start the engine and rotate the drive track one or two turns. Stop the engine.
3. Check the drive track alignment with the slide runners. If the alignment is incorrect, adjust the drive track.

TIP

Measure the gap between the slide runner and the edge of the track window on both sides.

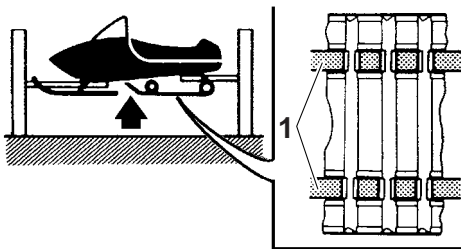

1. Slide runner

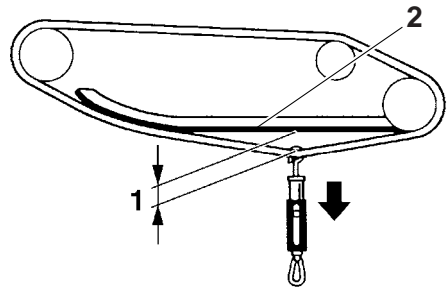

1. Drive track deflection
2. Slide runner

Standard drive track deflection:
30.0–35.0 mm (1.18–1.38 in)

Measuring the drive track deflection

1. Lay the snowmobile on its side.
2. Measure the drive track deflection with a spring scale. Pull at the center of the drive track with a force of 100 N (10 kgf, 22 lbf).

Adjusting the drive track alignment and deflection

1. Loosen the rear axle nut.

Periodic maintenance and adjustment

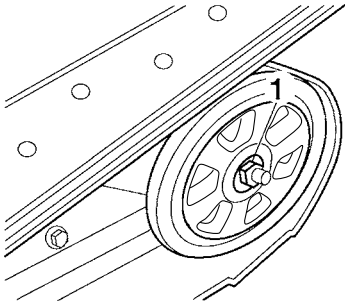

1. Rear axle nut
2. Lift the rear of the snowmobile onto a suitable stand to raise the drive track off the ground.
3. Start the engine and rotate the drive track one or two turns. Stop the engine.
4. Align the drive track by turning the left and right adjusting nuts.

Drive track alignment	Shifted to right	Shifted to left
Left adjusting nut	Turn out	Turn in
Right adjusting nut	Turn in	Turn out

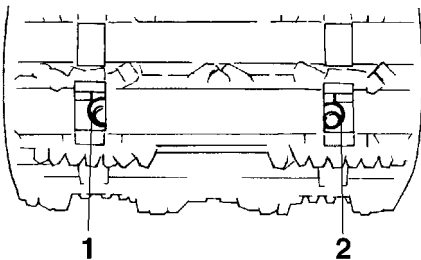

1. Left adjusting nut
2. Right adjusting nut

Shifted to right

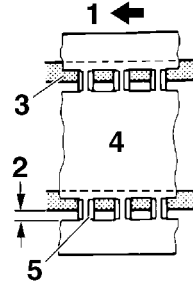

1. Forward
2. Gap
3. Slide runner
4. Drive track
5. Slide metal

Shifted to left

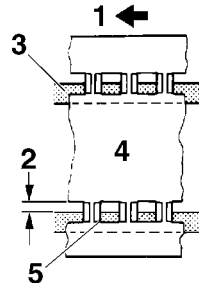

1. Forward
 2. Gap
 3. Slide runner
 4. Drive track
 5. Slide metal
5. Adjust the drive track deflection to specification. **NOTICE: The right and left adjusting nuts should be turned an equal amount.** [ECS00593]

Drive track deflection	More than specified	Less than specified
Left adjusting nut	Turn in	Turn out
Right adjusting nut	Turn in	Turn out

Periodic maintenance and adjustment

- Recheck alignment and deflection. If necessary, repeat steps 3 to 5 until the proper adjustment is achieved.
- Lower the snowmobile to the ground.
- Tighten the rear axle nut.

Rear axle nut tightening torque:
75 Nm (7.5 m·kgf, 54 ft·lbf)

Slide runners

Check the slide runners for wear and damage.

If the slide runners reach the wear limit, they should be replaced.

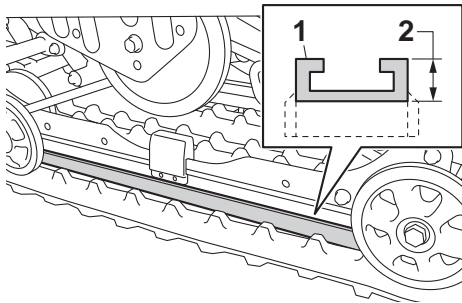

- Slide runner
- Wear limit height

Slide runner wear limit height:
10.5 mm (0.41 in)

ECS00351

NOTICE

Ride on fresh snow frequently. Operating on ice or hard-packed snow will rapidly wear the slide runners.

ESU12199

Lubrication

Lubricate the following points with the specified grease.

EWS00512

WARNING

Do not grease the throttle cable because it could become frozen, which could cause loss of control. Apply a dab of grease onto the cable end only.

TIP

For parts equipped with a grease nipple, use a grease gun.

Lubricants:
Brake lever:
Silicone grease
Other lubrication points:
Low-temperature grease

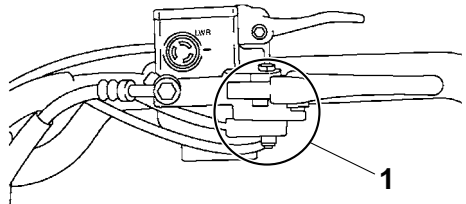

- Lubrication point

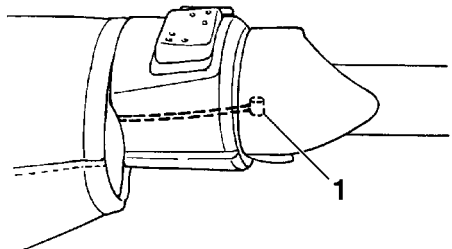

- Throttle cable end

Periodic maintenance and adjustment

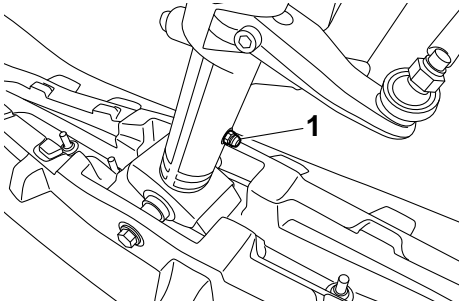

1. Grease nipple

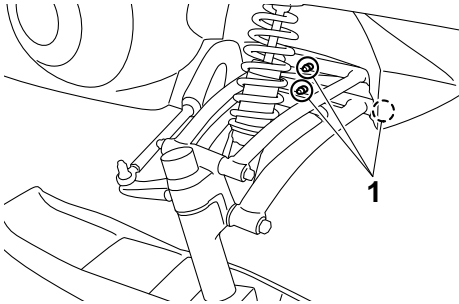

1. Grease nipple

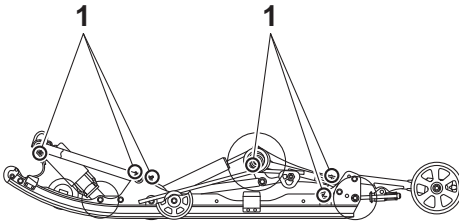

1. Grease nipple

ESU12213

Replacing a headlight bulb

1. Open the shroud.
2. Disconnect the headlight coupler.
3. Remove the bulb holder cover.

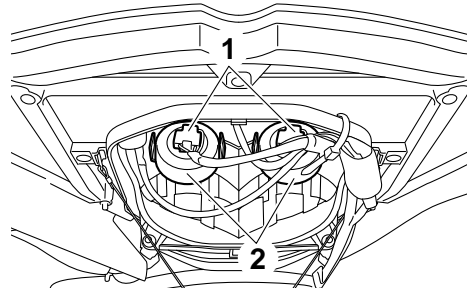

1. Headlight coupler
2. Bulb holder cover
4. Unhook the bulb holder, and then remove the burnt-out bulb.

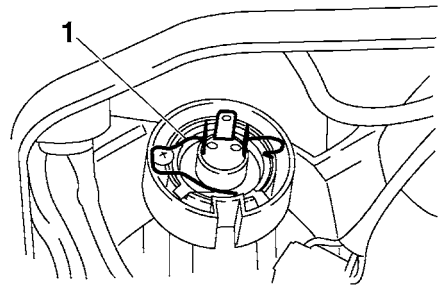

1. Bulb holder
5. Install the new bulb, and then hook the bulb holder onto the headlight unit.
NOTICE: Keep oil and your hands away from the glass part of the bulb or its life and illumination will be affected. If the glass is oil stained, thoroughly clean it with a cloth moistened with alcohol or lacquer thinner. [ECS00622]

Periodic maintenance and adjustment

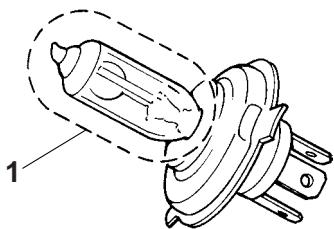

1. Do not touch the glass part of the bulb.

Bulb type:
Halogen bulb

6. Install the bulb holder cover, and then connect the headlight coupler.
7. Close the shroud.

ESU12251

Adjusting the headlight beams

1. Open the shroud.
2. Remove the locking pin.

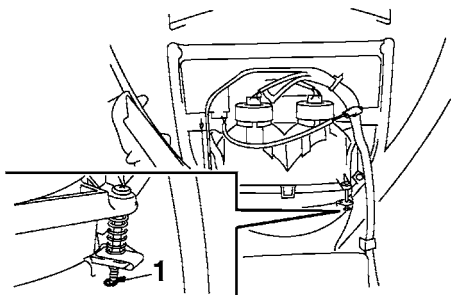

1. Locking pin
3. Turn the headlight beam adjusting screws in or out to adjust the headlight beams. The headlight beams move as follows depending on the turning direction of the headlight beam adjusting screws.
 - Direction (a): Down and to the left
 - Direction (b): Up and to the right
 - Direction (c): Down and to the right
 - Direction (d): Up and to the left

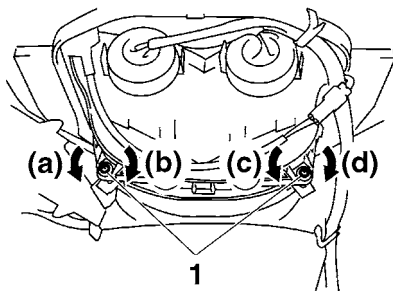

1. Headlight beam adjusting screw
4. Install the locking pin, and then close the shroud.

ESU12291

Fittings and fasteners

Check the tightness of the fittings and fasteners.

Tighten in proper sequence and torque if necessary.

ESU14021

Battery

The battery is located under the air filter case. (See page 72.)

This model is equipped with a VRLA (Valve Regulated Lead Acid) battery. There is no need to check the electrolyte or to add distilled water. However, the battery lead connections need to be checked and, if necessary, tightened.

EWS00541

WARNING

Battery electrolyte is poisonous and dangerous. It contains sulfuric acid and can cause severe burns. Avoid contact with skin, eyes, or clothing.

ANTIDOTE:

- **EXTERNAL:** Flush with water.
- **INTERNAL:** Drink large quantities of water or milk. Follow with milk of magnesia, beaten egg, or vegetable oil. Call physician immediately.
- **EYES:** Flush with water for 15 minutes and get prompt medical attention.

Periodic maintenance and adjustment

Batteries produce explosive gases. Keep sparks, flame, cigarettes, etc. away. Ventilate when charging or using in an enclosed space. Always shield your eyes when working near batteries.

KEEP OUT OF THE REACH OF CHILDREN.

Charge or have a Yamaha dealer charge the battery as soon as possible if it seems to have discharged. Keep in mind that the battery tends to discharge more quickly if the snowmobile is equipped with electrical accessories.

EWS00611

WARNING

- Never smoke around the battery while it is being charged. Sparks may ignite the hydrogen gas created by the battery.
- Disconnect the negative lead first, then the positive lead from the battery.
- Connect the positive lead first, then the negative lead to the battery when installing the battery.
- Never connect the battery to or disconnect it from the snowmobile while it is being charged. Sparks may ignite the hydrogen gas created by the battery.
- Make sure that the battery terminals are tight.

ECS00844

NOTICE

- To charge a VRLA (Valve Regulated Lead Acid) battery, a special (constant-voltage) battery charger is required. Using a conventional battery charger will damage the battery.
- Do not charge the battery quickly.

ESU12324

Replacing a fuse

EWS00551

WARNING

Be sure to use the specified fuse. A wrong fuse could cause electrical system damage or A FIRE HAZARD.

ECS00632

NOTICE

Be sure to turn the main switch to the off position and disconnect the negative battery lead to prevent accidental short-circuiting.

1. Open the shroud.
2. Unhook the air filter case fastener.

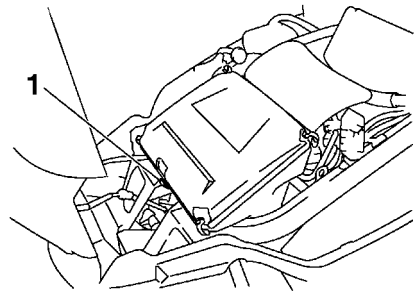

1. Air filter case fastener
3. Loosen the joint clamp screws.

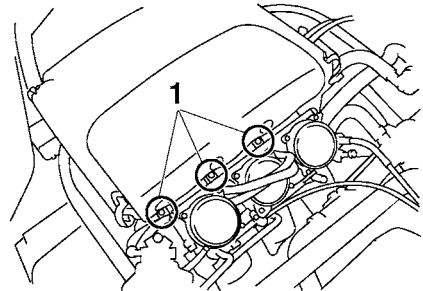

1. Joint clamp screw
4. Slide the oil tank breather hose clamp away from the air filter case, and then disconnect the oil tank breather hose.

Periodic maintenance and adjustment

5. Lift up the air filter case, slide the crankcase breather hose clamp (air filter case side) down, disconnect the crankcase breather hose from the air filter case, and then remove the air filter case.

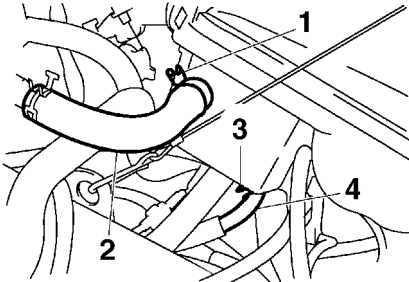

1. Oil tank breather hose clamp
2. Oil tank breather hose
3. Crankcase breather hose clamp (air filter case side)
4. Crankcase breather hose

6. Disconnect the negative battery lead.
7. Replace the blown fuse with one of the proper amperage.

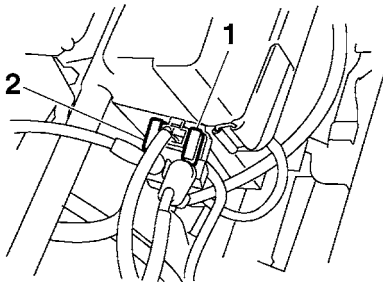

1. Main fuse
2. Spare main fuse

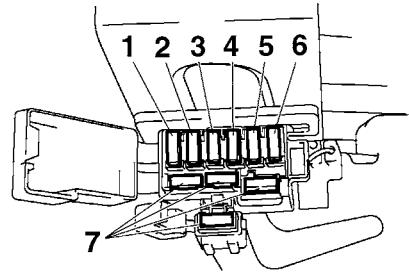
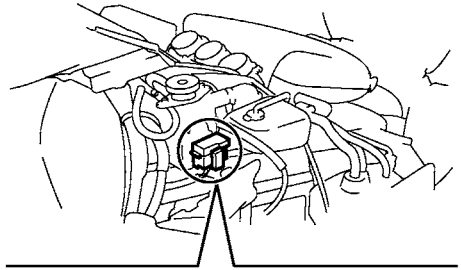

1. "HEAD" (headlight) fuse
2. "SIG" (signaling system) fuse
3. "DC TERM" (auxiliary DC jack) fuse
4. "C/W" (carburetor warmer) fuse
5. "IGN" (ignition) fuse
6. "FAN" (radiator fan) fuse
7. Spare fuse

Periodic maintenance and adjustment

Specified fuses:

Main fuse:

30.0 A

Spare main fuse:

30.0 A

Headlight fuse:

20.0 A

Signaling system fuse:

10.0 A

Auxiliary DC jack fuse:

3.0 A

Carburetor warmer fuse:

20.0 A

Ignition fuse:

15.0 A

Radiator fan fuse:

15.0 A

Spare fuses:

20.0 A, 15.0 A, 10.0 A, 3.0 A

8. Connect the negative battery lead.
9. Install the air filter case by reversing the removal steps. **NOTICE: Be sure to connect the breather hoses securely when installing the air filter case.**

[ECS00642]

10. Close the shroud.

TIP

If the fuse immediately blows again, ask a Yamaha dealer to inspect the snowmobile.

ESU12376

Engine turns over but does not start

1. Fuel system

- No fuel supplied to combustion chamber
 - No fuel in tank:
Supply fuel.
 - ↓
 - Clogged fuel line:
Clean fuel line.
 - ↓
 - Clogged carburetor:
Clean carburetor.
- Fuel supplied to combustion chamber
 - Flooded engine (too much choke):
Crank engine with throttle open or wipe spark plugs dry.

2. Electrical system

- Poor spark or no spark
 - Spark plugs are dirty with carbon or are wet:
Remove carbon or wipe spark plugs dry. Replace if necessary.
 - ↓
 - Faulty ignition system:
Ask a Yamaha dealer to check.
 - ↓
 - T.O.R.S. malfunction:
Disconnect throttle switch connectors and connect wire harness connectors together to bypass T.O.R.S. **WARNING! Before bypassing the T.O.R.S., make sure that the throttle returns properly to the fully closed position. The T.O.R.S. is an important safety device; in the case of a malfunction, take the snowmobile to a Yamaha dealer immediately for repair.** [EWS00562]

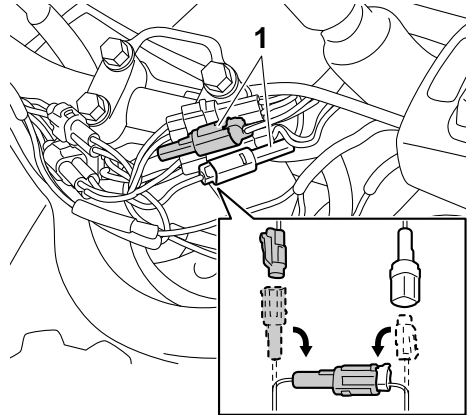

1. Throttle switch connector

3. Compression

- Insufficient
 - Loose cylinder head nuts:
Tighten nuts properly.
 - ↓
 - Worn or damaged gasket:
Replace gasket.
 - ↓
 - Worn or damaged piston and cylinder:
Ask a Yamaha dealer to check.

Discharged battery

If the battery is discharged, the engine can be started using a fully-charged 12-volt battery and jumper cables. Two connecting leads have been provided for jump-starting the snowmobile. Due to the rubber engine mounting, the snowmobile frame is not a suitable grounding point for jump-starting the engine.

EWS00571

! WARNING

- Connect the jumper cables only to the connecting lead terminals. Do not connect them to the frame or any wire or other lead.

Troubleshooting

- When connecting the jumper cables, do not contact the jumper cables or connecting lead terminals to each other or to the frame or any metal part of the snowmobile. This can cause electrical system damage or A FIRE HAZARD.
- Be sure to pull the lead covers back over the terminals completely. If the terminals are exposed, they could come into contact with the frame or a metal part of the snowmobile and this can cause electrical system damage or A FIRE HAZARD.

ECS00651

NOTICE

Use the connecting leads to jump-start the snowmobile only. Do not use the connecting leads for any other purpose.

To start the engine using the booster battery

1. Apply the parking brake and turn the key to the off position.
2. Open the shroud.
3. Remove the red (+) connecting lead from the lead holder and move it away from the black (-) connecting lead. **NOTICE:** Be sure to connect the red (+) jumper cable to the red (+) connecting lead and the black (-) jumper cable to the black (-) connecting lead. Do not reverse the connections. [ECS00662]

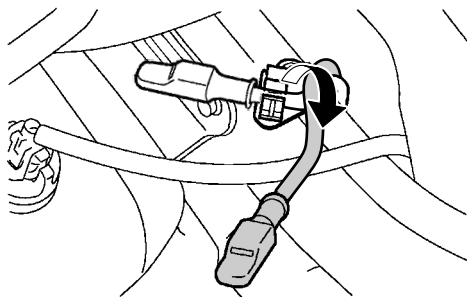
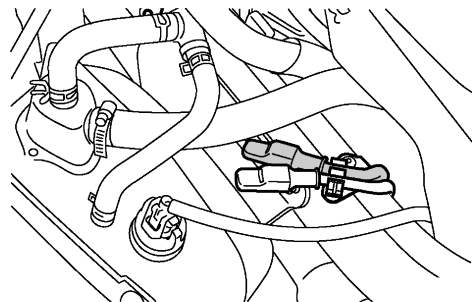

4. Pull the red (+) connecting lead cover to expose the terminal through the slit in the cover, and then connect the red (+) jumper cable to the red (+) connecting lead.

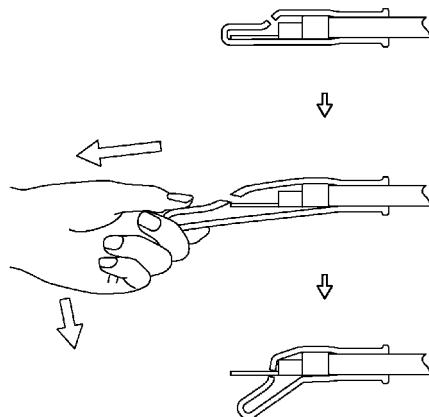

5. Connect the other end of the red (+) jumper cable to the positive (+) terminal of the booster battery.
6. Connect the black (-) jumper cable to the negative (-) terminal of the booster battery.

7. Pull the black (-) connecting lead cover to expose the terminal through the slit in the cover, and then connect the black (-) jumper cable to the black (-) connecting lead.

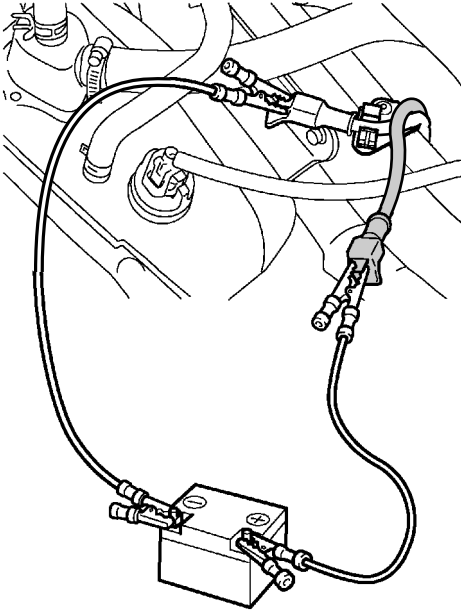

8. Start the engine.
9. Disconnect the black (-) jumper cable from the black (-) connecting lead, and then pull the cover completely over the lead terminal.
10. Disconnect the black (-) jumper cable from the negative (-) terminal of the battery used to jump-start the engine.
11. Disconnect the red (+) jumper cable from the positive (+) terminal of the battery used to jump-start the engine.
12. Disconnect the red (+) jumper cable from the red (+) connecting lead, and then pull the cover completely over the lead terminal.

13. Install the red (+) connecting lead into the lead holder.
14. Close the shroud.

TIP

Make sure that both the red (+) connecting lead and the black (-) connecting lead are seated securely in the lead holders.

Electric starter does not operate or operates slowly

- Engine stop switch is pushed in: Pull it out.
- Faulty wire connections: Check connections or ask a Yamaha dealer to check.
- Discharged battery: Charge battery or see “Discharged battery” above.
- Seized engine: Seizure is caused by poor lubrication, inadequate fuel, or an air leak. Ask a Yamaha dealer to check.
- “Hydrostatic lock” occurs when fuel has filled cylinders during transportation of vehicle: Remove spark plugs and turn engine over several times with ignition off to expel excess fuel. Ask a Yamaha dealer to check.

Engine power is low

- Low coolant temperature indicator light is flashing: Warm engine up.
- Faulty spark plugs: Clean or replace spark plugs.
- Incorrect carburetor jetting for altitude or temperature: Ask a Yamaha dealer to check.
- Improper fuel flow: See “Engine turns over but does not start—Fuel system” above.
- Incorrect V-belt clutch settings for altitude or conditions: Ask a Yamaha dealer to check.

Engine constantly backfires or misfires

- Faulty spark plugs: Replace spark plugs.

Troubleshooting

- Clogged fuel system: See “Engine turns over but does not start–Fuel system” above.
- Malfunctioning T.O.R.S.: See “Engine turns over but does not start–Electrical system” above.

Engine overheats

- Insufficient coolant: Add coolant.
- Air in cooling system: Bleed cooling system or ask a Yamaha dealer to check.
- Leaking coolant: Ask a Yamaha dealer to check.

Snowmobile does not move

- Malfunctioning V-belt clutch: Ask a Yamaha dealer to check.
- Drive track does not move: Foreign object is caught in drive track, or slide runners have melted to slide metal due to lack of lubrication.
- Tight, loose, or broken drive chain: Ask a Yamaha dealer to check.

V-belt twists

- Improper V-belt: Replace with correct V-belt.
- Incorrect V-belt clutch offset: Ask a Yamaha dealer to check.
- Loose or broken engine mount(s): Ask a Yamaha dealer to check.

V-belt slips or becomes extremely hot

- Oily or dirty V-belt or primary and secondary sheave assembly surfaces: Clean.
- Problem with driveline: See “V-belt twists” above.

Engine does not upshift or downshift properly or engages harshly

- Worn or damaged V-belt: Replace V-belt or ask a Yamaha dealer to check.
- Incorrect V-belt clutch settings for altitude or conditions: Ask a Yamaha dealer to check.

- Worn or sticking primary sheave assembly: Ask a Yamaha dealer to check.
- Worn or sticking secondary sheave assembly: Ask a Yamaha dealer to check.

Noise or excessive vibration in drive chain and sprockets

- Broken V-belt clutch components: Ask a Yamaha dealer to check.
- Worn or damaged bearings: Ask a Yamaha dealer to check.
- Worn or damaged V-belt with flat spots: Replace.
- Worn or damaged idler wheels or shafts: Ask a Yamaha dealer to check.
- Worn or damaged drive track: Ask a Yamaha dealer to check.

ESU12427

Long-term storage of your snowmobile will require some preventive procedures to guard against deterioration.

Engine

Perform the following steps to protect the cylinders, piston rings, etc., from corrosion.

1. Remove the spark plug caps and spark plugs.
2. Pour a teaspoonful of engine oil into each spark plug bore.
3. Install the spark plug caps onto the spark plugs, and then place the spark plugs on the cylinder head so that the electrodes are grounded. (This will limit sparking during the next step.)
4. Turn the engine over several times with the starter. (This will coat the cylinder walls with oil.) **WARNING! To prevent damage or injury from sparking, make sure to ground the spark plug electrodes while turning the engine over.**

[EWS00602]

5. Remove the spark plug caps from the spark plugs, and then install the spark plugs and the spark plug caps.

Fuel

Drain the fuel tank and carburetor float bowls. This will prevent fuel deposits from building up.

Chassis

1. Lubricate all specified points with grease. (See page 69 for detailed information about the lubrication points.)
2. Loosen the drive track and block up the chassis so that the track is suspended above the ground.
3. Clean the exterior of the snowmobile and apply a rust inhibitor.

4. Store the snowmobile in a dry, well-ventilated place with a porous cover placed over it.
5. Keep the snowmobile on a level surface during storage or while transporting.

ECS00871

NOTICE

- **Improper cleaning can damage plastic parts such as shroud, covers, windshields, headlight lenses, meter lenses, etc. Use only a soft, clean cloth or sponge with mild detergent and water to clean plastic.**
- **Do not use any harsh chemical products on plastic parts. Be sure to avoid using cloths or sponges which have been in contact with strong or abrasive cleaning products, solvent or thinner, fuel (gasoline), rust removers or inhibitors, brake fluid, antifreeze or electrolyte.**
- **Do not use high-pressure washers or steam-jet cleaners since they cause water seepage and deterioration in the following areas: seals (of the slide rail suspension, front suspension and brakes), electric components (couplers, connectors, instruments, switches and lights), breather hoses and vents.**
- **For snowmobiles equipped with a windshield: Do not use strong cleaners or hard sponges as they will cause dulling or scratching. Some cleaning compounds for plastic may leave scratches on the windshield. Test the product on a small hidden part of the windshield to make sure that it does not leave any marks. If the windshield is scratched, use a quality plastic polishing compound after washing.**

Storage

Battery

Remove the battery from the snowmobile. Store it in a cool, dry place that is above 0 °C (32 °F), but less than 30 °C (90 °F). Check the condition of the battery once a month, and charge it as necessary. **NOTICE: Always keep the battery charged. Storing a discharged battery can cause permanent battery damage.** [ECS00692]

TIP

Before installing the battery, have a Yamaha dealer inspect and fully charge it.

ESU1246F

Dimensions:

- Overall length:
 - 3260 mm (128.3 in) (RUS)
 - 3270 mm (128.7 in) (FIN)(SWE)
- Overall width:
 - 1165 mm (45.9 in) (FIN)(SWE)
 - 1215 mm (47.8 in) (RUS)
- Overall height:
 - 1420 mm (55.9 in)
- Weight:
 - Mass in running order:
 - 388.0 kg (855 lb)
- Ski stance:
 - 990 mm (39.0 in)

Engine:

- Type:
 - Liquid cooled 4-stroke, 12 valves
- Cylinder arrangement:
 - Inline 3-cylinder
- Displacement:
 - 973 cm³
- Bore × stroke:
 - 79.0 × 66.2 mm (3.11 × 2.61 in)
- Idling speed:
 - 1300–1500 r/min
- Engine oil:
 - Recommended grade:
 - API service SG type or higher, JASO standard MA
 - Recommended brand:
 - YAMALUBE
 - Type:
 - SAE 0W-30
- Carburetor:
 - Model × quantity:
 - CVK40 × 3
- Fuel:
 - Recommended fuel:
 - Min 91 RON UNLEADED GASOLINE ONLY (RUS)
 - Min 95 RON UNLEADED GASOLINE ONLY (FIN)(SWE)
 - Minimum research octane:
 - 91 (RUS)
 - 95 (FIN)(SWE)
- Starting system:
 - Electric starter

Noise level and vibration level:

- Noise level (77/311/EEC):
 - 87 dB(A)@4250 r/min (FIN)(SWE)
- A-weighted sound power level:
 - 99 dB(A)@4250 r/min (FIN)(SWE)
- Vibration on seat (EN1032, ISO 5008):
 - Not exceed 0.5 m/s² (FIN)(SWE)
- Vibration on handlebar (EN1032, ISO 5008):
 - Not exceed 2.5 m/s² (FIN)(SWE)

Chassis:

- Drive track:
 - Material:
 - Molded rubber, fiberglass-rod reinforced
 - Type:
 - Extrovert drive type
 - Width:
 - 500 mm (19.7 in)
 - Deflection:
 - 30.0–35.0 mm (1.18–1.38 in)
 - Length on ground:
 - 1104 mm (43.5 in)
- Rear suspension:
 - Type:
 - Slide rail suspension
- Track sprocket wheel:
 - Material:
 - Polyethylene
 - Number of teeth:
 - 7
- Transmission:
 - Clutch type:
 - Automatic centrifugal engagement
 - Overall reduction ratio:
 - 7.60–2.00 : 1
 - Overall reduction ratio [L]:
 - 10.16–2.67 : 1
 - Sheave distance:
 - 267.0–270.0 mm (10.51–10.63 in)
 - Sheave offset:
 - 13.5–16.5 mm (0.53–0.65 in)
 - Engagement speed (Subject to change according to elevation settings.):
 - 2200–2600 r/min
 - Shift speed [Subject to change according to elevation settings. Usually achieved after approximately 800 m (0.5 mi) traveled]:
 - 8000–8750 r/min
 - Drive chain type:
 - Silent chain enclosed in oil bath

Specifications

Drive chain housing oil:

Type:

SAE 75W or 80W API GL-3 Gear oil

Capacity:

0.35 L (0.37 US qt, 0.31 Imp.qt)

Reverse system:

Yes

Primary reduction ratio:

3.80–1.00 : 1

Secondary reduction ratio [D]:

40/20 (2.00)

Secondary reduction ratio [L]:

40/20 × 29/47 × 52/24 (2.67)

Secondary reduction ratio [R]:

2.46

Fuel tank capacity:

40.0 L (10.57 US gal, 8.80 Imp.gal)

Engine oil quantity:

With oil filter cartridge replacement:

3.0 L (3.17 US qt, 2.64 Imp.qt)

Without oil filter cartridge replacement:

2.8 L (2.96 US qt, 2.46 Imp.qt)

Total amount:

3.7 L (3.91 US qt, 3.26 Imp.qt)

Brake:

Type:

Hydraulic disc type (ventilated disc)

Operation:

Handle lever, left-hand operated

Throttle:

Operation:

Handle lever, right-hand operated

Electrical system:

Ignition system:

TCI

Spark plug:

Manufacturer:

NGK

Model:

CR8E

Gap:

0.7–0.8 mm (0.028–0.031 in)

Battery:

Model:

YTX20L-BS

Voltage, capacity:

12 V, 18.0 Ah

Ten-hour rate amperage:

1.8 A

Bulb voltage, wattage × quantity:

Headlight:

12 V, 60/55 W × 2

Headlight bulb type:

Halogen bulb

Tail/brake light:

12 V, 5/21 W × 1

Meter lighting:

14 V, 50 mA × 6

High beam indicator light:

14 V, 80 mA × 1

Warning light:

14 V, 80 mA × 1

Low coolant temperature indicator light:

14 V, 80 mA × 1

ESU14251

For EUR only

The figures quoted are emission levels and are not necessarily safe working levels. Whilst there is a correlation between the emission and exposure levels, this cannot be used reliably to determine whether or not further precautions are required. Factors that influence the actual level of exposure of workforce include the characteristics of the work room, the other sources of noise, etc. i.e. the number of machines and other adjacent processes, and the length of time for which an operator is exposed to the noise. Also the permissible exposure level can vary from country. This information, however, will enable the user of the machine to make a better evaluation of the hazard and risk.

ESU14221

Identification number records

Record the frame serial number and engine serial number (Primary ID) in the spaces provided for assistance when ordering spare parts from a Yamaha dealer.

Also, record and keep the ID numbers in a separate place in case the snowmobile is stolen.

Frame serial number

The frame serial number is the seventeen-digit number stamped on the frame of the snowmobile.

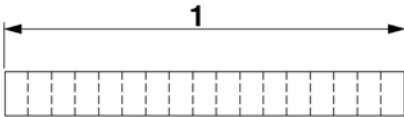

1. Frame serial number

Engine serial number (Primary ID)

The engine serial number is stamped in the location as shown.



1. Engine serial number

ESU12492

WARRANTY

If doubt exists as to the cause and cure of a problem, consult your authorized Yamaha snowmobile dealer. This is especially important during the warranty period, as unauthorized, haphazard, or improper repairs can void the warranty. Remember that your authorized Yamaha dealer has the special tools, techniques, and spare parts necessary for proper repair of your snowmobile.

Always consult your Yamaha dealer if you are in doubt as to proper specifications and/or maintenance procedures. Occasionally, printing errors or production changes will result in incorrect documentation in this manual.

Until you are thoroughly familiar with this model, consult your Yamaha dealer before attempting any maintenance. Should further maintenance or service information be desired, service manuals can be purchased from your local authorized Yamaha snowmobile dealer.

Index

A		L	
Air filter, checking	49	Location of the important labels	1
Auxiliary DC jack	20	Louvers	23
B		Low coolant temperature indicator light	15
Battery.....	71	Lubrication	69
Brake and parking brake.....	60	M	
Brake lever	20	Main switch	13
Break-in.....	33	Multi-function meter unit.....	14
C		O	
Carburetor coolant shut-off lever.....	22	Oil level warning indicator	18
Carburetors	50	P	
Center shock absorber and rear torsion springs, adjusting spring preload	28	Parking brake lever	21
Coolant temperature warning indicator ...	18	Part locations	11
Cooling system	55	Passenger grip warmer switch.....	23
D		Periodic maintenance chart for the emission control system.....	42
Drive chain housing.....	59	Pre-operation check list	30
Drive guard.....	22	R	
Drive track and slide runners	66	Rear storage area and rear carrier	24
Drive track life, maximizing	37	Recommended equipment	45
Driving	38	Riding your snowmobile.....	33
E		S	
Engine idling speed, adjusting	47	Safety information	9
Engine oil and oil filter cartridge.....	50	Self-diagnosis device.....	18
Engine stop switch.....	19	Shift lever	21
Extrovert drive sprocket.....	63	Shock absorbers, front, adjusting spring preload.....	27
F		Shroud and right side cover, opening and closing, removing and installing	45
Fittings and fasteners.....	71	Skis and ski runners.....	63
Fuel	26	Sliding frame extension, adjusting spring preload.....	29
Fuel level warning indicator	17	Spark plugs, checking	46
Fuel meter and grip/thumb warmer level indicator.....	16	Specifications.....	81
Fuse, replacing.....	72	Starter (choke) lever	13
G		Starting the engine	32
General maintenance and lubrication chart.....	43	Steering system	65
Grip/thumb warmer adjusting switch.....	19	Stopping the engine.....	39
H		Storage.....	79
Headlight beam switch	19	Storage areas.....	23
Headlight beams, adjusting	71	Storage compartment	23
Headlight bulb, replacing	70	Storage pouches.....	24
High beam indicator light.....	15	Strap.....	38
High-altitude settings.....	50	Suspension	27
I			
Identification numbers	83		

T

Throttle lever	13
Throttle lever free play, adjusting.....	47
Throttle override system (T.O.R.S.).....	14
Throttle override system (T.O.R.S.), checking	48
Tool kit	45
Tow hitch bracket	25
Transporting	39
Troubleshooting	75

V

Valve clearance	50
V-belt.....	56
V-belt holders.....	22



Printed in Japan
2014.04-0.3×1 CR

Printed on recycled paper