



OWNER'S MANUAL

SR

SR125

3MW-28199-E3

Welcome to the Yamaha world of motorcycling!

As the owner of a SR125, you are benefiting from Yamaha's vast experience in and newest technology for the design and the manufacture of high-quality products, which have earned Yamaha a reputation for dependability.

Please take the time to read this manual thoroughly, so as to enjoy all your SR125's advantages. The owner's manual does not only instruct you in how to operate, inspect and maintain your motorcycle, but also in how to safeguard yourself and others from trouble and injury.

In addition, the many tips given in this manual will help to keep your motorcycle in the best possible condition. If you have any further questions, do not hesitate to contact your Yamaha dealer.

The Yamaha team wishes you many safe and pleasant rides. So, remember to put safety first!

IMPORTANT MANUAL INFORMATION

Particularly important information is distinguished in this manual by the following notations:



The Safety Alert Symbol means ATTENTION! BECOME ALERT! YOUR SAFETY IS INVOLVED!



Failure to follow WARNING instructions could result in severe injury or death to the motorcycle operator, a bystander or a person inspecting or repairing the motorcycle.

CAUTION:

A CAUTION indicates special precautions that must be taken to avoid damage to the motorcycle.

NOTE:

A NOTE provides key information to make procedures easier or clearer.

NOTE:

- This manual should be considered a permanent part of this motorcycle and should remain with it even if the motorcycle is subsequently sold.
 - Yamaha continually seeks advancements in product design and quality. Therefore, while this manual contains the most current product information available at the time of printing, there may be minor discrepancies between your motorcycle and this manual. If there is any question concerning this manual, please consult your Yamaha dealer.
-

IMPORTANT MANUAL INFORMATION

EW000002

 **WARNING**

PLEASE READ THIS MANUAL CAREFULLY AND COMPLETELY BEFORE OPERATING THIS MOTORCYCLE.

IMPORTANT MANUAL INFORMATION

EAU03337

**SR125
OWNER'S MANUAL
© 2001 by Yamaha Motor Co., Ltd.
1st Edition, January 2001
All rights reserved.
Any reprinting or unauthorized use
without the written permission of
Yamaha Motor Co., Ltd.
is expressly prohibited.
Printed in Japan.**

1	GIVE SAFETY THE RIGHT OF WAY	1-1	4	PRE-OPERATION CHECKS	4-1
				Pre-operation check list.....	4-1
2	DESCRIPTION	2-1	5	OPERATION AND IMPORTANT RIDING	
	Left view	2-1		POINTS.....	5-1
	Right view.....	2-2		Starting the engine	5-1
	Controls/Instruments	2-3		Starting a warm engine	5-3
3	INSTRUMENT AND CONTROL FUNCTIONS ...	3-1		Shifting	5-4
	Main switch/steering lock	3-1		Recommended shift points	
	Indicator lights	3-2		(for Switzerland only).....	5-4
	Speedometer.....	3-2		Tips for reducing fuel consumption	5-5
	Handlebar switches.....	3-2		Engine break-in	5-5
	Clutch lever	3-4		Parking.....	5-6
	Shift pedal	3-4	6	PERIODIC MAINTENANCE AND MINOR	
	Front brake lever	3-4		REPAIR.....	6-1
	Rear brake pedal.....	3-5		Tool kit.....	6-1
	Fuel tank cap.....	3-5		Periodic maintenance and lubrication chart	6-2
	Fuel	3-6		Panel removal and installation	6-5
	Fuel cock.....	3-6		Panels A and B	6-5
	Starter (choke) knob.....	3-7		Spark plug	6-6
	Seat.....	3-8		Engine oil	6-8
	Helmet holder.....	3-8		Air filter	6-10
	Rear shock absorber adjustment	3-9		Carburetor adjustment	6-11
	Sidestand	3-9		Idle speed adjustment.....	6-11
	Sidestand/clutch switch operation check	3-10			

TABLE OF CONTENTS

Throttle cable free play adjustment.....	6-12	Turn signal and tail/brake light bulb replacement.....	6-30
Cam chain adjustment.....	6-12	Front wheel removal.....	6-30
Valve clearance adjustment.....	6-13	Front wheel installation.....	6-31
Tires.....	6-13	Rear wheel removal.....	6-32
Wheels.....	6-15	Rear wheel installation.....	6-33
Clutch lever free play adjustment.....	6-16	Troubleshooting.....	6-33
Front brake lever free play adjustment.....	6-16	Troubleshooting chart.....	6-34
Rear brake pedal height and free play adjustment.....	6-17		
Brake light switch adjustment.....	6-18	7 MOTORCYCLE CARE AND STORAGE.....	7-1
Checking the front brake pads and rear brake shoes.....	6-19	Care.....	7-1
Inspecting the brake fluid level.....	6-20	Storage.....	7-4
Brake fluid replacement.....	6-20	8 SPECIFICATIONS.....	8-1
Drive chain slack check.....	6-21	Specifications.....	8-1
Drive chain slack adjustment.....	6-22	How to use the conversion table.....	8-5
Drive chain lubrication.....	6-23	9 CONSUMER INFORMATION.....	9-1
Cable inspection and lubrication.....	6-23	Identification number records.....	9-1
Throttle cable and grip lubrication.....	6-23	Key identification number.....	9-1
Brake and shift pedal lubrication.....	6-24	Vehicle identification number.....	9-1
Brake and clutch lever lubrication.....	6-24	Model label.....	9-2
Center and sidestand lubrication.....	6-24		
Front fork inspection.....	6-25		
Steering inspection.....	6-26		
Wheel bearings.....	6-26		
Battery.....	6-26		
Fuse replacement.....	6-28		
Headlight bulb replacement.....	6-29		

Motorcycles are fascinating vehicles, which can give you an unsurpassed feeling of power and freedom. However, they also impose certain limits, which you must accept; even the best motorcycle does not ignore the laws of physics.

Regular care and maintenance are essential for preserving your motorcycle's value and operating condition. Moreover, what is true for the motorcycle is also true for the rider: good performance depends on being in good shape. Riding under the influence of medication, drugs and alcohol is, of course, out of the question. Motorcycle riders - more than car drivers - must always be at their mental and physical best. Under the influence of even small amounts of alcohol, there is a tendency to take dangerous risks.

Protective clothing is as essential for the motorcycle rider as seat belts are for car drivers and passengers. Always wear a complete motorcycle suit (whether made of leather or tear-resistant synthetic materials with protectors), sturdy boots, motorcycle gloves and a properly fitting helmet. Optimum protective wear, however, should not encourage carelessness. Though full-coverage helmets and suits, in particular, create an illusion of total safety and protection, motorcyclists will always be vulnerable. Riders who lack critical self-control run the risk of going too fast and are apt to take chances. This is even more dangerous in wet weather. The good motorcyclist rides safely, predictably and defensively - avoiding all dangers, including those caused by others.

Enjoy your ride!

Left view

2

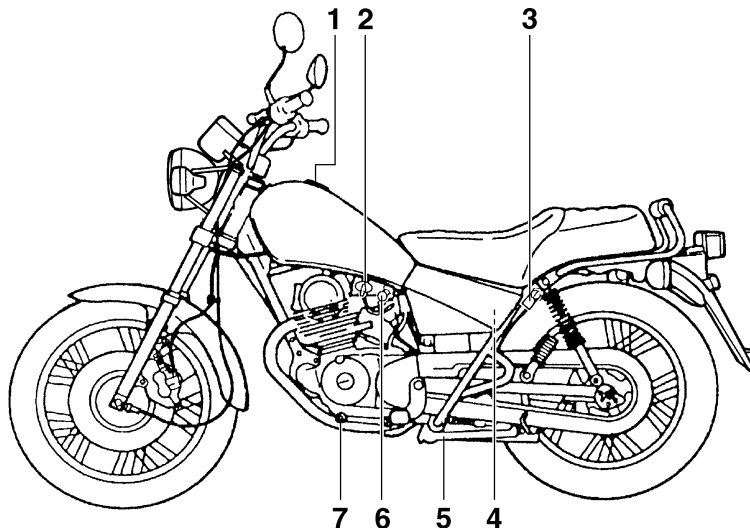

1. Fuel tank cap
2. Fuel cock
3. Helmet holder
4. Fuse box

(page 3-5)
(page 3-6)
(page 3-8)
(page 6-28)

5. Sidestand
6. Starter (choke) knob
7. Shift pedal

(page 3-9)
(page 3-7)
(page 3-4)

Right view

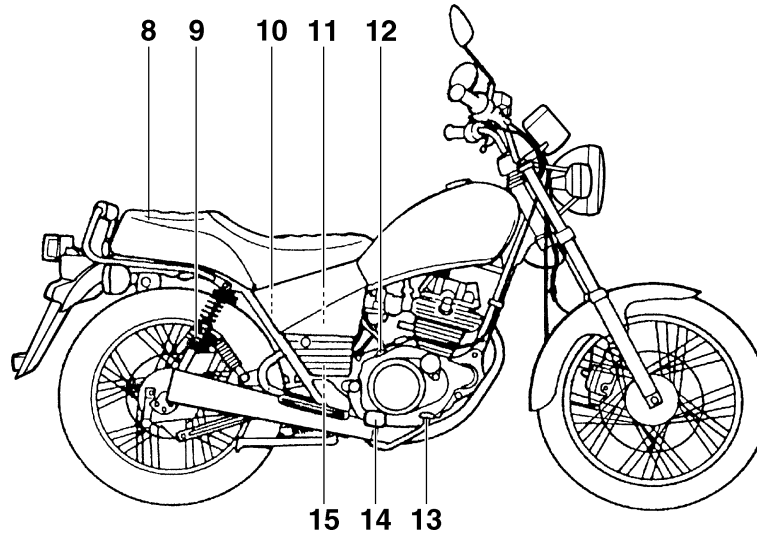

- | | | | |
|---|-------------|---------------------------|-------------|
| 8. Seat | (page 3-8) | 12. Engine oil filler cap | |
| 9. Rear shock absorber spring
preload adjusting ring | (page 3-9) | 13. Rear brake pedal | (page 3-5) |
| 10. Tool kit | (page 6-1) | 14. Footrest | |
| 11. Air filter | (page 6-10) | 15. Battery | (page 6-26) |

DESCRIPTION

Controls/Instruments

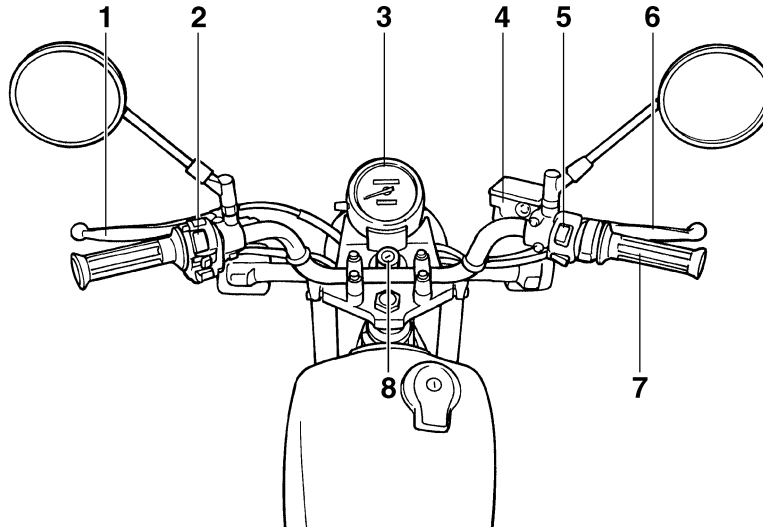

- 1. Clutch lever (page 3-4)
- 2. Left handlebar switches (page 3-2)
- 3. Speedometer (page 3-2)
- 4. Front brake fluid reservoir (page 6-20)

- 5. Right handlebar switches (page 3-3)
- 6. Front brake lever (page 3-4)
- 7. Throttle grip (page 6-12)
- 8. Main switch/steering lock (page 3-1)

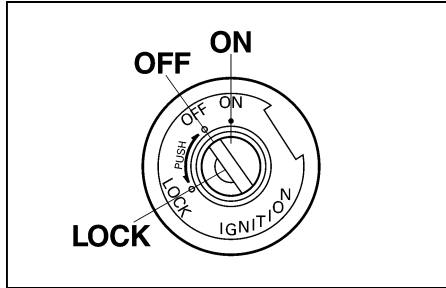

EAU00029*

Main switch/steering lock

The main switch controls the ignition and lighting systems. Its operation is described below.

ON

EAU00036

Electrical circuits are switched on. The engine can be started. The key cannot be removed in this position.

OFF

EAU00038

All electrical circuits are switched off. The key can be removed in this position.

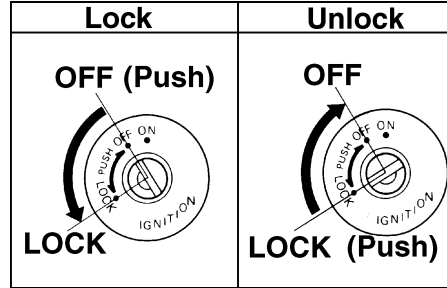

EAU00040

LOCK

The steering is locked in this position and all electrical circuits are switched off. The key can be removed in this position.

To lock the steering, turn the handlebars all the way to the left. While pushing the key into the main switch, turn it from "OFF" to "LOCK" and remove it. To release the lock, turn the key to "OFF" while pushing.

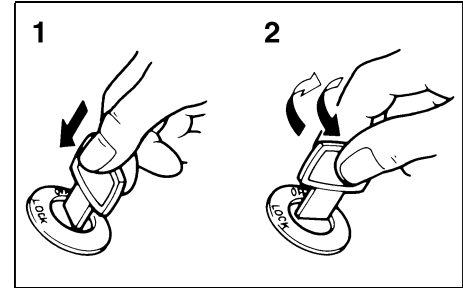

1. Push
2. Turn

3

EW000016

! WARNING

Never turn the key to "OFF" or "LOCK" when the motorcycle is moving. The electrical circuits will be switched off which may result in loss of control or an accident. Be sure the motorcycle is stopped before turning the key to "OFF" or "LOCK".

INSTRUMENT AND CONTROL FUNCTIONS

3

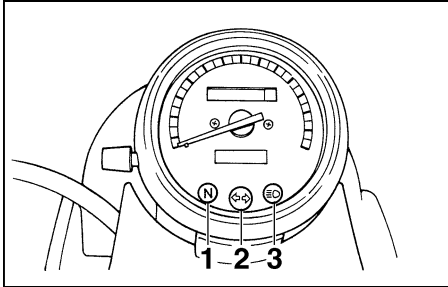

1. Neutral indicator light “N”
2. Turn indicator light “← →”
3. High beam indicator light “≡D”

EAU00056

Indicator lights

EAU00061

Neutral indicator light “N”

This indicator comes on when the transmission is in neutral.

EAU00057

Turn indicator light “← →”

This indicator flashes when the turn switch is moved to the left or right.

EAU00063

High beam indicator light “≡D”

This indicator comes on when the headlight high beam is used.

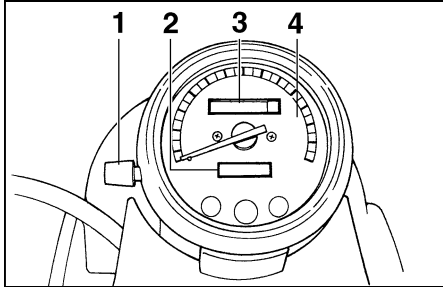

1. Reset knob
2. Tripmeter
3. Odometer
4. Speedometer

EAU00095*

Speedometer

The speedometer shows riding speed. This speedometer is equipped with an odometer and tripmeter. The tripmeter can be reset to “0” with the reset knob. Use the tripmeter to estimate how far you can ride on a tank of fuel. This information will enable you to plan fuel stops in the future.

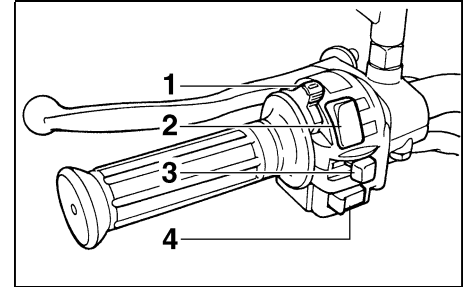

1. Lights switch
2. Dimmer switch
3. Turn signal switch
4. Horn switch “☹”

EAU00118

Handlebar switches

EAU00134

Lights switch

Turning the light switch to “≡D D≡”, turns on the auxiliary light, meter lights and taillight. Turning the light switch to “☼” turns the headlight on also.

EAU00121

Dimmer switch

Turn the switch to “≡D” for the high beam and to “≡D” for the low beam.

INSTRUMENT AND CONTROL FUNCTIONS

Turn signal switch

EAU00127

To signal a right-hand turn, push the switch to “↗”. To signal a left-hand turn, push the switch to “↖”. Once the switch is released it will return to the center position. To cancel the signal, push the switch in after it has returned to the center position.

Horn switch “🔊”

EAU00129

Press the switch to sound the horn.

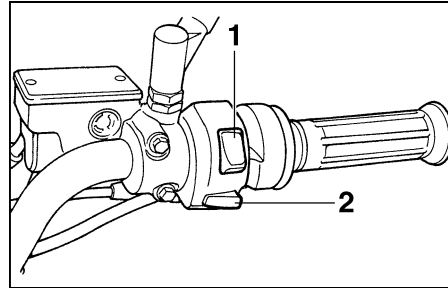

1. Engine stop switch
2. Start switch “🔊”

Engine stop switch

EAU00138

The engine stop switch is a safety device for use in an emergency such as when the motorcycle overturns or if trouble occurs in the throttle system. Turn the switch to “○” to start the engine. In case of emergency, turn the switch to “⊗” to stop the engine.

Start switch “🔊”

EAU00143

The starter motor cranks the engine when pushing the start switch.

EC000005

CAUTION:

See starting instructions prior to starting the engine.

INSTRUMENT AND CONTROL FUNCTIONS

3

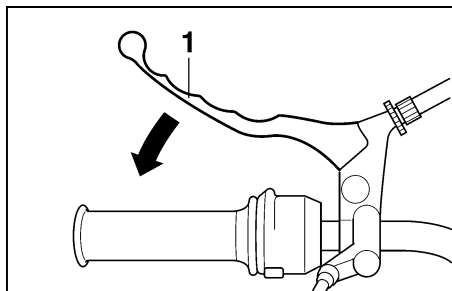

1. Clutch lever

EAU00152

Clutch lever

The clutch lever is located on the left handlebar, and the ignition circuit cut-off system is incorporated in the clutch lever holder. Pull the clutch lever to the handlebar to disengage the clutch, and release the lever to engage the clutch. The lever should be pulled rapidly and released slowly for smooth clutch operation. (Refer to the engine starting procedures for a description of the ignition circuit cut-off system.)

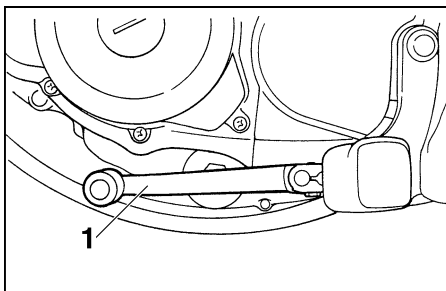

1. Shift pedal

EAU00157

Shift pedal

This motorcycle is equipped with a constant-mesh 5-speed transmission. The shift pedal is located on the left side of the engine and is used in combination with the clutch when shifting.

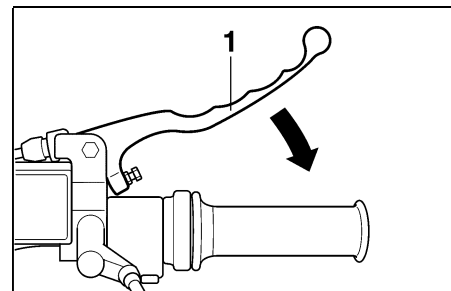

1. Front brake lever

EAU00158

Front brake lever

The front brake lever is located on the right handlebar. Pull it toward the handlebar to apply the front brake.

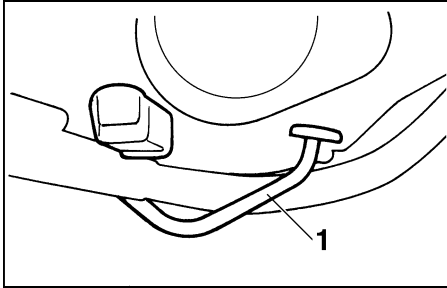

1. Rear brake pedal

EAU00162

Rear brake pedal

The rear brake pedal is on the right side of the motorcycle. Press down on the brake pedal to apply the rear brake.

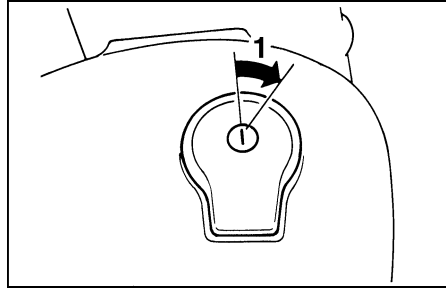

1. Open

EAU00167

Fuel tank cap

To open

Insert the key and turn it 1/4 turn clockwise. The lock will be released and the cap can be opened.

To close

Push the tank cap into position with the key inserted. To remove the key, turn it counterclockwise to the original position.

NOTE: _____
This tank cap cannot be closed unless the key is in the lock. The key cannot be removed if the cap is not locked properly.

EW000023

WARNING

Be sure the cap is properly installed and locked in place before riding the motorcycle.

INSTRUMENT AND CONTROL FUNCTIONS

3

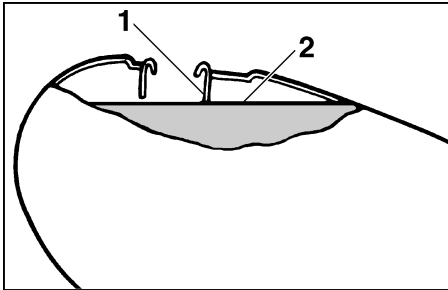

1. Filler tube
2. Fuel level

EAU001183

Fuel

Make sure there is sufficient fuel in the tank. Fill the fuel tank to the bottom of the filler tube as shown in the illustration.

EW000130

! WARNING

Do not overfill the fuel tank. Avoid spilling fuel on the hot engine. Do not fill the fuel tank above the bottom of the filler tube or it may overflow when the fuel heats up later and expands.

EAU00185

CAUTION:

Always wipe off spilled fuel immediately with a dry and clean soft cloth. Fuel may deteriorate painted surfaces or plastic parts.

EAU00191

Recommended fuel:

Regular unleaded gasoline with a research octane number of 91 or higher.

Fuel tank capacity:

Total:
10.0 L
Reserve:
1.6 L

NOTE:

If knocking or pinging occurs, use a different brand of gasoline or higher octane grade.

OFF: closed position

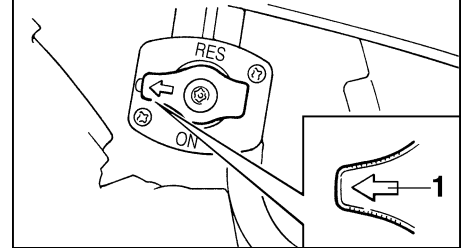

1. Arrow mark positioned over "OFF"

EAU03050

Fuel cock

The fuel cock supplies fuel from the tank to the carburetor while filtering it also.

The fuel cock has three positions:

OFF

With the lever in this position, fuel will not flow. Always return the lever to this position when the engine is not running.

INSTRUMENT AND CONTROL FUNCTIONS

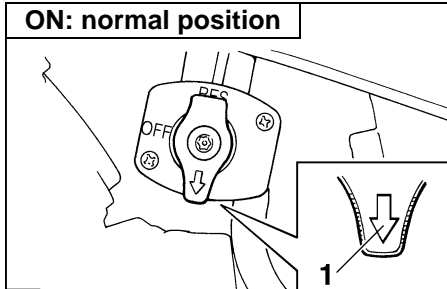

ON: normal position

1. Arrow mark positioned over "ON"

ON

With the lever in this position, fuel flows to the carburetor. Normal riding is done with the lever in this position.

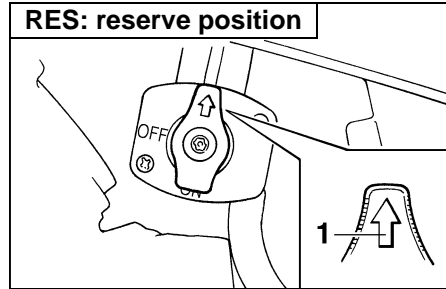

RES: reserve position

1. Arrow mark positioned over "RES"

RES

This indicates reserve. If you run out of fuel while riding, move the lever to this position. Fill the tank at the first opportunity. Be sure to set the lever back to "ON" after refueling!

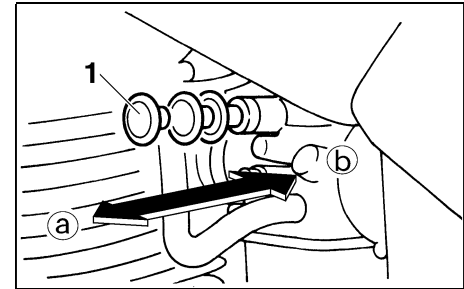

1. Starter (choke) knob

Starter (choke) knob

EAU03032

Starting a cold engine requires a richer air-fuel mixture, which is supplied by the starter (choke).

Move the knob in direction **a** to turn on the starter (choke).

Move the knob in direction **b** to turn off the starter (choke).

INSTRUMENT AND CONTROL FUNCTIONS

3

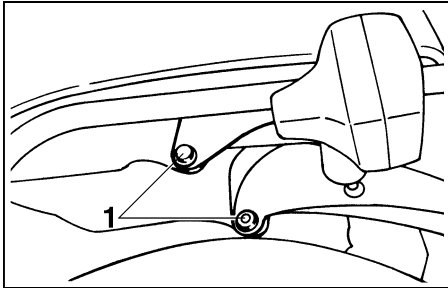

1. Bolt (× 2)

EAU01092

Seat

To remove the seat, remove the bolts.

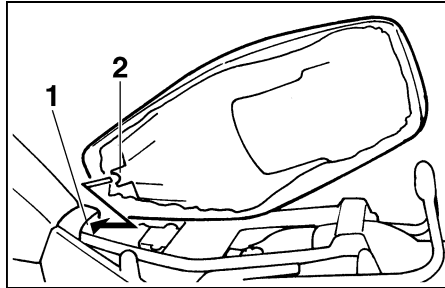

1. Seat holder
2. Projection

To install the seat, insert the projection on the front of the seat into the holder and push down on the seat, then tighten the bolts.

NOTE: _____
Make sure that the seat is securely fitted.

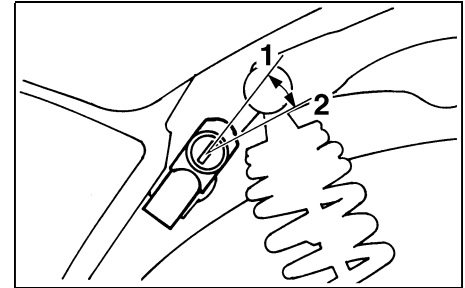

1. Lock
2. Open

EAU00261

Helmet holder

To open the helmet holder, insert the key in the lock and turn it as shown. To lock the helmet holder, turn the key to its original position.

EW000030

! WARNING

Never ride with a helmet in the helmet holder. The helmet may hit objects, causing loss of control and possibly an accident.

EW000040

EAU00330

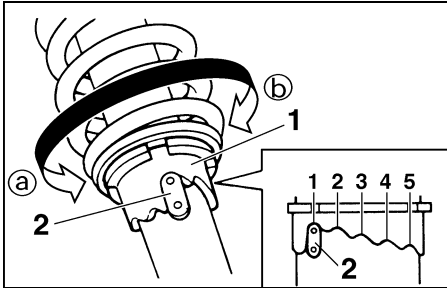

1. Spring preload adjusting ring
2. Position indicator

EAU00300

Rear shock absorber adjustment

Each shock absorber is equipped with a spring preload adjusting ring. Adjust spring preload as follows. Turn the adjusting ring in direction (a) to increase spring preload and in direction (b) to decrease spring preload. Make sure that the appropriate notch in the adjusting ring is aligned with the position indicator on the rear shock absorber.

	Soft/Standard				Hard
Adjusting position	1	2	3	4	5

⚠ WARNING

Always adjust each shock absorber to the same setting. Uneven adjustment can cause poor handling and loss of stability.

Sidestand

This model is equipped with an ignition circuit cut-off system. The motorcycle must not be ridden when the sidestand is down. The sidestand is located on the left side of the frame. (Refer to page 5-1 for an explanation of this system.)

3

EW000044

⚠ WARNING

This motorcycle must not be operated with the sidestand in the down position. If the stand is not properly retracted, it could contact the ground and distract the operator, resulting in a possible loss of control. Yamaha has designed into this motorcycle a lockout system to assist the operator in fulfilling the responsibility of retracting the sidestand. Please check carefully the operating instructions listed below and if there is any indication of a malfunction, return the motorcycle to a Yamaha dealer immediately for repair.

INSTRUMENT AND CONTROL FUNCTIONS

Sidestand/clutch switch operation check

EAU00332

Check the operation of the sidestand switch and clutch switch against the information below.

EW000046

WARNING

- Be sure to use the centerstand during this inspection.
- If improper operation is noted, consult a Yamaha dealer.

TURN MAIN SWITCH TO "ON" AND THE ENGINE STOP SWITCH TO "○".

TRANSMISSION IS IN GEAR AND SIDESTAND IS UP.

PULL IN CLUTCH LEVER AND PUSH START SWITCH.

ENGINE WILL START.

CLUTCH SWITCH IS OK.

SIDESTAND IS DOWN.

ENGINE WILL STALL.

SIDESTAND SWITCH IS OK.

Owners are personally responsible for their vehicle's condition. Your motorcycle's vital functions can start to deteriorate quickly and unexpectedly, even if it remains unused (for instance, if it is exposed to the elements). Any damage, fluid leak or loss of tire pressure could have serious consequences. Therefore, it is very important that, in addition to a thorough visual inspection, you check the following points before each ride.

EAU00340

PRE-OPERATION CHECK LIST

ITEM	CHECKS	PAGE
Front brake	<ul style="list-style-type: none"> • Check operation, free play, fluid level and fluid leakage. • Fill with DOT 4 (or DOT 3) brake fluid if necessary. 	6-16 ~ 6-20
Rear brake	<ul style="list-style-type: none"> • Check operation, condition and free play. • Adjust if necessary. 	
Clutch	<ul style="list-style-type: none"> • Check operation, condition and free play. • Adjust if necessary. 	6-16
Throttle grip and housing	<ul style="list-style-type: none"> • Check for smooth operation. • Lubricate if necessary. 	6-23
Engine oil	<ul style="list-style-type: none"> • Check oil level. • Fill with oil if necessary. 	6-8 ~ 6-9
Drive chain	<ul style="list-style-type: none"> • Check chain slack and condition. • Adjust if necessary. 	6-21 ~ 6-23
Wheels and tires	<ul style="list-style-type: none"> • Check tire pressure, wear, damage and spoke tightness. • Tighten spokes if necessary. 	6-13 ~ 6-15, 6-30 ~ 6-33
Control and meter cables	<ul style="list-style-type: none"> • Check for smooth operation. • Lubricate if necessary. 	6-23
Brake and shift pedal shafts	<ul style="list-style-type: none"> • Check for smooth operation. • Lubricate if necessary. 	6-24
Brake and clutch lever pivots	<ul style="list-style-type: none"> • Check for smooth operation. • Lubricate if necessary. 	6-24

PRE-OPERATION CHECKS

ITEM	CHECKS	PAGE
Center and sidestand pivot	<ul style="list-style-type: none">• Check for smooth operation.• Lubricate if necessary.	6-24
Chassis fasteners	<ul style="list-style-type: none">• Make sure that all nuts, bolts and screws are properly tightened.• Tighten if necessary.	—
Fuel	<ul style="list-style-type: none">• Check fuel level.• Fill with fuel if necessary.	3-5 ~ 3-6
Lights, signals and switches	<ul style="list-style-type: none">• Check for proper operation.	6-29 ~ 6-30
Battery	<ul style="list-style-type: none">• Check fluid level.• Fill with distilled water if necessary.	6-26 ~ 6-28

NOTE: _____
Pre-operation checks should be made each time the motorcycle is used. Such an inspection can be thoroughly accomplished in a very short time; and the added safety it assures is more than worth the time involved.

 **WARNING**

If any item in the PRE-OPERATION CHECK is not working properly, have it inspected and repaired before operating the motorcycle.

EAU00373

EAU03011

EW000054

! WARNING

- Before riding this motorcycle, become thoroughly familiar with all operating controls and their functions. Consult a Yamaha dealer regarding any control or function that you do not thoroughly understand.
- Never start your engine or let it run for any length of time in a closed area. The exhaust fumes are poisonous and can cause loss of consciousness and death within a short time. Always operate your motorcycle in an area with adequate ventilation.
- Before starting out, always be sure the sidestand is up. Failure to retract the sidestand completely can result in a serious accident when you try to turn a corner.

Starting the engine

NOTE:

This motorcycle is equipped with an ignition circuit cut-off system. The engine can be started only under one of the following conditions:

- The transmission is in neutral.
- The sidestand is up, the transmission is in gear and the clutch is disengaged.

The motorcycle must not be ridden when the sidestand is down.

! WARNING

Before going through the following steps, check the function of the sidestand switch and clutch switch. (Refer to page 3-10.)

OPERATION AND IMPORTANT RIDING POINTS

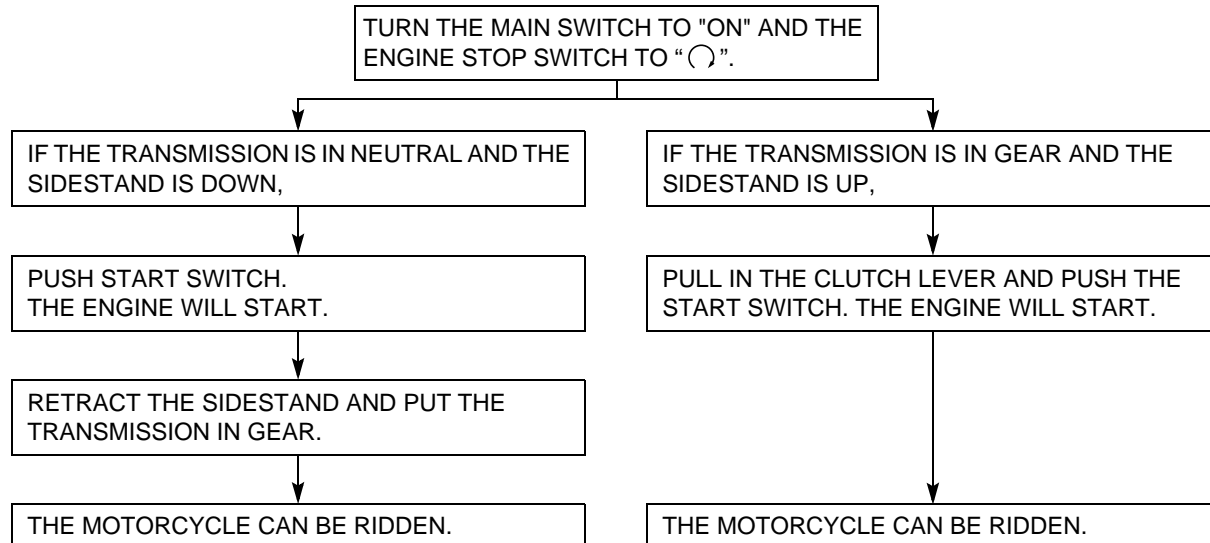

5

OPERATION AND IMPORTANT RIDING POINTS

1. Turn the fuel cock to “ON”.
2. Turn the main switch to “ON” and the engine stop switch to “○”.
3. Shift the transmission into neutral.

NOTE: _____

When the transmission is in neutral, the neutral indicator light should be on. If the light does not come on, ask a Yamaha dealer to inspect it.

4. Turn on the starter (choke) and completely close the throttle grip.
5. Start the engine by pushing the start switch.

NOTE: _____

If the engine fails to start, release the start switch, wait a few seconds, then try again. Each attempt should be as short as possible to preserve the battery. Do not crank the engine more than 10 seconds on any one attempt.

6. After starting the engine, move the starter (choke) to the halfway position.

NOTE: _____

For maximum engine life, never accelerate hard with a cold engine!

7. After warming up the engine, turn off the starter (choke) completely.

NOTE: _____

The engine is warm when it responds normally to the throttle with the starter (choke) turned off.

EAU01258

Starting a warm engine

The starter (choke) is not required when the engine is warm.

EC000046

CAUTION: _____

See the “Engine break-in” section prior to operating the motorcycle for the first time.

OPERATION AND IMPORTANT RIDING POINTS

EC000048

EAU02941

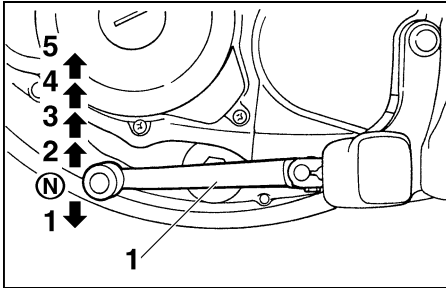

1. Shift pedal
N. Neutral

EAU00423

5

Shifting

The transmission lets you control the amount of power you have available at a given speed for starting, accelerating, climbing hills, etc. The use of the shift pedal is shown in the illustration.

To shift into neutral, depress the shift pedal repeatedly until it reaches the end of its travel, then raise the pedal slightly.

CAUTION:

- Do not coast for long periods with the engine off, and do not tow the motorcycle a long distance. Even with gears in neutral, the transmission is only properly lubricated when the engine is running. Inadequate lubrication may damage the transmission.
- Always use the clutch when changing gears. The engine, transmission, and driveline are not designed to withstand the shock of forced shifting and can be damaged by shifting without using the clutch.

Recommended shift points (for Switzerland only)

The recommended shift points are shown in the table below.

	Acceleration shift point (km/h)
1st → 2nd	23
2nd → 3rd	36
3rd → 4th	50
4th → 5th	60

NOTE:

When shifting two gears down from 4th to 2nd, bring your motorcycle to a speed of 35 km/h.

EAU00424

Tips for reducing fuel consumption

Your motorcycle's fuel consumption depends to a large extent on your riding style. The following tips can help reduce fuel consumption:

- Warm up the engine before riding.
- Turn off the starter (choke) as soon as possible.
- Shift up swiftly and avoid high engine speeds during acceleration.
- Do not double-clutch or rev the engine while shifting down and avoid high engine speeds with no load on the engine.
- Turn off the engine instead of letting it idle for an extended length of time, i.e. in traffic jams, at traffic lights or railroad crossings.

EAU00436

Engine break-in

There is never a more important period in the life of your motorcycle than the period between zero and 1,000 km. For this reason we ask that you carefully read the following material. Because the engine is brand new, you must not put an excessive load on it for the first 1,000 km. The various parts in the engine wear and polish themselves to the correct operating clearances. During this period, prolonged full throttle operation, or any condition which might result in excessive heating of the engine, must be avoided.

OPERATION AND IMPORTANT RIDING POINTS

0 ~ 150 km

EAU00438

Avoid operation above 1/3 throttle. Stop the engine and let it cool for 5 to 10 minutes after every hour of operation. Vary the speed of the motorcycle from time to time. Do not operate it at one set throttle position.

150 ~ 500 km

Avoid prolonged operation above 1/2 throttle.

500 ~ 1,000 km

Avoid cruising speeds in excess of 3/4 throttle.

EC000050

CAUTION: _____

After 1,000 km of operation, be sure to replace the engine oil.

1,000 km and beyond

Avoid prolonged full-throttle operation. Vary speed occasionally.

EC000049

CAUTION: _____

If any engine trouble should occur during the break-in period, consult a Yamaha dealer immediately.

EAU00457

Parking

When parking the motorcycle, stop the engine and remove the ignition key. Turn the fuel cock to "OFF" whenever stopping the engine.

EW000058

! WARNING _____

The exhaust system is hot. Park the motorcycle in a place where pedestrians or children are not likely to touch the motorcycle. Do not park the motorcycle on a slope or soft ground; the motorcycle may overturn.

EAU00464

Periodic inspection, adjustment and lubrication will keep your motorcycle in the safest and most efficient condition possible. Safety is an obligation of the motorcycle owner. The maintenance and lubrication schedule chart should be considered strictly as a guide to general maintenance and lubrication intervals. YOU MUST TAKE INTO CONSIDERATION THAT WEATHER, TERRAIN, GEOGRAPHICAL LOCATIONS, AND A VARIETY OF INDIVIDUAL USES ALL TEND TO DEMAND THAT EACH OWNER ALTER THIS TIME SCHEDULE TO SHORTER INTERVALS TO MATCH THE ENVIRONMENT. The most important points of motorcycle inspection, adjustment, and lubrication are explained in the following pages.

EW000060

! WARNING

If you are not familiar with motorcycle service, this work should be done by a Yamaha dealer.

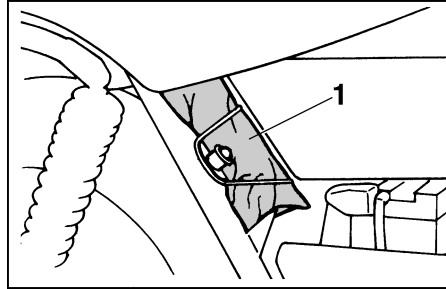

1. Tool kit

EAU01175

Tool kit

The tool kit is located behind panel A. (See page 6-5 for panel removal and installation procedures.) The tools provided in the owner's tool kit are to assist you in the performance of periodic maintenance. However, some other tools such as a torque wrench are also necessary to perform the maintenance correctly.

The service information included in this manual is intended to provide you, the owner, with the necessary information for completing some of your own preventive maintenance and minor repairs.

NOTE:

If you do not have necessary tools required during a service operation, take your motorcycle to a Yamaha dealer for service.

EW000063

! WARNING

Modifications to this motorcycle not approved by Yamaha may cause loss of performance, and render it unsafe for use. Consult a Yamaha dealer before attempting any changes.

PERIODIC MAINTENANCE AND MINOR REPAIR

EAU03686

Periodic maintenance and lubrication chart

NOTE:

- The annual checks must be performed every year, except if a kilometer-based maintenance is performed instead.
- From 30,000 km, repeat the maintenance intervals starting from 6,000 km.
- Items marked with an asterisk should be performed by a Yamaha dealer as they require special tools, data and technical skills.

NO.	ITEM	CHECK OR MAINTENANCE JOB	ODOMETER READING ($\times 1,000$ km)					ANNUAL CHECK
			1	6	12	18	24	
1	* Fuel line	• Check fuel hoses for cracks or damage.		√	√	√	√	√
2	Spark plug	• Check condition. • Clean and regap.		√		√		
		• Replace.			√		√	
3	* Valves	• Check valve clearance. • Adjust.		√	√	√	√	
4	* Timing chain	• Check chain tension. • Adjust.		√	√	√	√	
5	Air filter element	• Clean.		√		√		
		• Replace.			√		√	
6	* Battery	• Check electrolyte level and specific gravity. • Make sure that the breather hose is properly routed.		√	√	√	√	√
7	Clutch	• Check operation. • Adjust.	√	√	√	√	√	
8	* Front brake	• Check operation, fluid level and vehicle for fluid leakage. (See NOTE on page 6-4.)	√	√	√	√	√	√
		• Replace brake pads.	Whenever worn to the limit					
9	* Rear brake	• Check operation and adjust brake pedal free play.	√	√	√	√	√	√
		• Replace brake shoes.	Whenever worn to the limit					

PERIODIC MAINTENANCE AND MINOR REPAIR

NO.	ITEM	CHECK OR MAINTENANCE JOB	ODOMETER READING (× 1,000 km)					ANNUAL CHECK
			1	6	12	18	24	
10	* Wheels	<ul style="list-style-type: none"> • Check runout, spoke tightness and for damage. • Tighten spokes if necessary. 		√	√	√	√	
11	* Tires	<ul style="list-style-type: none"> • Check tread depth and for damage. • Replace if necessary. • Check air pressure. • Correct if necessary. 		√	√	√	√	
12	* Wheel bearings	<ul style="list-style-type: none"> • Check bearing for looseness or damage. 		√	√	√	√	
13	* Swingarm	<ul style="list-style-type: none"> • Check operation and for excessive play. 		√	√	√	√	
14	Drive chain	<ul style="list-style-type: none"> • Check chain slack. • Make sure that the rear wheel is properly aligned. • Clean and lubricate. 	Every 1,000 km and after washing the motorcycle or riding in the rain.					
15	* Steering bearings	<ul style="list-style-type: none"> • Check bearing play and steering for roughness. • Lubricate with lithium-soap-based grease. 	√	√	√	√	√	
16	* Chassis fasteners	<ul style="list-style-type: none"> • Make sure that all nuts, bolts and screws are properly tightened. 		√	√	√	√	√
17	Sidestand, centerstand	<ul style="list-style-type: none"> • Check operation. • Lubricate. 		√	√	√	√	√
18	* Sidestand switch	<ul style="list-style-type: none"> • Check operation. 	√	√	√	√	√	√
19	* Front fork	<ul style="list-style-type: none"> • Check operation and for oil leakage. 		√	√	√	√	
20	* Shock absorber assemblies	<ul style="list-style-type: none"> • Check operation and shock absorbers for oil leakage. 		√	√	√	√	
21	* Carburetor	<ul style="list-style-type: none"> • Check starter (choke) operation. • Adjust engine idling speed. 	√	√	√	√	√	√
22	Engine oil	<ul style="list-style-type: none"> • Change. 	√	√	√	√	√	√
23	Engine oil filter element	<ul style="list-style-type: none"> • Clean. 	√		√		√	
24	* Front and rear brake switches	<ul style="list-style-type: none"> • Check operation. 	√	√	√	√	√	√
25	Moving parts and cables	<ul style="list-style-type: none"> • Lubricate. 		√	√	√	√	√

PERIODIC MAINTENANCE AND MINOR REPAIR

NO.	ITEM	CHECK OR MAINTENANCE JOB	ODOMETER READING ($\times 1,000$ km)					ANNUAL CHECK
			1	6	12	18	24	
26	* Lights, signals and switches	<ul style="list-style-type: none"> • Check operation. • Adjust headlight beam. 	√	√	√	√	√	√

EAU03541

NOTE:

- The air filter needs more frequent service if you are riding in unusually wet or dusty areas.
- Hydraulic brake service
 - Regularly check and, if necessary, correct the brake fluid level.
 - Every two years replace the internal components of the brake master cylinder and caliper, and change the brake fluid.
 - Replace the brake hoses every four years and if cracked or damaged.

PERIODIC MAINTENANCE AND MINOR REPAIR

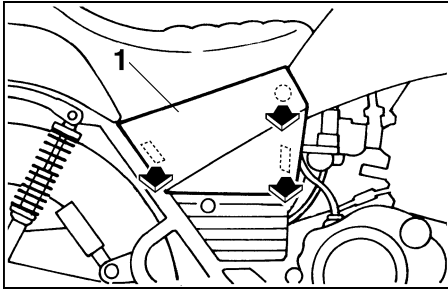

1. Panel A

EAU01122

Panel removal and installation

The panels illustrated need to be removed to perform some of the maintenance described in this chapter. Refer to this section each time a panel has to be removed or reinstalled.

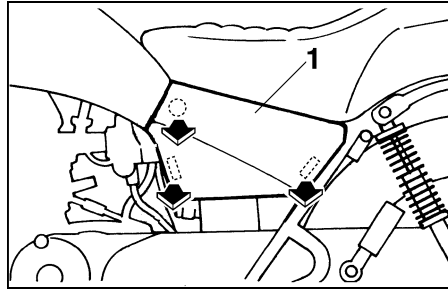

1. Panel B

EAU00494*

Panels A and B

To remove

Pull outward on the areas shown.

To install

Place the panel in its original position.

PERIODIC MAINTENANCE AND MINOR REPAIR

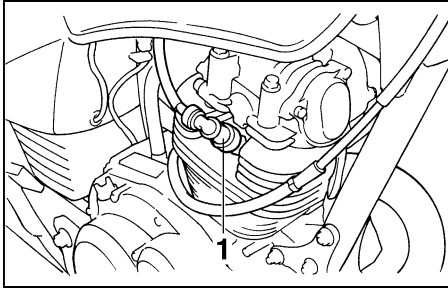

1. Spark plug cap

EAU01833

Spark plug Removal

1. Remove the spark plug cap.

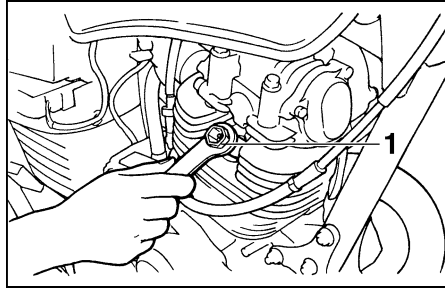

1. Spark plug wrench
2. Use the spark plug wrench in the tool kit to remove the spark plug as shown.

Inspection

The spark plug is an important engine component and is easy to inspect. The condition of the spark plug can indicate the condition of the engine.

The ideal color on the white insulator around the center electrode is a medium-to-light tan color for a motorcycle that is being ridden normally.

Do not attempt to diagnose such problems yourself. Instead, take the motorcycle to a Yamaha dealer. You should periodically remove and inspect the

spark plug because heat and deposits will cause any spark plug to slowly break down and erode. If electrode erosion becomes excessive, or if carbon and other deposits are excessive, you should replace the spark plug with the specified plug.

Specified spark plug:
DR8EA (NGK)

PERIODIC MAINTENANCE AND MINOR REPAIR

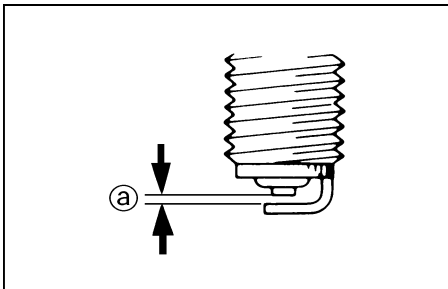

a. Spark plug gap

Tightening torque:
Spark plug:
17.5 Nm (1.75 m·kg)

NOTE: _____
If a torque wrench is not available when you are installing a spark plug, a good estimate of the correct torque is 1/4 to 1/2 turn past finger tight. Have the spark plug tightened to the specified torque as soon as possible.

Installation

1. Measure the electrode gap with a wire thickness gauge and, if necessary, adjust the gap to specification.

Spark plug gap:
0.6 ~ 0.7 mm

2. Clean the gasket surface. Wipe off any grime from the threads.
3. Install the spark plug and tighten it to the specified torque.

4. Install the spark plug cap.

PERIODIC MAINTENANCE AND MINOR REPAIR

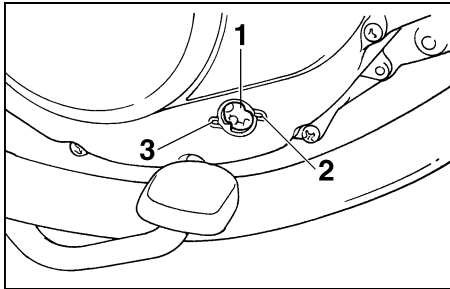

1. Oil level window
2. Maximum level mark
3. Minimum level mark

EAU01093*

Engine oil

Oil level inspection

1. Place the motorcycle on the centerstand. Warm up the engine for several minutes.

NOTE:

Be sure the motorcycle is positioned straight up when checking the oil level. A slight tilt toward the side can result in false readings.

2. With the engine stopped, check the oil level through the level window located at the lower part of the right side crankcase cover.

NOTE:

Wait a few minutes until the oil level settles before checking.

3. The oil level should be between the maximum level and minimum level marks. If the level is low, fill the engine with sufficient oil to raise it to the specified level.

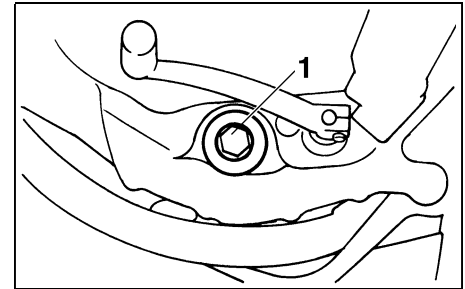

1. Engine oil drain bolt A

Engine oil replacement and oil filter element cleaning

1. Warm up the engine for a few minutes.
2. Stop the engine. Place an oil pan under the engine and remove the oil filler cap.
3. Remove the drain bolt and drain the oil.

EC000070*

CAUTION:

When removing the oil drain bolt, the O-ring, compression spring, and oil strainer will fall out. Take care not to lose these parts.

PERIODIC MAINTENANCE AND MINOR REPAIR

EC000071*

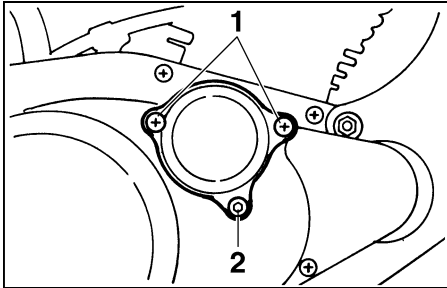

1. Filter cover screw (× 2)
2. Engine oil drain bolt B

4. Remove the filter cover screws, drain bolt and the oil filter cover and oil filter.
5. Clean the oil filter and strainer with solvent. Replace if necessary.
6. Check the O-rings. If damaged, replace it.
7. Install the drain bolt, filter cover screws and drain bolt. Then tighten to the specified torque.

NOTE: _____
Make sure the O-ring is seated properly.

CAUTION: _____

Before reinstalling the oil drain bolt, do not forget to install the O-ring, compression spring, and oil strainer in position.

Tightening torque:

- Drain bolt A:
43 Nm (4.3 m·kg)
- Filter cover screw:
7 Nm (0.7 m·kg)
- Drain bolt B:
10 Nm (1.0 m·kg)

8. Fill engine with oil. Install the oil filler cap and tighten.

Recommended oil:

See page 8-1.

Oil quantity:

Total amount:

1.3 L

Periodic oil change:

1.0 L

With oil filter replacement:

1.1 L

EC000066

CAUTION: _____

- Do not put in any chemical additives. Engine oil also lubricates the clutch and additives could cause clutch slippage.
- Be sure no foreign material enters the crankcase.

9. Start the engine and warm up for a few minutes. While warming up, check for oil leakage. If oil leakage is found, stop the engine immediately and check for the cause.
10. Stop the engine and check the oil level.

PERIODIC MAINTENANCE AND MINOR REPAIR

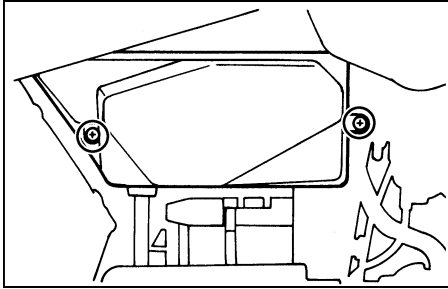

EAU01094

Air filter

The air filter should be cleaned at the specified intervals. It should be cleaned more frequently if you are riding in unusually wet or dusty areas.

1. Remove panel A. (See page 6-5 for panel removal and installation procedures.)
2. Remove the air filter case fitting screws and the air filter case cover.
3. Remove the air filter from its case and clean it with solvent. After cleaning, remove the remaining solvent by squeezing the air filter.

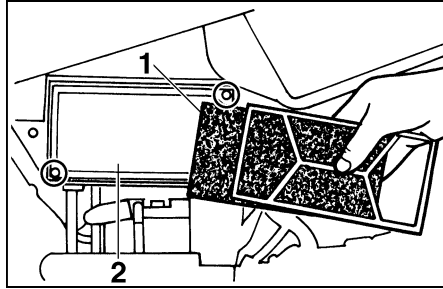

1. Air filter
2. Steel net

4. Apply the recommended oil to the entire surface of the filter and squeeze out the excess oil. It should be wet but not dripping.

Recommended oil:
Same as engine oil

5. Install the air filter in its case.
6. Install panel A.

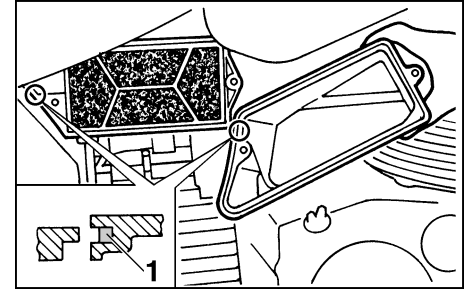

1. Rubber gasket

EC000085

CAUTION:

- Make sure the air filter is properly seated in the filter case.
- The engine should never be run without the air filter installed. Excessive piston and/or cylinder wear may result.

PERIODIC MAINTENANCE AND MINOR REPAIR

Carburetor adjustment

EAU00629

The carburetor is a vital part of the engine and requires very sophisticated adjustment. Most adjustments should be left to a Yamaha dealer who has the professional knowledge and experience to do so. However, the following may be serviced by the owner as part of routine maintenance.

EC000094

CAUTION:

The carburetor was set at the Yamaha factory after many tests. If the settings are changed, poor engine performance and damage may result.

Idle speed adjustment

EAU01168

NOTE:

A diagnostic tachometer must be used for this procedure.

1. Attach the tachometer. Start the engine and warm it up for a few minutes at approximately 1,000 to 2,000 r/min. Occasionally rev the engine to 4,000 to 5,000 r/min. The engine is warm when it quickly responds to the throttle.

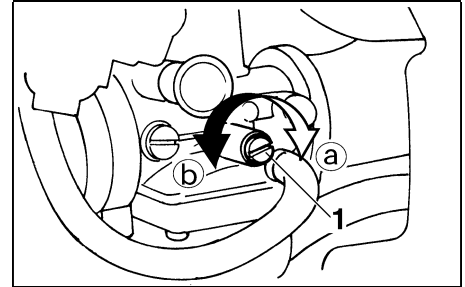

1. Throttle stop screw

2. Set the idle to the specified engine speed by adjusting the throttle stop screw. Turn the screw in direction (a) to increase engine speed and in direction (b) to decrease engine speed.

Standard idle speed:
1,300 ~ 1,400 r/min

NOTE:

If the specified idle speed cannot be obtained by performing the above adjustment, consult a Yamaha dealer.

PERIODIC MAINTENANCE AND MINOR REPAIR

EAU00636

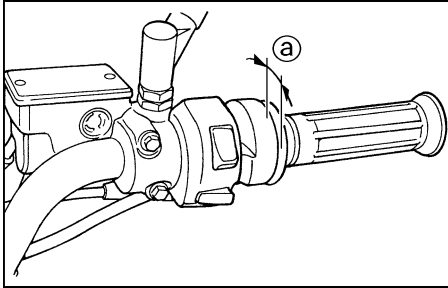

a. Free play

EAU00634

Throttle cable free play adjustment

NOTE: Before checking the throttle cable free play, the engine idling speed should be adjusted.

Adjust the throttle cable by turning the adjusting nut so that specified free play at the throttle grip is obtained.

Free play:
3 ~ 5 mm

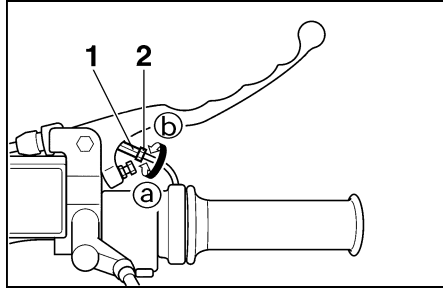

1. Adjusting nut
2. Locknut

1. Loosen the locknut.
2. Turn the adjusting nut in direction ① to increase free play and in direction ② to decrease free play.
3. Tighten the locknut.

Cam chain adjustment

The cam chain becomes loose with use, resulting in improper valve timing and engine noise. To prevent this, the cam chain tensioner must be adjusted regularly. This adjustment, however, should be left to a professional Yamaha service technician.

PERIODIC MAINTENANCE AND MINOR REPAIR

Valve clearance adjustment

EAU00637

The correct valve clearance changes with use, resulting in improper fuel/air supply or engine noise. To prevent this, the valve clearance must be adjusted regularly. This adjustment however, should be left to a professional Yamaha service technician.

Tires

To ensure maximum performance, long service, and safe operation, note the following:

Tire air pressure

Always check and adjust the tire pressure before operating the motorcycle.

EAU00647

Maximum load*	160 kg	
	Front	Rear
Cold tire pressure		
Up to 90 kg*	175 kPa (1.75 kg/cm ² , 1.75 bar)	200 kPa (2.00 kg/cm ² , 2.00 bar)
90 kg load ~ Maximum load*	175 kPa (1.75 kg/cm ² , 1.75 bar)	225 kPa (2.25 kg/cm ² , 2.25 bar)

* Load is the total weight of cargo, rider, passenger and accessories.

WARNING

Tire inflation pressure should be checked and adjusted when the temperature of the tire equals the ambient air temperature. Tire inflation pressure must be adjusted according to total weight of cargo, rider, passenger, and accessories (fairing, saddlebags, etc. if approved for this model), and vehicle speed.

EW000082

PERIODIC MAINTENANCE AND MINOR REPAIR

EW000083

⚠ WARNING

Proper loading of your motorcycle is important for several characteristics of your motorcycle, such as handling, braking, performance and safety. Do not carry loosely packed items that can shift. Securely pack your heaviest items close to the center of the motorcycle, and distribute the weight evenly from side to side. Properly adjust the suspension for your load, and check the condition and pressure of your tires. **NEVER OVERLOAD YOUR MOTORCYCLE.** Make sure the total weight of the cargo, rider, passenger, and accessories (fairing, saddlebags, etc. if approved for this model) does not exceed the maximum load of the motorcycle. Operation of an overloaded motorcycle could cause tire damage, an accident, or even injury.

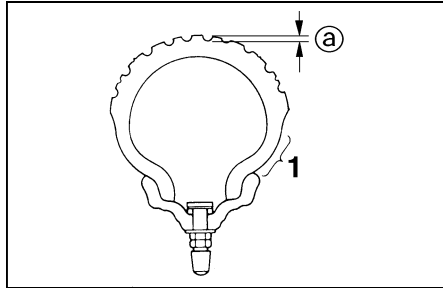

- 1. Side wall
- a. Tread depth

Minimum tire tread depth (front and rear)	1.6 mm
---	--------

NOTE:

These limits may be different by regulation from country to country. If so, conform to the limits specified by the regulations of your own country.

Tire inspection

Always check the tires before operating the motorcycle. If center tread depth reaches the limit as shown, if the tire has a nail or glass fragments in it, or if the side wall is cracked, contact a Yamaha dealer immediately and have the tire replaced.

FRONT

Manufacturer	Size	Type
Inoue	3.00-17 45P	8F

REAR

Manufacturer	Size	Type
Inoue	3.50-16 52P	8RA

EAU00681

EAU00685

WARNING

- **Operating the motorcycle with excessively worn tires decrease riding stability and can lead to loss of control. Have excessively worn tires replaced by a Yamaha dealer immediately. Brakes, tires, and related wheel parts replacement should be left to a Yamaha Service Technician.**
- **Patching a punctured tube is not recommended. If it is absolutely necessary to do so, use great care and replace the tube as soon as possible with a good quality replacement.**

Wheels

To ensure maximum performance, long service, and safe operation, note the following:

- Always inspect the wheels before a ride. Check for cracks, bends or warpage of the wheel. Be sure the spokes are tight and undamaged. If any abnormal condition exists in a wheel, consult a Yamaha dealer. Do not attempt even small repairs to the wheel. If a wheel is deformed or cracked, it must be replaced.
- Tires and wheels should be balanced whenever either one is changed or replaced. Failure to have a wheel balanced can result in poor performance, adverse handling characteristics, and shortened tire life.
- Ride at moderate speeds after changing a tire since the tire surface must first be broken in for it to develop its optimal characteristics.

PERIODIC MAINTENANCE AND MINOR REPAIR

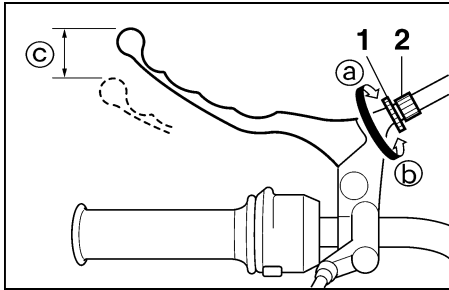

1. Locknut
2. Adjusting bolt
- c. Free play

EAU00692

Clutch lever free play adjustment

The clutch lever free play should be adjusted to 10 ~ 15 mm. If the free play is incorrect, adjust as follows.

1. Loosen the locknut.
2. Turn the adjusting bolt at the clutch lever in direction (a) to increase free play or in direction (b) to decrease free play.
3. Tighten the locknut.

NOTE:

If proper adjustment cannot be obtained or the clutch does not work correctly, ask a Yamaha dealer to inspect the internal clutch mechanism.

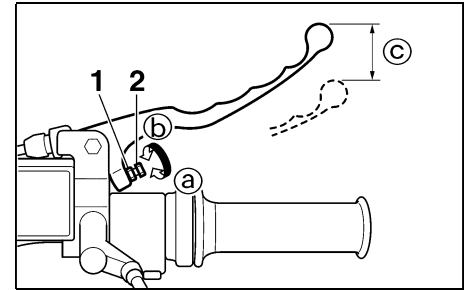

1. Locknut
2. Adjusting bolt
- c. Free play

EAU00696

Front brake lever free play adjustment

The free play at the front brake lever should be 2 ~ 5 mm.

1. Loosen the locknut.
2. Turn the adjusting bolt in direction (a) to increase free play or in direction (b) to decrease free play.
3. After adjusting, tighten the locknut.

PERIODIC MAINTENANCE AND MINOR REPAIR

EW000099

! WARNING

- Check the brake lever free play. Be sure the brake is working properly.
- A soft or spongy feeling in the brake lever can indicate the presence of air in the brake system. This air must be removed by bleeding the brake system before the motorcycle is operated. Air in the system will cause greatly diminished braking capability and can result in loss of control and an accident. Have a Yamaha dealer inspect and bleed the system if necessary.

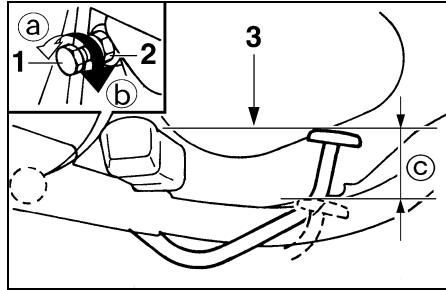

1. Adjusting bolt (for pedal height)
2. Locknut
3. Pedal height
- c. Free play

EAU01105

Rear brake pedal height and free play adjustment

EW000104

! WARNING

It is advisable to have a Yamaha dealer make this adjustment.

Pedal height

The pedal height should be adjusted so that the top of brake pedal is aligned with the top of footrest.

1. Loosen the locknut.
2. Turn the adjusting bolt in direction ① to raise the brake pedal or in direction ② to lower the brake pedal.
3. Tighten the locknut.

EW000105

! WARNING

After adjusting the pedal height, adjust brake pedal free play.

PERIODIC MAINTENANCE AND MINOR REPAIR

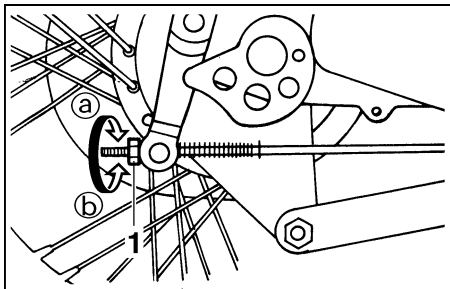

1. Adjusting nut

Free play

The free play at the end of the brake pedal should be approximately 20 ~ 30 mm. Turn the adjusting nut in direction ① to increase the brake pedal free play or in direction ② to reduce the brake pedal free play.

EW000103

WARNING

Check the operation of the brake light after adjusting the rear brake.

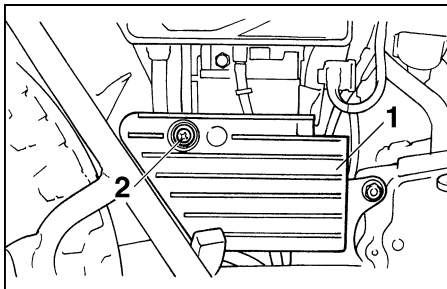

1. Battery cover
2. Screw

Brake light switch adjustment

EAU01646

The rear brake light switch is activated by the brake pedal and is properly adjusted when the brake light comes on just before braking takes effect. Adjust the brake light switch as follows.

1. Remove panel A.
2. Remove the battery cover by removing the screw.

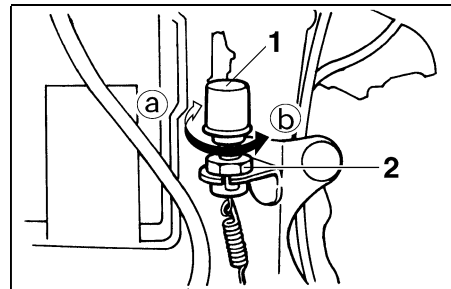

1. Brake light switch
2. Adjusting nut

3. Hold the switch body so it does not rotate while turning the adjusting nut.
4. Turn the adjusting nut in direction ① to make the brake light come on earlier. Turn the adjusting nut in direction ② to make the brake light come on later.

PERIODIC MAINTENANCE AND MINOR REPAIR

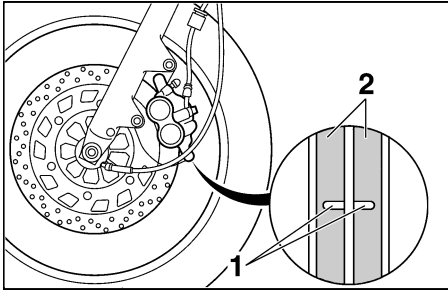

1. Wear indicator groove (× 2)
2. Brake pads

EAU00720

Checking the front brake pads and rear brake shoes

EAU01119

Front brake

Wear indicator grooves are provided on each brake pad. These indicators allow checking of brake pad wear without disassembling the brake. Inspect the grooves. If they have almost disappeared, ask a Yamaha dealer to replace the pads.

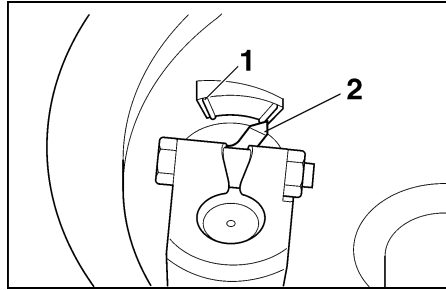

1. Wear limit
2. Wear indicator

EAU00727

Rear brake

Apply the brake and inspect the wear indicator.

If the indicator reaches the wear limit line, ask a Yamaha dealer to replace the shoes.

PERIODIC MAINTENANCE AND MINOR REPAIR

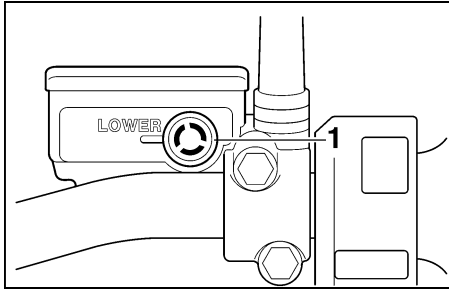

1. Minimum level mark

EAU00732

Inspecting the brake fluid level

Insufficient brake fluid may let air enter the brake system, possibly causing the brakes to become ineffective.

Before riding, check that the brake fluid is above the minimum level and fill when necessary.

Observe these precautions:

- When checking the fluid level, make sure the top of the master cylinder is level by turning the handlebars.

- Use only the designated quality brake fluid. Otherwise, the rubber seals may deteriorate, causing leakage and poor brake performance.

Recommended brake fluid: DOT 4

NOTE:

If DOT 4 is not available, DOT 3 can be used.

- Refill with the same type of brake fluid. Mixing fluids may result in a harmful chemical reaction and lead to poor brake performance.
- Be careful that water does not enter the master cylinder when refilling. Water will significantly lower the boiling point of the fluid and may result in vapor lock.
- Brake fluid may deteriorate painted surfaces or plastic parts. Always clean up spilled fluid immediately.
- Have a Yamaha dealer check the cause if the brake fluid level goes down.

EAU00742

Brake fluid replacement

The brake fluid should be replaced only by trained Yamaha service personnel. Have the Yamaha dealer replace the following components during periodic maintenance or when they are damaged or leaking:

- oil seals (every two years)
- brake hoses (every four years)

PERIODIC MAINTENANCE AND MINOR REPAIR

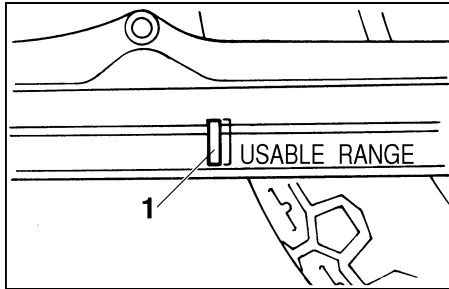

1. Inspection window

EAU00746

Drive chain slack check

NOTE:

Spin the wheel several times and find the tightest position of the chain. Check and/or adjust the chain slack while it's in this tightest position.

The chain slack should be checked through the inspection window in the chain case by the following procedure.

1. Place the motorcycle on the centerstand.
2. Put the transmission in neutral.
3. While looking in the inspection window, rotate the rear wheel.

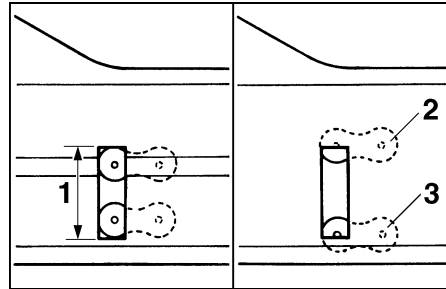

1. USABLE RANGE

2. Too tight

3. Too loose

4. Chain slack is correct if the full end of the chain link can be seen in the usable range as shown in illustration.
5. If any portion of the top or bottom of the chain link end is hidden, adjust the chain.

PERIODIC MAINTENANCE AND MINOR REPAIR

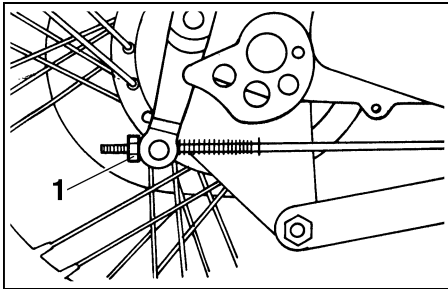

1. Adjusting nut

EAU01533

Drive chain slack adjustment

1. Loosen the rear brake adjusting nut.
2. Loosen the wheel axle nut.

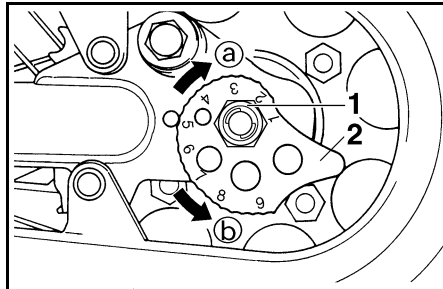

1. Axle nut
2. Chain adjusting plate

3. To tighten the chain, turn the chain adjusting plates in direction Ⓐ. To loosen the chain, turn the chain adjusting plates in direction Ⓑ and push the wheel forward. Turn each chain adjusting plate to exactly the same position to maintain correct axle alignment.

EC000096

CAUTION:

Too little chain slack will overload the engine and other vital parts. Keep the slack within the specified limits.

4. Tighten the wheel axle nut to the specified torque.

Tightening torque:
Wheel axle nut:
65 Nm (6.5 m·kg)

5. Adjust the brake pedal free play.

EW000103

⚠ WARNING

Check the operation of the brake light after adjusting the rear brake.

Drive chain lubrication

EAU01106*

The chain consists of many parts which work with each other. If the chain is not maintained properly, it will wear out quickly. Therefore, the chain must be serviced regularly. This service is especially necessary when riding in dusty areas.

The drive chain should be lubricated every 500 km. First, remove all dirt and mud from the chain with a brush or cloth. Then, spray any of the many brands of spray-type chain lubricant between both rows of side plates and on all center rollers.

To clean the chain thoroughly, remove it from the motorcycle, dip it in solvent, and clean out as much dirt as possible. Then, take the chain out of the solvent to dry it, and immediately lubricate it to prevent it from rusting.

Cable inspection and lubrication

EAU02962

EW000112



Damage to the outer housing of cables may lead to internal rusting and interfere with the cable movement. Replace damaged cables as soon as possible to prevent unsafe conditions.

Lubricate the cables and cable ends. If a cable does not operate smoothly, ask a Yamaha dealer to replace it.

Recommended lubricant:
Engine oil

Throttle cable and grip lubrication

EAU00773

The throttle twist grip assembly should be greased at the time that the cable is lubricated, since the grip must be removed to get at the end of the throttle cable. After removing the screws, hold the end of the cable up in the air and put in several drops of lubricant. With the throttle grip disassembled, coat the metal surface of the grip assembly with a suitable all-purpose grease.

PERIODIC MAINTENANCE AND MINOR REPAIR

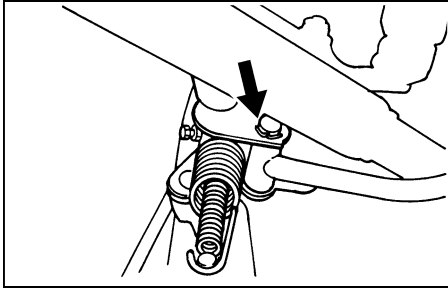

EAU02984

Brake and shift pedal lubrication

Lubricate the pivoting parts.

Recommended lubricant:
Engine oil

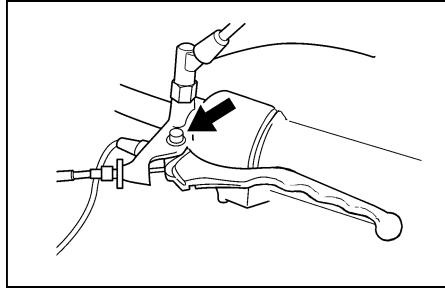

EAU02985

Brake and clutch lever lubrication

Lubricate the pivoting parts.

Recommended lubricant:
Engine oil

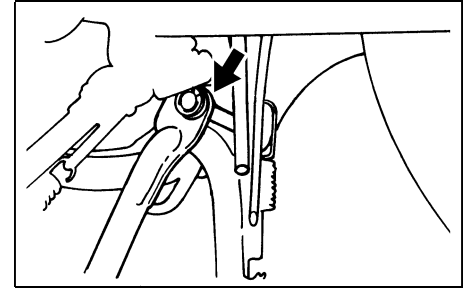

EAU02965

Center and sidestand lubrication

Lubricate the pivoting and mating joints.

Check to see that the center and sidestand move up and down smoothly.

Recommended lubricant:
Engine oil

PERIODIC MAINTENANCE AND MINOR REPAIR

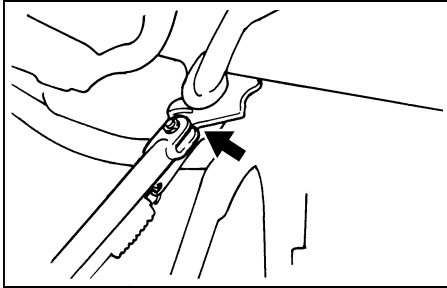

EW000114

! WARNING

If the center and/or sidestand does not move smoothly, consult a Yamaha dealer.

Front fork inspection

Visual check

! WARNING

Securely support the motorcycle so there is no danger of it falling over.

Check for scratches or damage on the inner tube and excessive oil leakage from the front fork.

EAU02939

EW000115

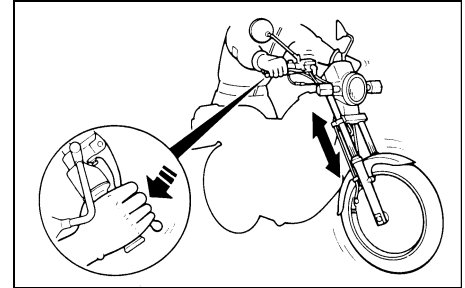

Operation check

1. Place the motorcycle on a level place.
2. Hold the motorcycle in an upright position and apply the front brake.
3. Push down hard on the handlebars several times and check if the fork rebounds smoothly.

EC000098

CAUTION:

If any damage or unsmooth movement is found with the front fork, consult a Yamaha dealer.

PERIODIC MAINTENANCE AND MINOR REPAIR

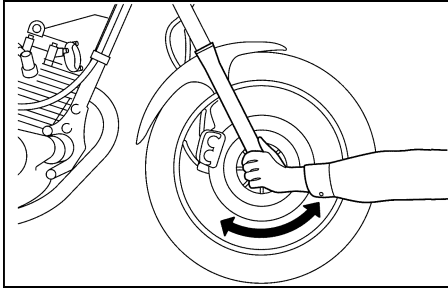

EAU00794

Steering inspection

Periodically inspect the condition of the steering. Worn out or loose steering bearings may be dangerous. Place a stand under the engine to raise the front wheel off the ground. Hold the lower end of the front forks and try to move them forward and backward. If any free play can be felt, ask a Yamaha dealer to inspect and adjust the steering. Inspection is easier if the front wheel is removed.

EW000115

WARNING

Securely support the motorcycle so there is no danger of it falling over.

EAU01144

Wheel bearings

If there is play in the front or rear wheel hub or if the wheel does not turn smoothly, have a Yamaha dealer inspect the wheel bearings.

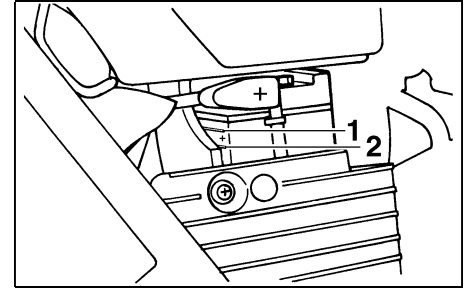

1. Maximum level mark
2. Minimum level mark

EAU01647

Battery

Remove panel A. (See page 6-5 for removal and installation procedures.) Check the level of the battery electrolyte and make sure that the terminals are tight. Fill with distilled water if the electrolyte level is low.

PERIODIC MAINTENANCE AND MINOR REPAIR

EC000099

CAUTION:

When inspecting the battery, be sure the breather hose is routed correctly. If the breather hose is positioned in such a way as to cause battery electrolyte or gas to exit onto the frame, structural and cosmetic damage to the motorcycle can occur.

WARNING

Battery electrolyte is poisonous and dangerous, causing severe burns, etc. It contains sulfuric acid. Avoid contact with skin, eyes or clothing.

ANTIDOTE:

- **EXTERNAL:** Flush with water.
- **INTERNAL:** Drink large quantities of water or milk. Follow with milk of magnesia, beaten egg, or vegetable oil. Call a physician immediately.
- **EYES:** Flush with water for 15 minutes and get prompt medical attention.

Batteries produce explosive gases. Keep sparks, flame, cigarettes etc., away. Ventilate when charging or using in an enclosed space. Always shield your eyes when working near batteries.

KEEP OUT OF REACH OF CHILDREN.

EW000116

Replenishing the battery fluid

A poorly maintained battery will corrode and discharge quickly. The battery fluid should be checked at least once a month. The level should be between the minimum level and maximum level marks. Use only distilled water if refilling is necessary.

EC000100

CAUTION:

Normal tap water contains minerals which are harmful to a battery; therefore, refill only with distilled water.

EW000117

WARNING

Take care not to spill battery fluid on the chain. Battery fluid may weaken the chain causing shorter chain life and possibly result in an accident.

PERIODIC MAINTENANCE AND MINOR REPAIR

EC000103

Battery storage

- When the motorcycle will not be used for a month or longer, remove the battery, fully charge it and store it in a cool, dry place. Completely recharge the battery before reinstallation.
- If the battery will be stored for longer than two months, check the specific gravity of the fluid at least once a month and fully recharge the battery when it is too low.
- Always make sure the connections are correct when putting the battery back in the motorcycle. Make sure the breather hose is properly connected and is not damaged or obstructed.

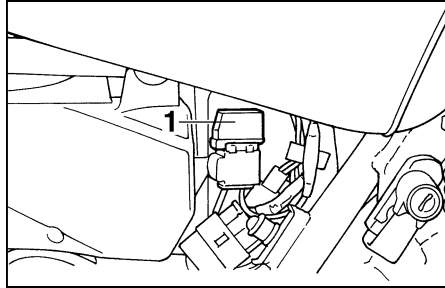

1. Fuse box

EAU01307

Fuse replacement

The fuse is located behind panel B. (See page 6-5 for panel removal and installation procedures.) If the fuse is blown, turn off the main switch and the switch of the circuit in question. Install a new fuse of proper amperage. Turn on the switches and see if the electrical device operates. If the fuse immediately blows again, consult a Yamaha dealer.

CAUTION:

Do not use fuses of higher amperage rating than those recommended. Substitution of a fuse of improper rating can cause extensive electrical system damage and possibly a fire.

Specified fuse:

20 A

PERIODIC MAINTENANCE AND MINOR REPAIR

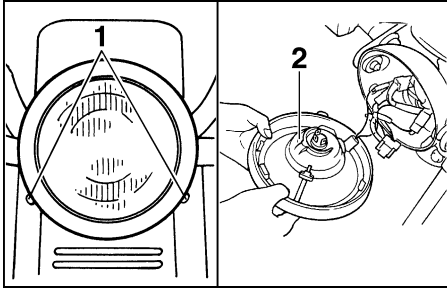

1. Screw (× 2)
2. Bulb holder cover

EAU03003

Headlight bulb replacement

This motorcycle is equipped with a quartz bulb headlight.

If the headlight bulb burns out, replace the bulb as follows:

1. Remove the headlight unit screws.
2. Remove the connector, the headlight unit and then the bulb holder cover.

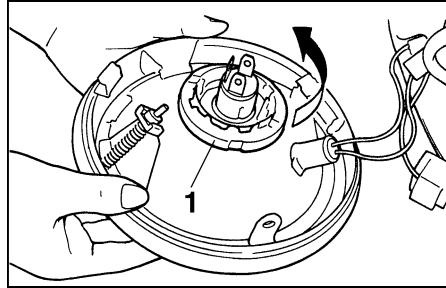

1. Bulb holder
3. Turn the bulb holder counterclockwise to remove it and remove the defective bulb.

EWA00023

! WARNING

Keep flammable products and your hands away from the bulb while it is on, as it is hot. Do not touch the bulb until it cools down.

4. Put a new bulb into position and secure it in place with the bulb holder.

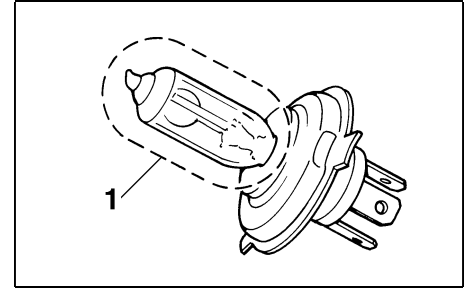

1. Don't touch

ECA00040

CAUTION:

Avoid touching the glass part of the bulb. Keep it free from oil; otherwise, the transparency of the glass, life of the bulb, and luminous flux will be adversely affected. If oil gets on the bulb, thoroughly clean it with a cloth moistened with alcohol or lacquer thinner.

5. Install the bulb holder cover, connector and headlight unit.
Ask a Yamaha dealer to adjust the headlight beam if that adjustment is necessary.

PERIODIC MAINTENANCE AND MINOR REPAIR

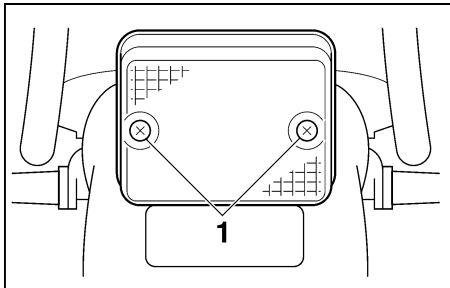

1. Screw (× 2)

Turn signal and tail/brake light bulb replacement

EAU00855*

1. Remove the screws and the lens.
2. Push the bulb inward and turn it counterclockwise.

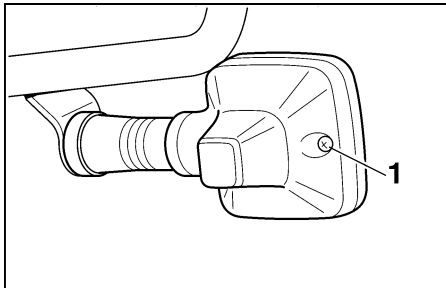

1. Screw

3. Place a new bulb in the socket. Push the bulb inward and turn it clockwise until it engages into the socket.
4. Install the lens and the screws.

EC000108

CAUTION:

Do not over-tighten the screws as the lens may break.

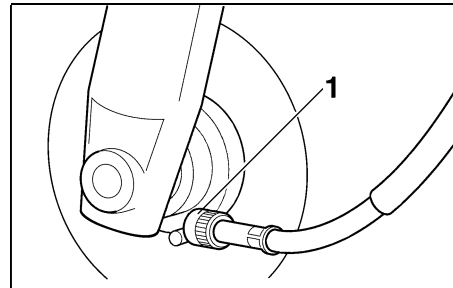

1. Speedometer cable

Front wheel removal

EAU00866

EW000122

! WARNING

- It is advisable to have a Yamaha dealer service the wheel.
- Securely support the motorcycle so there is no danger of it falling over.

1. Place the motorcycle on the centerstand.
2. Remove the speedometer cable from the front wheel side.

PERIODIC MAINTENANCE AND MINOR REPAIR

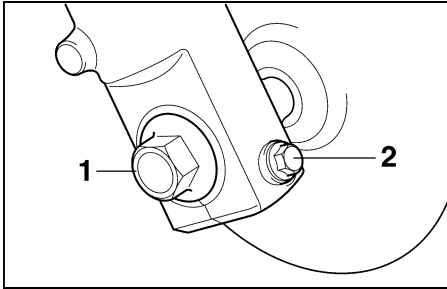

1. Wheel axle
2. Pinch bolt

3. Loosen the pinch bolt.
4. Remove the wheel axle. Make sure the motorcycle is properly supported.

NOTE:

Do not depress the brake lever when the disc and caliper are separated.

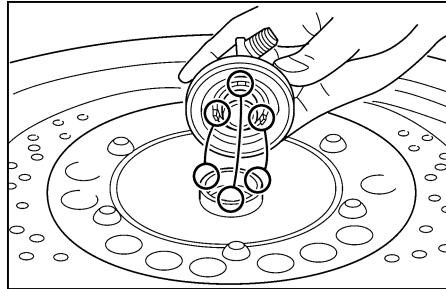

EAU01394

Front wheel installation

1. Install the speedometer gear unit into the wheel hub. Make sure the wheel hub and the speedometer gear unit are installed with the projections meshed into the slots.
2. Lift up the wheel between the front fork legs and guide the brake disc between the brake pads. Make sure the slot in the speedometer gear unit fits over the stopper on the front fork outer tube.
3. Install the wheel axle and let the motorcycle down.

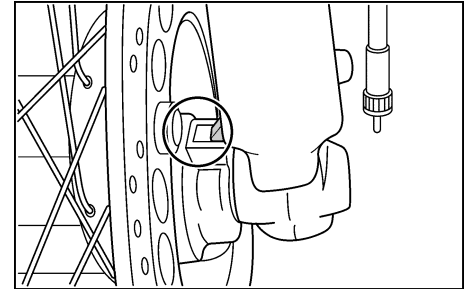

4. Push down hard on the handlebars several times to check for proper fork operation.
5. Tighten the wheel axle to the specified torque.
6. Install the pinch bolt and tighten it to the specified torque.

Tightening torque:

Wheel axle:

59 Nm (5.9 m·kg)

Pinch bolt:

20 Nm (2.0 m·kg)

7. Install the speedometer cable.

PERIODIC MAINTENANCE AND MINOR REPAIR

Rear wheel removal

EAU01116*

EW000122

⚠ WARNING

- It is advisable to have a Yamaha dealer service the wheel.
- Securely support the motorcycle so there is no danger of it falling over.

1. Place the motorcycle on the centerstand.

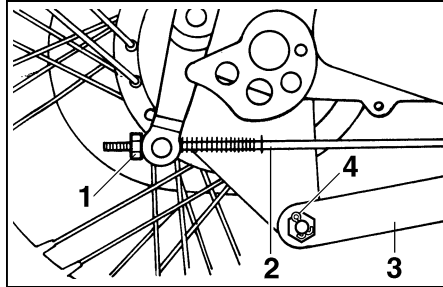

1. Adjusting nut
2. Brake rod
3. Brake torque rod
4. Cotter pin

2. Remove the cotter pin and nut. Then remove the brake torque rod bolt from the brake shoe plate.
3. Remove the brake adjusting nut and brake rod from the brake cam lever.

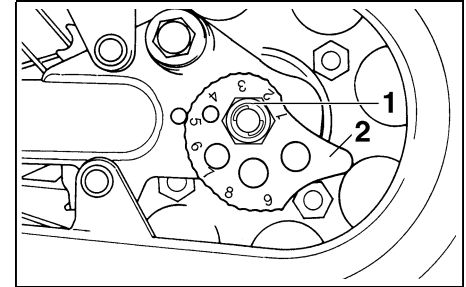

1. Axle nut
2. Chain adjusting plate

4. Loosen the chain adjusting plates on each side.
5. Remove the axle nut.
6. Pull out the rear axle.
7. Push the wheel forward and remove the drive chain.
8. Remove the wheel assembly.

Rear wheel installation

EAU01723*

1. Install the rear wheel and the axle.
2. Install the axle nut and let the motorcycle down.
3. Insert the brake rod into the brake cam lever and install the brake pedal free play adjusting nut.
4. Install the brake torque rod bolt and tighten to the specified tightening torque. Then install a new cotter pin.

Specified torque:

Brake torque rod bolt:
25 Nm (2.5 m·kg)

5. Adjust the drive chain free play. (See page 6-22.)
6. Tighten the axle nut to the specified tightening torque.

Specified torque:

Axle nut:
65 Nm (6.5 m·kg)

7. Adjust the rear brake pedal height and free play. (See page 6-17.)

EW000103



WARNING

Check the operation of the brake light after adjusting the rear brake.

EAU01008

Troubleshooting

Although Yamaha motorcycles receive a rigid inspection before shipment from the factory, trouble may occur during operation.

Any problem in the fuel, compression, or ignition systems can cause poor starting and loss of power. The troubleshooting chart describes a quick, easy procedure for making checks.

If your motorcycle requires any repair, bring it to a Yamaha dealer. The skilled technicians at a Yamaha dealership have the tools, experience, and know-how to properly service your motorcycle. Use only genuine Yamaha parts on your motorcycle. Imitation parts may look like Yamaha parts, but they are often inferior. Consequently, they have a shorter service life and can lead to expensive repair bills.

PERIODIC MAINTENANCE AND MINOR REPAIR

Troubleshooting chart

EAU03009

EW000125



WARNING

Never check the fuel system while smoking or in the vicinity of an open flame.

1. Fuel

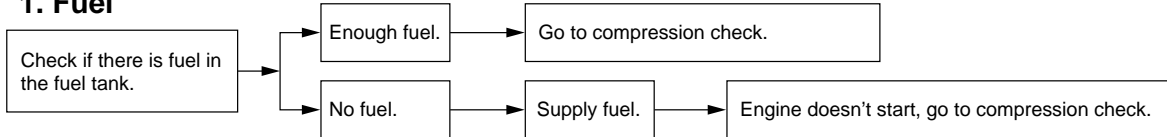

2. Compression

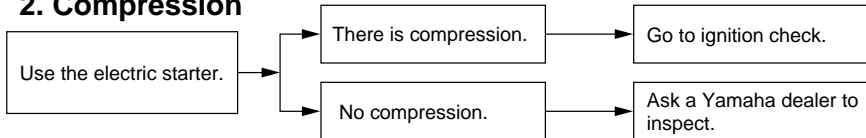

3. Ignition

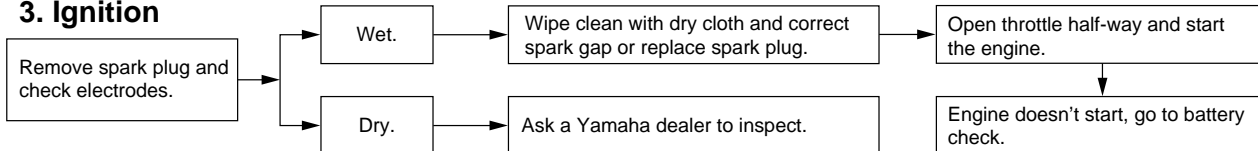

4. Battery

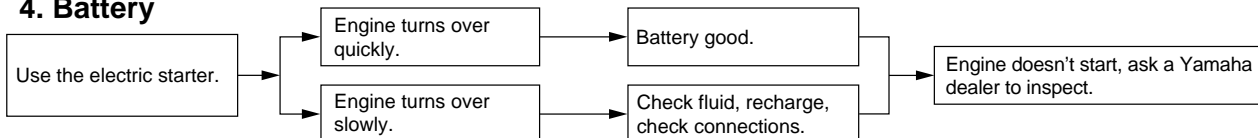

Care

The exposure of its technology makes a motorcycle charming but also vulnerable. Although high-quality components are used, they are not all rust-resistant. While a rusty exhaust pipe may remain unnoticed on a car, it does look unattractive on a motorcycle. Frequent and proper care, however, will keep your motorcycle looking good, extend its life and maintain its performance. Moreover, the warranty states that the vehicle must be properly taken care of. For all these reasons, it is recommended that you observe the following cleaning and storing precautions.

Before cleaning

1. Cover up the muffler outlet with a plastic bag.
2. Make sure that all caps and covers as well as all electrical couplers and connectors, including the spark plug cap, are tightly installed.
3. Remove extremely stubborn dirt, like oil burnt onto the crankcase, with a degreasing agent and a brush, but never apply such products onto seals, gaskets, sprockets, the drive chain and wheel axles. Always rinse the dirt and degreaser off with water.

Cleaning

After normal use

Remove dirt with warm water, a neutral detergent and a soft clean sponge, then rinse with plenty of clean water. Use a tooth or bottle brush for hard-to-reach parts. Tougher dirt and insects will come off more easily if the area is covered with a wet cloth for a few minutes before cleaning.

MOTORCYCLE CARE AND STORAGE

ECA00010

CAUTION:

- Avoid using strong acidic wheel cleaners, especially on spoked wheels. If you do use such products for hard-to-remove dirt, do not leave it on any longer than instructed, then thoroughly rinse it off with water, immediately dry the area and apply a corrosion protection spray.
- Improper cleaning can damage windshields, cowlings, panels and other plastic parts. Use only a soft, clean cloth or sponge with mild detergent and water to clean plastic.
- Do not use any harsh chemical products on plastic parts. Be sure to avoid using cloths or sponges which have been in contact with strong or abrasive cleaning products, solvent or thinner, fuel (gasoline), rust removers or inhibitors, brake fluid, antifreeze or electrolyte.
- Do not use high-pressure washers or steam-jet cleaners since they cause water seepage and deterioration in the following areas: seals (of wheel bearings, swingarm bearings, forks and brakes), electric components (couplers, connectors, instruments, switches and lights), breather hoses and vents.
- For motorcycles equipped with a windshield: Do not use strong cleaners or hard sponges as they will cause dulling or scratching. Some cleaning compounds for plastic may leave scratches on the windshield. Test the product on a small hidden part of the windshield to make sure they do not leave any marks. If the windshield is scratched, use a quality plastic polishing compound after washing.

After riding in the rain, near the sea or on salt-sprayed roads

Since sea salt or salt sprayed on the roads in the winter are extremely corrosive in combination with water, carry out the following steps after each ride in the rain, near the sea or on salt-sprayed roads. (Salt sprayed in the winter may remain on the roads well into spring.)

1. Clean your motorcycle with cold water and soap after the engine has cooled down.

ECA00012

CAUTION:

Do not use warm water since it increases the corrosive action of the salt.

2. Be sure to apply a corrosion protection spray on all (even chrome- and nickel-plated) metal surfaces to prevent corrosion.

After cleaning

1. Dry the motorcycle with a chamois or an absorbing cloth.
2. Immediately dry the drive chain and lubricate it to prevent it from rusting.
3. Use a chrome polish to shine chrome, aluminum and stainless-steel parts, including the exhaust system. (Even the thermally induced discoloring of stainless-steel exhaust systems can be removed through polishing.)
4. To prevent corrosion, it is recommended to apply a corrosion protection spray on all (even chrome- and nickel-plated) metal surfaces.
5. Use spray oil as a universal cleaner to remove any remaining dirt.
6. Touch up minor paint damage caused by stones, etc.
7. Wax all painted surfaces.
8. Let the motorcycle dry completely before storing it or covering it.

WARNING

Make sure that there is no oil or wax on the brakes and tires. If necessary, clean the brake discs and linings with a regular brake disc cleaner or acetone, and wash the tires with warm water and mild soap. Then, carefully test the motorcycle for its braking performance and cornering behavior.

MOTORCYCLE CARE AND STORAGE

ECA00013

CAUTION:

- Apply spray oil and wax sparingly and wipe off any excess.
- Never apply oil or wax on rubber and plastic parts, but treat them with a suitable care product.
- Avoid using abrasive polishing compounds as they wear away the paint.

NOTE:

Consult a Yamaha dealer for advice on what products to use.

Storage

Short-term

Always store your motorcycle in a cool, dry place and, if necessary, protect it against dust with a porous cover.

ECA00014

CAUTION:

- Storing the motorcycle in a poorly ventilated room or covering it with a tarp while it is still wet will allow water and humidity to seep in and cause rust.
- To prevent corrosion, avoid damp cellars, stables (because of the presence of ammonia) and areas where strong chemicals are stored.

Long-term

Before storing your motorcycle for several months:

1. Follow all the instructions in the “Care” section of this chapter.
2. Drain the carburetor float chamber by loosening the drain bolt; this will prevent fuel deposits from building up. Pour the drained fuel into the fuel tank.
3. Only for motorcycles equipped with a fuel cock which has an “OFF” position: Turn the fuel cock to “OFF”.
4. Fill up the fuel tank and add fuel stabilizer (if available) to prevent the fuel tank from rusting and the fuel from deteriorating.
5. Perform the following steps to protect the cylinder, piston rings, etc. from corrosion.

MOTORCYCLE CARE AND STORAGE

- a. Remove the spark plug cap and spark plug.
- b. Pour a teaspoonful of engine oil into the spark plug bore.
- c. Install the spark plug cap onto the spark plug and place the spark plug on the cylinder head so that the electrodes are grounded. (This will limit sparking during the next step.)
- d. Turn the engine over several times with the starter. (This will coat the cylinder wall with oil.)
- e. Remove the spark plug cap from the spark plug, install the spark plug and then the spark plug cap.
6. Lubricate all control cables and the pivoting points of all levers and pedals as well as of the sidestand/centerstand.
7. Check and, if necessary, correct the tire air pressure, then raise the motorcycle so that both of its wheels are off the ground. Alternatively, turn the wheels a little every month in order to prevent the tires from becoming degraded in one spot.
8. Cover up the muffler outlet with a plastic bag to prevent moisture from entering.
9. Remove the battery and fully charge it. Store it in a cool, dry place and recharge it once a month. Do not store the battery in an excessively cold or warm place (less than 0 °C or more than 30 °C). For more information, see “Battery storage” in the chapter “PERIODIC MAINTENANCE AND MINOR REPAIRS”.

NOTE: _____
Make any necessary repairs before storing the motorcycle.

 **WARNING**

When turning the engine over, be sure to ground the spark plug electrodes to prevent damage or injury from sparking.

EWA00003

Specifications

Model	SR125
Dimensions	
Overall length	2,020 mm
Overall width	775 mm
Overall height	1,100 mm
Seat height	745 mm
Wheelbase	1,285 mm
Ground clearance	155 mm
Minimum turning radius	2,100 mm
Basic weight (with oil and full fuel tank)	113 kg
Engine	
Engine type	Air-cooled 4-stroke, SOHC
Cylinder arrangement	Forward-inclined single cylinder
Displacement	124 cm ³
Bore × Stroke	57.0 × 48.8 mm
Compression ratio	10:1
Starting system	Electric starter
Lubrication system	Wet sump

Engine oil

Type

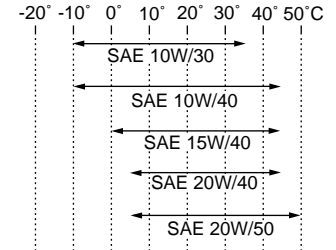

Recommended engine oil classification

API Service SE, SF, SG type or higher

CAUTION:

Be sure to use motor oils that do not contain anti-friction modifiers. Passenger car motor oils (often labeled "Energy Conserving") contain anti-friction additives which will cause clutch and/or starter clutch slippage, resulting in reduced component life and poor engine performance.

Quantity

Periodic oil change	1.0 L
With oil filter replacement	1.1 L
Total amount	1.3 L

Air filter

Wet type element

Fuel

Type	Regular unleaded gasoline
Fuel tank capacity	10.0 L
Fuel reserve amount	1.6 L

Carburetor

Type × quantity	Y24P × 1
Manufacturer	TEIKEI

Spark plug

Manufacturer/Type	NGK / DR8EA
Gap	0.6 ~ 0.7 mm

Clutch type

Wet, multiple-disc

Transmission

Primary reduction system	Spur gear
Primary reduction ratio	3.318
Secondary reduction system	Chain drive
Secondary reduction ratio	3.500
Number of drive chain sprocket teeth (rear/front)	49/14
Transmission type	Constant mesh 5-speed
Operation	Left foot operation

Gear ratio

1st	2.250
2nd	1.476
3rd	1.125
4th	0.926
5th	0.793

Chassis

Frame type	Diamond
Caster angle	26°45'
Trail	90 mm

Tires

Front

Type	With tube
Size	3.00-17 45P
Manufacturer/ model	Inoue / 8F

Rear

Type	With tube
Size	3.50-16 52P
Manufacturer/ model	Inoue / 8RA

SPECIFICATIONS

Maximum load*	160 kg
Air pressure (cold tire)	
Up to 90 kg load*	
Front	175 kPa (1.75 kg/cm ² , 1.75 bar)
Rear	200 kPa (2.00 kg/cm ² , 2.00 bar)
90 kg load ~ maximum load*	
Front	175 kPa (1.75 kg/cm ² , 1.75 bar)
Rear	225 kPa (2.25 kg/cm ² , 2.25 bar)

*Load is total weight of cargo, rider, passenger and accessories

Wheels

Front	
Type	Spoke
Size	17 × 1.60
Rear	
Type	Spoke
Size	16 × 1.85

Brakes

Front	
Type	Single disc brake
Operation	Right hand operation
Fluid	DOT 4 or DOT 3
Rear	
Type	Drum brake
Operation	Right foot operation

Suspension

Front	
Type	Telescopic fork
Rear	
Type	Swingarm

Shock absorbers

Front	Coil spring / oil damper
Rear	Coil spring / oil damper

Wheel travel

Front	120 mm
Rear	76 mm

Electrical system

Ignition system	C.D.I.
Charging system	
Type	C.D.I. magneto
Standard output	14 V, 9 A @ 5,000 r/min
Battery	
Type	12N7-3B-1
Voltage, capacity	12 V, 7 AH

Headlight type

Quartz bulb (halogen)

Bulb voltage, wattage × quantity

Headlight	12 V, 60/55 W × 1
Auxiliary light	12 V, 4 W × 1
Tail/brake light	12 V, 5/21 W × 1
Turn signal light	12 V, 21 W × 4
Meter light	14 V, 3 W × 1
Neutral indicator light	12 V, 1.7 W × 1
High beam indicator light	12 V, 1.7 W × 1
Turn indicator light	12 V, 1.7 W × 1

Fuse 20 A

SPECIFICATIONS

EAU01064

HOW TO USE THE CONVERSION TABLE

All specification data in this manual are listed in SI and METRIC UNITS.

Use this table to convert METRIC unit data to IMPERIAL unit data.

Ex.

METRIC		MULTIPLIER	=	IMPERIAL
**mm	×	0.03937	=	**in
2 mm	×	0.03937	=	0.08 in

CONVERSION TABLE

METRIC TO IMPERIAL			
	Metric unit	Multiplier	Imperial unit
Torque	m-kg	7.233	ft-lb
	m-kg	86.794	in-lb
	cm-kg	0.0723	ft-lb
	cm-kg	0.8679	in-lb
Weight	kg	2.205	lb
	g	0.03527	oz
Speed	km/hr	0.6214	mph
Distance	km	0.6214	mi
	m	3.281	ft
	m	1.094	yd
	cm	0.3937	in
	mm	0.03937	in
Volume / Capacity	cc (cm ³)	0.03527	oz (IMP liq.)
	cc (cm ³)	0.06102	cu-in
	lt (liter)	0.8799	qt (IMP liq.)
	lt (liter)	0.2199	gal (IMP liq.)
Misc.	kg/mm	55.997	lb/in
	kg/cm ²	14.2234	psi (lb/in ²)
	Centigrade (°C)	9/5 + 32	Fahrenheit (°F)

Identification number records

EAU02944

Record the key identification number, vehicle identification number and model label information in the spaces provided for assistance when ordering spare parts from a Yamaha dealer or for reference in case the vehicle is stolen.

1. KEY IDENTIFICATION NUMBER:

2. VEHICLE IDENTIFICATION NUMBER:

3. MODEL LABEL INFORMATION:

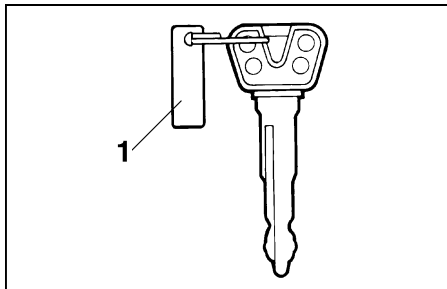

1. Key identification number

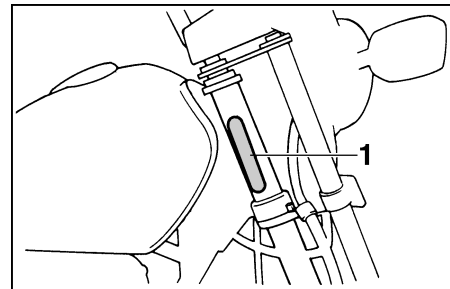

1. Vehicle identification number

Key identification number

EAU01041

The key identification number is stamped on the key tag. Record this number in the space provided and use it for reference when obtaining a new key.

Vehicle identification number

EAU01043

The vehicle identification number is stamped into the steering head pipe. Record this number in the space provided.

NOTE: _____

The vehicle identification number is used to identify your motorcycle and may be used to register your motorcycle with the licensing authority in your state.

CONSUMER INFORMATION

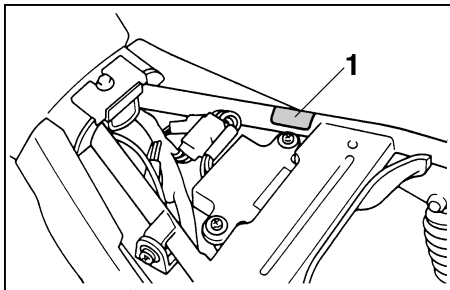

1. Model label

EAU01050

Model label

The model label is affixed to the frame under the seat. (See page 3-8 for seat removal procedures.) Record the information on this label in the space provided. This information will be needed to order spare parts from your Yamaha dealer.



PRINTED ON RECYCLED PAPER

PRINTED IN JAPAN
2001 · 2 - 0.3 × 1 CR
(E)