



⚠ READ THIS MANUAL CAREFULLY!
It contains important safety information.

⚠ LIRE ATTENTIVEMENT CE MANUEL!
Il comprend d'importantes informations de sécurité.

⚠ ¡LEA ESTE MANUAL ATENTAMENTE!
Contiene indicaciones importantes acerca de la seguridad.

OWNER'S MANUAL MANUEL DU PROPRIÉTAIRE MANUAL DEL PROPIETARIO

YFZ05YYXH

BW4-F8199-60

Original instructions
Notice originale
Manual original



PRINTED IN TAIWAN
2016.04



⚠ READ THIS MANUAL CAREFULLY!
It contains important safety information.

OWNER'S MANUAL

YFZ

YFZ05YYXH

⚠ WARNING

This ATV should not be ridden by anyone under 6 years of age.

BW4-F8199-60-E0



Read this manual carefully before operating this vehicle. This manual should stay with this vehicle if it is sold.

EC Declaration of Conformity

conforming to Directive 2006/42/EC

**We, YAMAHA MOTOR CO., LTD. 2500 Shingai, Iwata, Japan,
declare in sole responsibility, that the product**

RF3 AA04W 0G0 000201

YFZ50 (YFZ05YYX) (RF3AA04W0G0000201-)

(Make, model)

**to which this declaration applies, conforms to the essential health and
safety requirements of Directive 2006/42/EC**

(If applicable)

and to the other relevant Directives of EEC

2014/30/EU

(Title and/or number and date of issue of the other Directives of EEC)

(If applicable)

**To effect correct application of the essential health and safety requirements
stated in the Directives of EEC, the following standards and/or technical
specifications were consulted:**

EN15997, ANSI/SVIA 1-2010

(Title and/or number and date of issue of standards and/or specifications)

Manufacturer

AEON MOTOR CO., LTD.

74342 No.41, Nanzhou, Shanshang Dist., Tainan City, Taiwan (R.O.C.)

Authorized Representative

YAMAHA MOTOR EUROPE N.V.

Koolhovenlaan 101, 1119 NC Schiphol-Rijk, The Netherlands

Signature

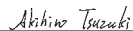
Akihiro Tsuzuki

General Manager

Engineering Division

Recreational Vehicle Business Unit

Vehicle & Solution Business Operations

YAMAHA MOTOR CO., LTD.

Date of Issue

18 March, 2016

INTRODUCTION

Congratulations on your purchase of the Yamaha YFZ05YYXH. This ATV represents the result of many years of Yamaha experience in the production of fine sporting, touring, and pacesetting racing machines. With the purchase of this Yamaha, you can now appreciate the high degree of craftsmanship and reliability that have made Yamaha a leader in these fields.

This manual will provide you with a good basic understanding of the features and operation of this ATV. **This manual includes important safety information. It provides information about special techniques and skills necessary to ride the ATV.** It also includes basic maintenance and inspection procedures. If you have any questions regarding the operation or maintenance of your ATV, please consult a Yamaha dealer.

AN IMPORTANT SAFETY MESSAGE:

- Read this manual completely before operating your ATV. Make sure you understand all instructions.
- Pay close attention to the warning and notice labels on the ATV.
- This ATV should not be operated by a child under 6 years of age.

AN IMPORTANT NOTE TO PARENTS:

This ATV is not a toy. Before you let your child ride this ATV, you should understand the instructions and warnings in this Owner's Manual. Then be sure your child understands and will follow them. Children differ in skills, physical abilities and judgment. Some children may not be able to operate an ATV safely. Parents should supervise their child's use of the ATV at all times. Parents should permit continued use only if they determine that the child has the ability to operate the ATV safely.



Your ATV was delivered with an adjustable speed limiter. Yamaha recommends that all beginners start off to limit the amount of speed available while they learn. The adjusting screw may be gradually turned out as the beginner becomes more familiar with operating the ATV. Parents should decide when to adjust the ATV for more power as their youngster's riding skills improve. Once the ATV rider can operate with skill at the top speed permitted by adjusting the vehicle speed limiter alone, the engine speed limiter plate can be removed. Since removal of this limiter will result in a significant increase in power, turn the vehicle speed limiter adjusting screw completely back in again; adjust it out in stages as done previously.

If your child is a beginner or is inexperienced, he or she should take a training course.

IMPORTANT MANUAL INFORMATION

FAILURE TO FOLLOW THE WARNINGS CONTAINED IN THIS MANUAL CAN RESULT IN SERIOUS INJURY OR DEATH.

Particularly important information is distinguished in this manual by the following notations:

	This is the safety alert symbol. It is used to alert you to potential personal injury hazards. Obey all safety messages that follow this symbol to avoid possible injury or death.
	A WARNING indicates a hazardous situation which, if not avoided, could result in death or serious injury.
	A NOTICE indicates special precautions that must be taken to avoid damage to the vehicle or other property.
TIP	A TIP provides key information to make procedures easier or clearer.

* Product and specifications are subject to change without notice.

EBU17351

IMPORTANT NOTICE

EBU17373

This ATV is designed and manufactured for use on unpaved surfaces only. It is unsafe to operate this ATV on any paved surface, paved street, paved road or motorway.

Please check your local riding laws and regulations before operating this ATV.

EBU33790

**YFZ05YYXH
OWNER'S MANUAL
©2016 by Yamaha Motor Co., Ltd.
1st edition, March 2016
All rights reserved.
Any reprinting or unauthorized use
without the written permission of
Yamaha Motor Co., Ltd.
is expressly prohibited.
Printed in Taiwan.**

TABLE OF CONTENTS

LOCATION OF THE WARNING AND SPECIFICATION LABELS	1-1	Starter (choke)	4-11
SAFETY INFORMATION	2-1	Seat	4-12
DESCRIPTION.....	3-1	Adjusting the rear shock absorber assembly	4-13
Left view	3-1	PRE-OPERATION CHECKS	5-1
Right view.....	3-1	Fuel	5-3
Controls and instruments.....	3-2	Engine oil	5-3
INSTRUMENT AND CONTROL FUNCTIONS.....	4-1	Transmission oil.....	5-3
Main switch	4-1	Front and rear brakes	5-3
Handlebar switches	4-1	Throttle lever.....	5-3
Engine stop switch with lanyard	4-2	Drive chain.....	5-3
Throttle lever	4-3	Tires	5-3
Speed limiter	4-3	Chassis fasteners	5-6
Front brake lever	4-5	Instruments and switches.....	5-6
Rear brake lever	4-6	OPERATION	6-1
Parking brake	4-6	Starting a cold engine.....	6-1
Kickstarter	4-7	Starting a warm engine.....	6-3
Fuel tank cap	4-8	Engine break-in.....	6-3
Fuel	4-8	Parking.....	6-3
Fuel cock.....	4-10	Parking on a slope.....	6-4
		Accessories and loading	6-5

RIDING YOUR ATV	7-1	Cleaning the air filter element	8-16
GETTING TO KNOW YOUR ATV	7-2	Cleaning the spark arrester	8-19
RIDE WITH CARE AND GOOD		Adjusting the carburetor	8-20
JUDGMENT	7-2	Adjusting the engine idling speed	8-20
BE CAREFUL WHERE YOU RIDE.....	7-9	Adjusting the throttle lever free play	8-21
TURNING YOUR ATV.....	7-12	Valve clearance.....	8-22
CLIMBING UPHILL	7-13	Brakes.....	8-22
RIDING DOWNHILL	7-16	Checking the front and rear brake	
CROSSING A SLOPE.....	7-17	shoes	8-22
CROSSING THROUGH SHALLOW		Adjusting the front brake lever free play...	8-23
WATER.....	7-18	Adjusting the rear brake lever free play ...	8-25
RIDING OVER ROUGH TERRAIN	7-20	Drive chain slack.....	8-26
SLIDING AND SKIDDING.....	7-20	Cleaning and lubricating the drive	
WHAT TO DO IF.....	7-21	chain	8-28
WHAT TO DO.....	7-22	Checking and lubricating the cables	8-29
		Checking and lubricating the front and	
PERIODIC MAINTENANCE AND		rear brake levers	8-29
ADJUSTMENT.....	8-1	Checking the wheel hub bearings	8-30
Owner's manual and tool kit	8-2	Lubricating the front arm pivots	8-30
Periodic maintenance chart for the		Lubricating the front knuckle pivots	8-31
emission control system	8-3	Lubricating the steering shaft	8-31
General maintenance and lubrication		Battery	8-32
chart	8-5	Replacing the fuse.....	8-35
Removing and installing the panel.....	8-9	Removing a wheel	8-35
Checking the spark plug	8-9	Installing a wheel	8-36
Engine oil.....	8-11	Troubleshooting.....	8-37
Transmission oil	8-14	Troubleshooting chart	8-38

CLEANING AND STORAGE	9-1
Cleaning	9-1
Storage.....	9-2
SPECIFICATIONS	10-1
CONSUMER INFORMATION	11-1
Identification numbers	11-1
INDEX.....	12-1

LOCATION OF THE WARNING AND SPECIFICATION LABELS

Read and understand all of the labels on your ATV. These labels contain important information for safe and proper operation.

Never remove any labels from your ATV. If a label becomes difficult to read or comes off, request a replacement label from your Yamaha dealer.

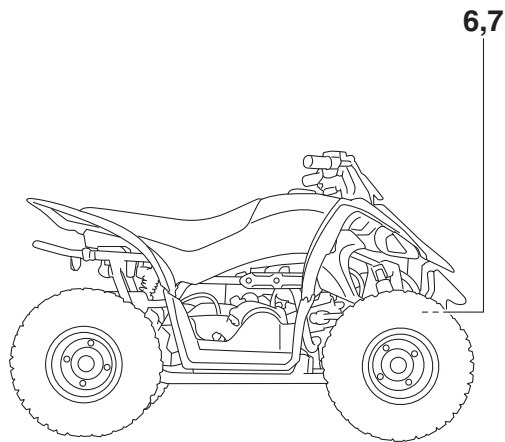
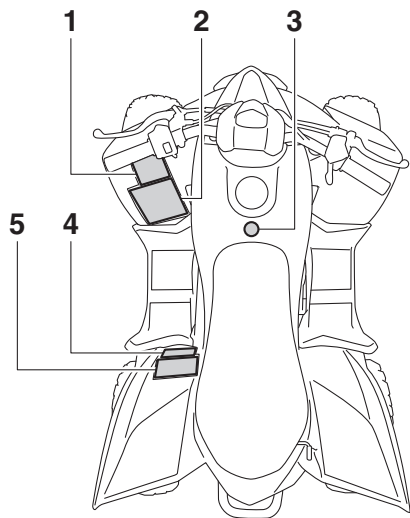

1

1

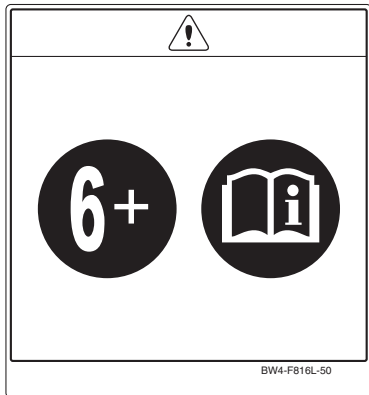

3



2



4

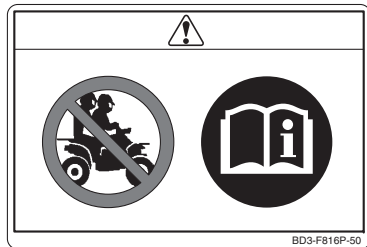

5

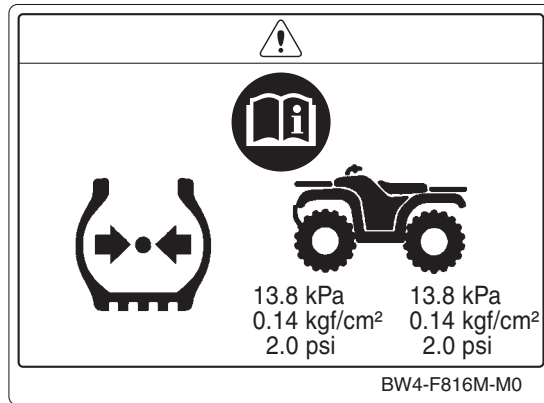

6





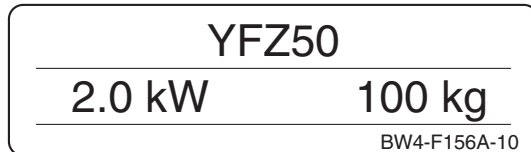





7



1

Familiarize yourself with the following pictograms and read the explanatory text, then make sure to check the pictograms that apply to your model.

	<p>Read the Owner's manual.</p>		<p>For ATV Type 1 category Y12, use from 12 years old. Operation of this ATV by children under the age of 12 increases the risk of severe injury or death. Adult supervision required for children under age 16.</p>
	<p>ALWAYS use an approved helmet and protective gear.</p>		<p>Use from 16 years old. Operating this ATV if you are under the age of 16 increases your chance of severe injury or death.</p>
	<p>Use from 6 years old. Operating this ATV if you are under the age of 6 increases your chance of severe injury or death. Adult supervision required for children under age 16.</p>		<p>NEVER use on paved roads.</p>
	<p>Use from 10 years old. Operating this ATV if you are under the age of 10 increases your chance of severe injury or death. Adult supervision required for children under age 16.</p>		<p>NEVER carry passengers.</p>



NEVER use with drugs or alcohol.



Measure the tire pressure when the tires are cold.



NEVER store fuel or flammable liquids.



Adjust the tire pressure.
Improper tire pressure can cause loss of control.
Loss of control can result in severe injury or death.

** kPa ** kPa
** kgf/cm² ** kgf/cm²
** psi ** psi



This unit contains high-pressure nitrogen gas.
Mishandling can cause an explosion. Do not incinerate, puncture or open.



Turning the ATV in 4WD-LOCK ("DIFF.LOCK") takes more effort.
Operate at a slow speed and allow extra time and distance for maneuvers to avoid loss of control.



Use unleaded gasoline only.



This pictogram shows the loading limits and/or maximum load capacity for this ATV. Follow all load limits and other loading guidelines in this manual.
Load may include the driver, passenger, human protective gear, accessories, goods, luggage, and all other load related items. Make sure you do not exceed the load limits. Overloading can cause loss of control. Loss of control can result in severe injury or death.



This pictogram shows trailer Hitch Tow weight limit. (Combined weight of the trailer and all cargo in the trailer.)
Overloading can cause loss of control. Loss of control can result in severe injury or death.



This pictogram shows trailer Hitch Tongue weight limit. (Weight on the trailer tongue.)
Overloading can cause loss of control. Loss of control can result in severe injury or death.

	<ul style="list-style-type: none"> ① Model Name ② Max. Power ③ Mass In Running Order
	<ul style="list-style-type: none"> ① Year of construction

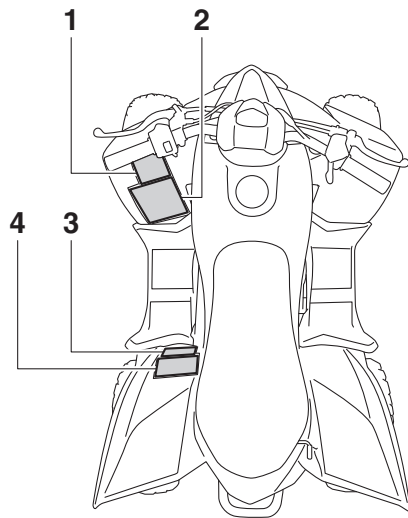

1

1

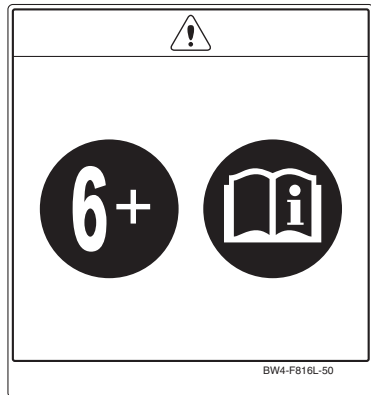

2



3

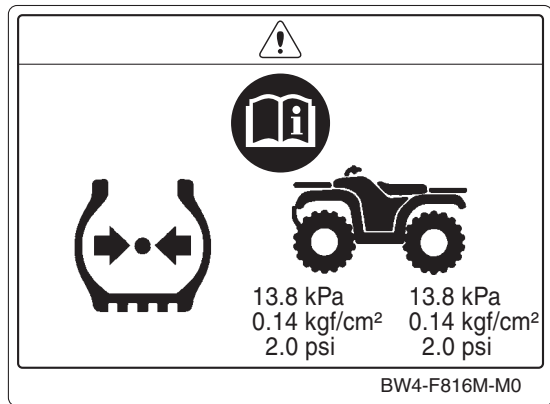

4

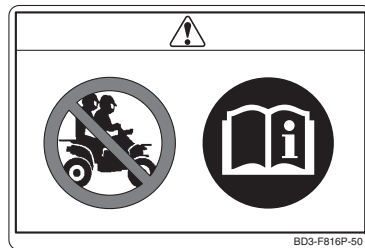

1

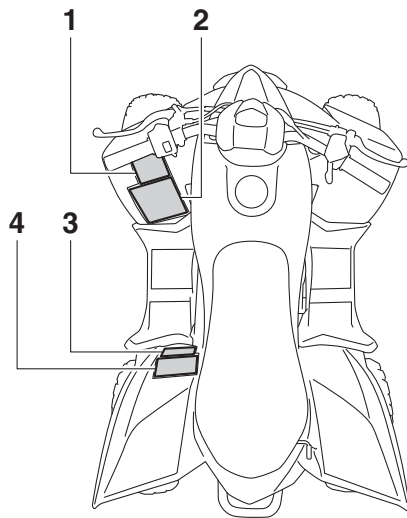

1

⚠ WARNING

**UNDER
6**

Operation of this ATV by children under the age of 6 increases the risk of severe injury or death.

Adult supervision required for children under age 16.

NEVER permit children under age 6 to operate this ATV.

BW4-F816L-00

2

⚠ WARNING

Improper ATV use can result in SEVERE INJURY or DEATH.

 **ALWAYS USE AN APPROVED HELMET AND PROTECTIVE GEAR**

 **NEVER USE ON PUBLIC ROADS**

 **NEVER CARRY PASSENGERS**

 **NEVER USE WITH DRUGS OR ALCOHOL**

NEVER operate :

- without proper training or instruction.
- at speeds too fast for your skills or the conditions.
- on public roads-a collision can occur with another vehicle.
- with a passenger-passengers affect balance and steering and increase risk of losing control.

ALWAYS :

- use proper riding techniques to avoid vehicle overturns on hills and rough terrain and it turns.
- avoid paved surfaces-pavement may seriously affect handling and control.

LOCATE AND READ OWNER'S MANUAL. FOLLOW ALL INSTRUCTIONS AND WARNINGS.

BD3-F1568-60

1

3

⚠ WARNING

Improper tire pressure or overloading can cause loss of control.

Loss of control can result in severe injury or death.

OPERATING TIRE PRESSURE : Set with tires cold

- Recommended : Front : **13.8 kPa (2.0 psi)**

- Rear : **13.8 kPa (2.0 psi)**

- Minimum : Front : **12.4 kPa (1.8 psi)**

- Rear : **12.4 kPa (1.8 psi)**

- Never set tire pressure below minimum.

- It could cause the tire to dislodge from the rim.

LOADING

- Maximum weight capacity : **41 kg (90 lbs.)**

- Includes weight of operator, cargo and accessories.

BW4-F816M-60

4

⚠ WARNING



NEVER ride as a passenger.

Passengers can cause a loss of control, resulting in **SEVERE INJURY** or **DEATH**.

BD3-F151H-00



SAFETY INFORMATION

EBU36351

AN ATV IS NOT A TOY AND CAN BE HAZARDOUS TO OPERATE.

An ATV handles differently from other vehicles, including motorcycles and cars. A collision or roll-over can occur quickly, even during routine maneuvers such as turning and riding on hills or over obstacles, if you fail to take proper precautions.

SEVERE INJURY OR DEATH can result if you do not follow these instructions:

- Read this manual and all labels carefully and follow the operating procedures described.
- Never operate an ATV without proper training or instruction. Take a training course. Beginners should receive training from a certified instructor. Contact an authorized ATV dealer to find out about the training courses nearest you.
- Always follow the age recommendation:
 - A child under 6 years old should never operate an ATV with engine size greater than 50 cc.

- A child under 12 years old should never operate an ATV with engine size greater than 70 cc.
- A child under 16 years old should never operate an ATV with engine size greater than 90 cc.
- Never allow a child under age 16 to operate an ATV without adult supervision, and never allow continued use of an ATV by a child if he or she does not have the abilities to operate it safely.
- Never carry a passenger on an ATV.
- This vehicle is intended for off-road use only. Do not operate on any paved surfaces such as: sidewalks, driveways, parking lots, paved roads, public streets or other motorway.
- Watch carefully for other vehicles when operating on unpaved public streets or roads. Make sure you know your country's laws and regulations before you ride on unpaved public streets or roads.
- Never operate an ATV without wearing an approved motorcycle helmet that fits properly. You should also wear eye protection (goggles or face shield), gloves, boots, a long-sleeved shirt or a jacket, and long pants.

- Never consume alcohol or drugs before or while operating this ATV.
- Never operate at speeds too fast for your skills or the riding conditions. Always go at a speed that is proper for the terrain, visibility, operating conditions, and your experience.
- Never attempt wheelies, jumps, or other stunts.
- Always inspect your ATV each time you use it to make sure it is in safe operating condition. Always follow the inspection and maintenance procedures and schedules described in this manual.
- Always keep both hands on the handlebars and both feet on the footrests of the ATV during operation.
- Always go slowly and be extra careful when operating on unfamiliar terrain. Always be alert to changing terrain conditions when operating the ATV.
- Never operate on excessively rough, slippery or loose terrain until you have learned and practiced the skills necessary to control the ATV on such terrain. Always be especially cautious on these kinds of terrain.
- Always follow proper procedures for turning as described in this manual. Practice turning at low speeds before attempting to turn at faster speeds and never turn at excessive speeds.
- Never operate the ATV on hills too steep for the ATV or for your abilities. Practice on smaller hills before attempting larger hills.
- Always follow proper procedures for climbing hills as described in this manual. Check the terrain carefully before you start up any hill. Never climb hills with excessively slippery or loose surfaces. Shift your weight forward. Never open the throttle suddenly or make sudden gear changes. Never go over the top of a hill at high speed.
- Always follow proper procedures for going down hills and for braking on hills as described in this manual. Check the terrain carefully before you start down any hill. Shift your weight backward. Never go down a hill at high speed. Avoid going down a hill at an angle that would cause the vehicle to lean sharply to one side. Go straight down the hill where possible.
- Always follow proper procedures for crossing the side of a hill as described in this manual. Avoid hills with excessively slippery or loose

surfaces. Shift your weight to the uphill side of the ATV. Never attempt to turn the ATV around on any hill until you have mastered the turning technique described in this manual on level ground. Avoid crossing the side of a steep hill if possible.

- Always use proper procedures if you stall or roll backwards when climbing a hill. If you stall or roll backwards, follow the special procedure for braking described in this manual. Dismount on the uphill side or to a side if pointed straight uphill. Turn the ATV around and remount, following the procedure described in this manual.
- Always check for obstacles before operating in a new area.
- Never attempt to operate over large obstacles, such as large rocks or fallen trees. Always follow proper procedures when operating over obstacles as described in this manual.
- Always be careful when skidding or sliding. Learn to safely control skidding or sliding by practicing at low speeds and on level, smooth terrain. On extremely slippery surfaces, such as ice, go slowly and be very cautious in order to reduce the chance of skidding or sliding out of control.
- Never operate an ATV in fast flowing water or in water deeper than that recommended in this manual. Remember that wet brakes may have reduced stopping ability. Test your brakes after leaving water. If necessary, apply them several times to let friction dry out the linings.
- Always use the size and type of tires specified in this manual.
- Always maintain proper tire pressure as described in this manual.
- Never exceed the stated load capacity for an ATV. Cargo should be properly distributed and securely attached. Reduce speed and follow instructions in this manual for carrying cargo or pulling a trailer. Allow greater distance for braking.
- Do not operate your ATV during darkness unless it is equipped with a properly functioning headlight. Off-road riding is inherently dangerous and additionally, off-road trails do not have streetlights to guide you.
- Never maintain an ATV without proper knowledge. Contact an authorized ATV dealer to inform you on basic ATV maintenance. Certain maintenance can only be carried out by certified staff.

In the event of an accident

1. If serious injuries are incurred, you may be safer staying next to your vehicle; it may shield you from oncoming riders. Depending on your injuries and position in the trail; you must make a judgment call as to whether you should move to a position off the trail. If you have sustained head, neck, or back injuries, or cannot feel your limbs, you should not move. Keep your helmet on and remain motionless. Lie down next to your vehicle and wait for help.
2. If less serious injuries are incurred and you can walk, then move to a position off the trail. Check yourself for injuries and apply first aid as needed.
3. If your injuries are light, when safe to do so, move your vehicle off the trail to avoid collisions with oncoming riders. Check for injuries and apply first aid as necessary. If you can physically operate your vehicle, inspect your vehicle. If the vehicle is in safe operating condition and you can safely operate it, restart it and ride gently back to camp or other known location where you can receive medical at-

tention. If necessary, contact your riding party or local authorities to let them know where you are and what has happened.

In the event of a breakdown

1. If your vehicle will not restart or is not in safe operating condition, turn off the main switch and engine stop switch. If the breakdown occurs at twilight or night, leave the main switch on so that your lights may warn other riders of your stopped vehicle.
2. Get out of danger. Check for oncoming vehicles and when safe, push your vehicle to the side of the trail or even off the main trail to avoid any possible collisions with oncoming riders. If you cannot move your vehicle by yourself, when safe, walk to the nearest vantage point and signal an oncoming rider to help you push your vehicle to a safe place off the trail.
3. Inspect your vehicle for any immediate hazardous conditions. The most obvious hazardous conditions are leaking fuel and ungrounded or broken wiring. Visually check for broken wiring and leaking fuel. Leaking fuel can be confirmed by the odor of gasoline.

4. Once immediate safety hazards are confirmed not to exist, you may remove your helmet to more closely inspect your vehicle. Check for external signs of wear, broken parts, fluid leaks, cracks in the frame, suspension damage, wheel damage, and so on. Fuel, oil, and coolant usually give off a noticeable odor.
5. If your vehicle will not restart or if it is unsafe to ride, then turn off all vehicle systems (engine stop switch, main switch, and fuel cock), and then signal or go for help.

Aftermarket Parts, Accessories, and Modifications

While you may find aftermarket products similar in design and quality to genuine Yamaha accessories, recognize that some aftermarket accessories or modifications are not suitable because of potential safety hazards to you or others. Installing aftermarket products or having other modifications performed to your vehicle that change any of the vehicle's design or operation characteristics can put you and others at greater risk of serious injury or death. You are responsible for injuries re-

lated to changes in the vehicle. Keep the following guidelines in mind, as well as those provided under "Loading" when mounting accessories.

- Never install accessories that would impair the performance of your ATV. Carefully inspect the accessory before using it to make sure that it does not in any way reduce ground clearance, limit suspension travel, steering travel or control operation.
- Accessories fitted to the ATV can create instability due to improper weight distribution.
- Bulky or large accessories may seriously affect the stability of the ATV.
- Certain accessories can displace the operator from his or her normal riding position. This improper position limits the freedom of movement of the operator and may limit control ability, therefore, such accessories are not recommended.
- Use caution when adding electrical accessories. If electrical accessories exceed the capacity of the ATV's electrical system, an electric failure could result, which could cause a dangerous loss of lights or engine power.

TEACHING YOUR CHILD TO OPERATE THE ATV

EWB00081

WARNING

2

Never let your child ride an ATV without close adult supervision (a child under 6 should not ride this ATV even with adult supervision).

Promptly correct your child if he or she begins to ride beyond his or her abilities and, if necessary, intervene by pulling the cord (lanyard) to stop the engine.

If the child rides beyond his or her abilities, or rides in terrain that is too difficult, he or she may lose control of the ATV, causing an accident.

Introduce new riding areas slowly and make sure the riding area matches your child's skill level.

You must make the commitment to your child's proper use of the ATV. Your child must rely upon you to be sure he or she has the development, proper training, and proper equipment, as well as an appropriately sized ATV and an appropriate riding area.

Be sure your child is ready to learn how to ride

As a parent, your first step is to decide when your child has the strength, skills, and judgment to learn how to operate an ATV safely. Re-evaluate your child's readiness before every use; a child who is too tired or distracted should not be allowed to operate the ATV.

Be sure your child is properly trained

Your child should take a certified training course. Training will continue with you as the instructor, so you should be sure you thoroughly understand proper riding techniques before continuing to instruct your child. Go through this Owner's Manual page by page with your child and be sure he or she understands how to operate the ATV properly.

Be sure your child is wearing all the proper safety equipment

Your child must always wear an approved motorcycle helmet that fits properly. Your child should also wear the safety equipment described in the Riding Your ATV section of this manual.

Choose an appropriate riding area

Select an area appropriate for your child to learn to ride. (See page 7-9.) Follow the instructions in the Riding Your ATV section of this manual. Choose a large, flat, unpaved road or area that is free of obstacles and away from other vehicles.

Supervise every use of the ATV

Because an adult must supervise every ATV operator under age 16, you should closely watch your child every time he or she uses the ATV. Be ready to intervene immediately if the child is not operating according to your guidelines. This ATV is fitted with an engine stop switch cord (lanyard) device that will let you stop the engine remotely as you walk behind the vehicle.

ENGINE STOP SWITCH CORD

This model has an engine stop switch cord (lanyard) designed for use by an adult supervising the child operating the ATV. When using the engine stop switch cord, be sure the speed limiter on the handlebar is adjusted and the engine speed limiter plate is installed to limit the ATV to a walking speed. (See page 4-3.)

1. Install the cap on the end of the engine stop switch cord onto the engine shut-off switch (white button).
2. Put your fingers in the loop at the other end of the cord.
3. As your child is riding, walk behind the ATV, closely watching his or her actions as well as the path ahead.
4. If there is a potential hazard ahead or if your child is not riding correctly, pull firmly on the cord (lanyard) to stop the engine. Because the ATV will continue to roll for some distance, allow extra time and distance to pull the cord before a potentially hazardous situation might be encountered.

When your child has developed sufficient skill to no longer need you to follow with the cord, securely tie up the cord. However, you must still closely supervise your child at all times during ATV operation.

TIP

The ATV will not start without the cap in place. Be sure to remove the cord and store it in a safe place to prevent operation of the ATV when you are not around to supervise.

! WARNING**Avoid Carbon Monoxide Poisoning**

All engine exhaust contains carbon monoxide, a deadly gas. Breathing carbon monoxide can cause headaches, dizziness, drowsiness, nausea, confusion, and eventually death.

Carbon Monoxide is a colorless, odorless, tasteless gas which may be present even if you do not see or smell any engine exhaust. Deadly levels of carbon monoxide can collect rapidly and you can quickly be overcome and unable to save yourself. Also, deadly levels of carbon monoxide can linger for hours or days in enclosed or poorly ventilated areas. If you experience any symptoms of carbon monoxide poisoning, leave the area immediately, get fresh air, and **SEEK MEDICAL TREATMENT**.

- Do not run engine indoors. Even if you try to ventilate engine exhaust with fans or open windows and doors, carbon monoxide can rapidly reach dangerous levels.
- Do not run engine in poorly ventilated or partially enclosed areas such as barns, garages, or carports.

2

- Do not run engine outdoors where engine exhaust can be drawn into a building through openings such as windows and doors.

! WARNING

When transporting the ATV in another vehicle, be sure it is kept upright and that the fuel cock is in the "OFF" position. Otherwise, fuel may leak out of the carburetor or fuel tank.



DESCRIPTION

EBU17691

Left view

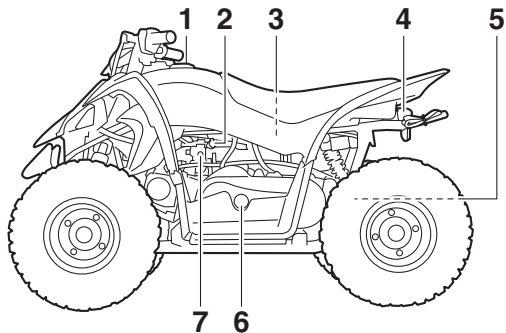

1. Fuel tank cap
2. Fuel cock
3. Air filter
4. Engine stop switch with cord (lanyard)
5. Rear shock absorber assembly spring preload adjusting ring
6. Kickstarter lever cap
7. Throttle stop screw

EBU17701

Right view

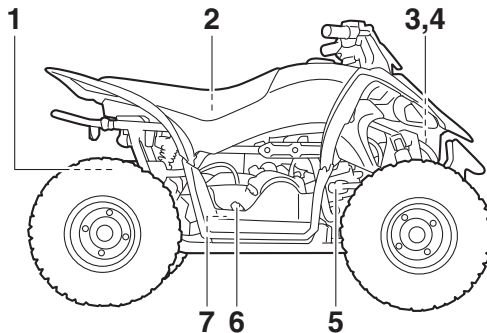

1. Spark arrester
2. Owner's tool kit
3. Fuse
4. Battery
5. Spark plug
6. Engine oil filler cap
7. Transmission oil filler cap

Controls and instruments

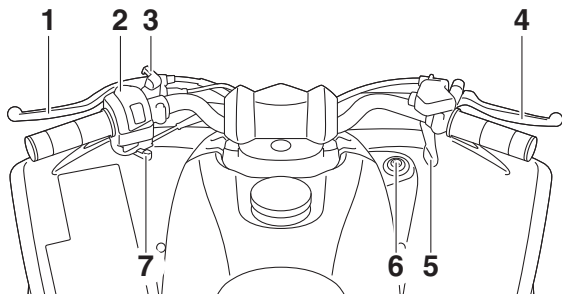
3

1. Rear brake lever
2. Handlebar switches
3. Parking brake lock plate
4. Front brake lever
5. Throttle lever
6. Main switch
7. Starter (choke)

TIP _____
The ATV you have purchased may differ slightly
from the figures shown in this manual.

INSTRUMENT AND CONTROL FUNCTIONS

EBU33850

Main switch

The positions of the main switch are as follows:

ON

All electrical systems are supplied with power, and the engine can be started. The key cannot be removed.

OFF

All electrical systems are off. The key can be removed.

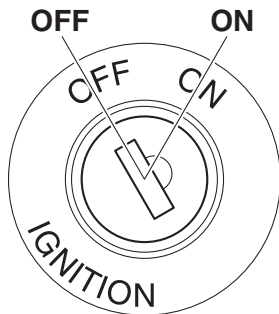

EBU18066

Handlebar switches

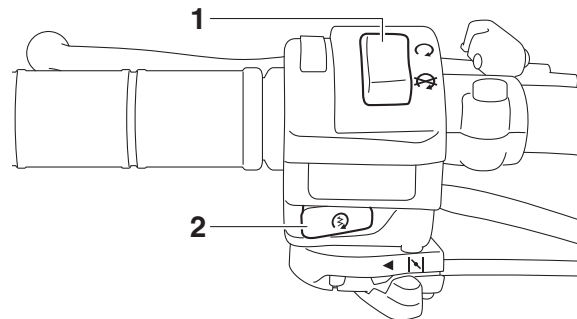

4

1. Engine stop switch “/○”
2. Start switch “”

EBU18081

Engine stop switch “/○”

Set this switch to “○” before starting the engine. The engine stop switch controls the ignition and stops the engine when it is running. Use this switch to stop the engine in an emergency situation. The engine will not start or run when this switch is set to “”.

Start switch “☹”

Push this switch to crank the engine with the starter. See the starting instructions on page 6-1 prior to starting the engine.

Engine stop switch with lanyard**4**

The cap must be attached to the engine stop switch for the engine to run.

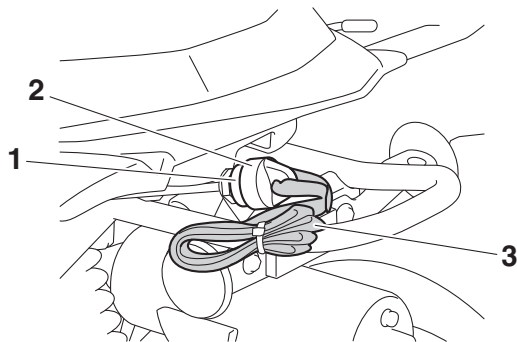

1. Engine stop switch
2. Cap
3. Lanyard

The lanyard should be held by putting your fingers in the loop as shown.

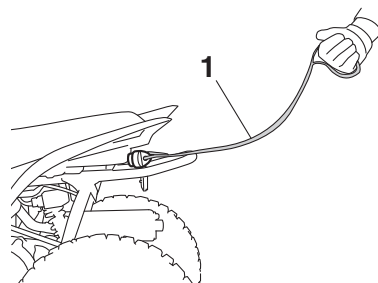

1. Lanyard

Should the ATV be separated from the parent by a distance longer than the lanyard length, the lanyard will pull out the cap and stop the engine. For further explanation of this switch and the lanyard, see “TEACHING YOUR CHILD TO OPERATE THE ATV” in the “SAFETY INFORMATION” section.

TIP

- The engine cannot be started with the cap removed.

- When your child has developed sufficient skill to no longer need you to follow with the lanyard, securely tie up the lanyard. However, you must still closely supervise your child at all times during ATV operation.

EBU18283

Throttle lever

Once the engine is running, pushing the throttle lever will increase the engine speed.

Regulate the speed of the ATV by varying the throttle position. Because the throttle is spring-loaded, the ATV will decelerate, and the engine will return to an idle any time the throttle lever is released.

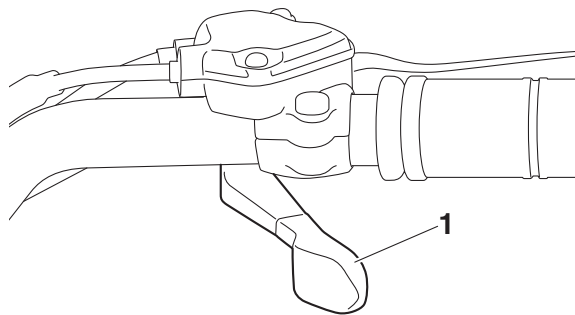

4

1. Throttle lever

Before starting the engine, check the throttle to be sure it is operating smoothly. Make sure it returns to the idle position as soon as the lever is released.

EBU36330

Speed limiter

Your ATV was delivered with two speed limiter devices. A vehicle speed limiter adjusting screw and a removable engine speed limiter plate. Yamaha recommends that all beginning riders start off with the vehicle speed limiter adjusting screw fully turned in and the engine speed limiter plate installed to limit the amount of speed available while they learn.

The vehicle speed limiter keeps the throttle from fully opening, even when the throttle lever is pushed to the maximum. The adjusting screw may be gradually turned out as the beginner becomes more familiar with operating the ATV. Parents should decide when to adjust the ATV for more power as their youngster's riding skills improve.

4

Once the ATV rider can operate with skill at the top speed permitted by adjusting the vehicle speed limiter alone, the engine speed limiter plate can be removed. Since removal of this plate will result in a significant increase in power, turn the vehicle speed limiter adjusting screw completely back in again and adjust it out in stages as done previously.

Vehicle speed limiter

1. Loosen the locknut.
2. To increase the maximum engine power available and the maximum speed of the ATV, turn the adjusting screw in direction (a). To decrease the maximum engine power available and the maximum speed of the ATV, turn the adjusting screw in direction (b). Do not turn the adjusting screw out more than 11 mm (0.43 in) or the throttle cable could be damaged. Always make sure the throttle lever

free play is adjusted to 2.0–3.2 mm (0.08–0.13 in). (See page 8-21.) **WARNING! Improper adjustment of the speed limiter and throttle could cause throttle cable damage or improper throttle operation. You could lose control, resulting in an accident.**

[EWB00242]

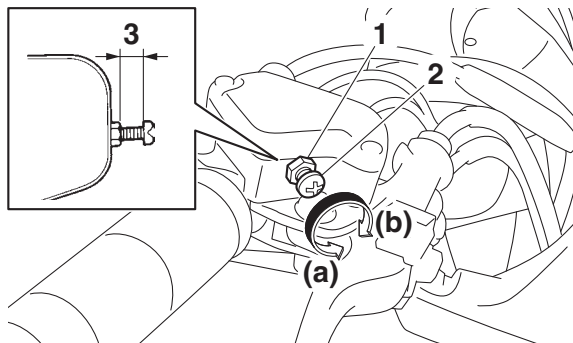

1. Locknut
 2. Adjusting screw
 3. No more than 11 mm (0.43 in)
3. Tighten the locknut.

Engine speed limiter plate

When the engine speed limiter plate is installed, engine speed is limited to 5200 r/min. When this plate is removed, top engine speed (7400 r/min) is available.

Remove the plate as follows.

1. Remove panel A. (See page 8-9.)
2. Loosen the screws, and then remove the plate as shown.

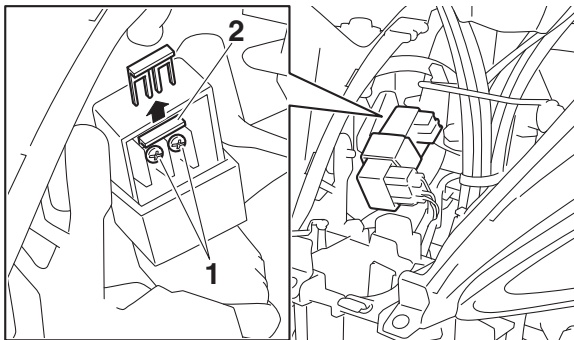

1. Screw
2. Engine speed limiter plate
3. Tighten the screws.
4. Install the panel.

TIP

Store the engine speed limiter plate with the owner's manual so that it is readily available whenever you want to reduce top engine speed.

EBU18392

Front brake lever

The front brake lever is located on the right handlebar. To apply the front brake, pull the brake lever toward the handlebar grip.

4

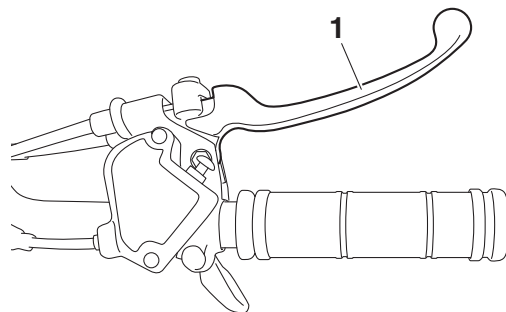

1. Front brake lever

Rear brake lever

The rear brake lever is located on the left handlebar. To apply the rear brake, pull the brake lever toward the handlebar grip.

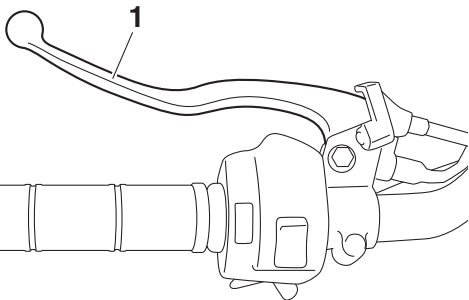

1. Rear brake lever

Parking brake

Use the parking brake before starting the engine or after parking the ATV, especially on a slope. Apply the rear brake lever and push down the lock plate to apply the parking brake. Squeeze the rear brake lever to release the parking brake.

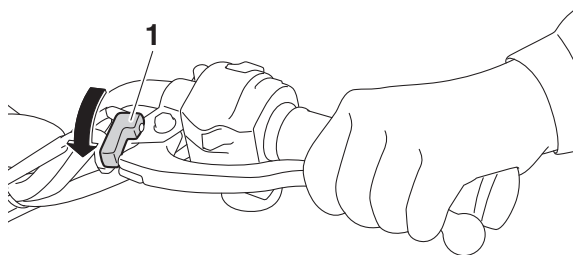

1. Parking brake lock plate

WARNING

- **Always set the parking brake before starting the engine. The ATV could start moving unexpectedly if the parking brake is not applied. This could cause loss of control or a collision.**
- **Always be sure you have released the parking brake before you begin to ride. The brake could overheat if you ride the ATV without releasing the parking brake. You could lose**

braking performance which could cause an accident. You could also wear out the brakes prematurely.

EBU33892

Kickstarter

Use the kickstarter to start the engine when the battery voltage is low. The kickstarter lever is located under the seat. (See page 4-12.)

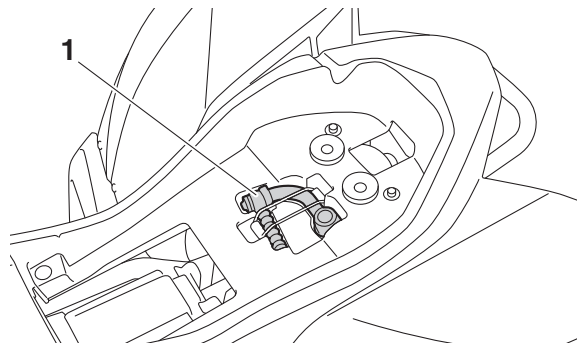

1. Kickstarter lever

1. Remove the kickstarter lever cap.

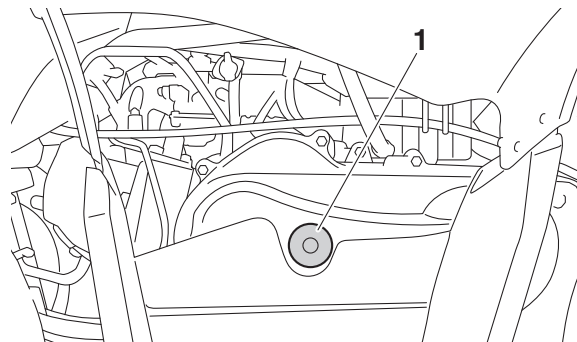

1. Kickstarter lever cap

2. Install the kickstarter lever.
3. Move the kickstarter lever down lightly with your foot until the gears engage, and then push it down smoothly but forcefully.

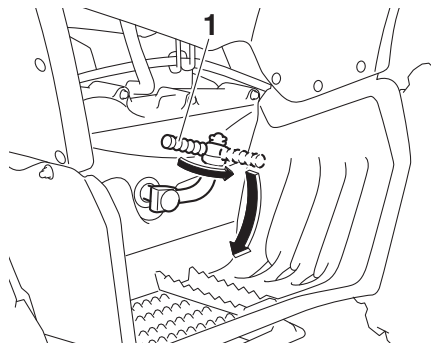

1. Kickstarter lever

4. When the engine has started, remove the kickstarter lever and store it under the seat.
5. Install the kickstarter lever cap.

ECB02300

NOTICE

Do not use the kickstarter if the battery is not installed or if the battery leads are not connected.

EBU18721

Fuel tank cap

Remove the fuel tank cap by turning it counter-clockwise.

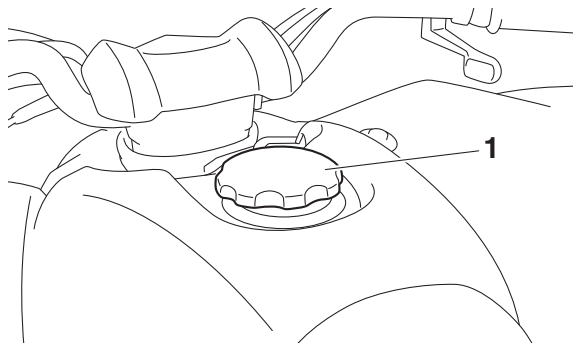

1. Fuel tank cap

EBU18757

Fuel

Make sure there is sufficient gasoline in the tank.

EWB02522

! WARNING

Gasoline and gasoline vapors are extremely flammable. To avoid fires and explosions and to reduce the risk of injury when refueling, follow these instructions.

1. Before refueling, turn off the engine and be sure that no one is sitting on the vehicle. Never refuel while smoking, or while in the vicinity

of sparks, open flames, or other sources of ignition such as the pilot lights of water heaters and clothes dryers.

2. Do not overfill the fuel tank. When refueling, be sure to insert the pump nozzle into the fuel tank filler hole. Stop filling when the fuel reaches the bottom of the filler tube. Because fuel expands when it heats up, heat from the engine or the sun can cause fuel to spill out of the fuel tank.

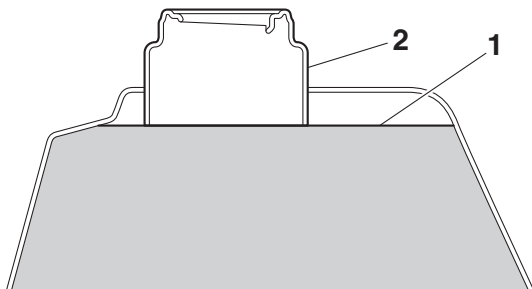

1. Maximum fuel level
2. Fuel tank filler tube

Recommended fuel:

Regular unleaded gasoline only

For Europe: Regular unleaded gasoline only with a research octane number of 95 or higher

Fuel tank capacity:

5.6 L (1.48 US gal, 1.23 Imp.gal)

Fuel reserve amount:

0.7 L (0.18 US gal, 0.15 Imp.gal)

3. Wipe up any spilled fuel immediately.
NOTICE: Immediately wipe off spilled fuel with a clean, dry, soft cloth, since fuel may deteriorate painted surfaces or plastic parts. [ECB00982]
4. Turn the fuel tank cap fully clockwise to make sure it is securely closed.

EWB02532



Gasoline is poisonous and can cause injury or death. Handle gasoline with care. Never siphon gasoline by mouth. If you should swallow some gasoline or inhale a lot of gasoline vapor, or get some gasoline in your eyes, see your doctor

immediately. If gasoline spills on your skin, wash with soap and water. If gasoline spills on your clothing, change your clothes.

ECB00071

NOTICE

Use only unleaded gasoline. The use of leaded gasoline will cause severe damage to internal engine parts, such as the valves and piston rings, as well as to the exhaust system.

4

Your Yamaha engine has been designed to use regular unleaded gasoline with a research octane number of 91 or higher (95 or higher for Europe). If knocking (or pinging) occurs, use a gasoline of a different brand. Use of unleaded fuel will extend spark plug life and reduce maintenance costs.

EBU18821

Fuel cock

The fuel cock supplies fuel from the tank to the carburetor while also filtering it.

The fuel cock lever positions are explained as follows and shown in the illustrations.

OFF

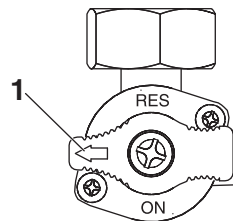

1. Arrow mark positioned over "OFF"

With the fuel cock lever in this position, fuel will not flow. Always turn the fuel cock lever to this position when the engine is not running.

ON

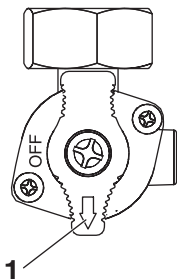

1. Arrow mark positioned over "ON"

With the fuel cock lever in this position, fuel flows to the carburetor. Turn the fuel cock lever to this position when starting the engine and riding.

RES

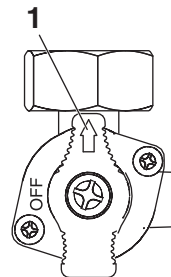

1. Arrow mark positioned over "RES"

This indicates reserve. With the fuel cock lever in this position, the fuel reserve is made available. Turn the fuel cock lever to this position if you run out of fuel while riding. When this occurs, refuel as soon as possible and be sure to turn the fuel cock lever back to "ON"!

EBU18851

Starter (choke) “|↘|”

Starting a cold engine requires a richer air-fuel mixture, which is supplied by the starter (choke). Move the starter (choke) in direction (a) to turn on the starter (choke).

Move the starter (choke) in direction (b) to turn off the starter (choke).
See the “Starting a cold engine” section on page 6-1 for proper operation.

4

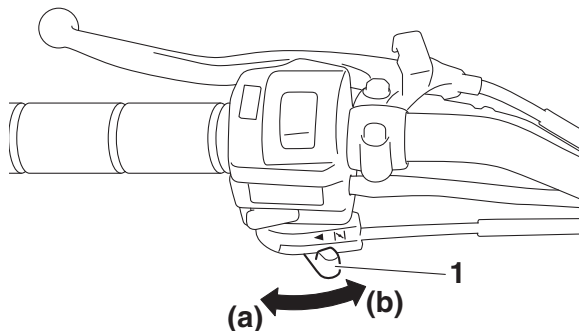

1. Starter (choke) “|< \>|”

EBU36430

Seat

To remove the seat

While pushing the rear of the seat down, pull the seat lock lever upward and then pull up the seat at the rear.

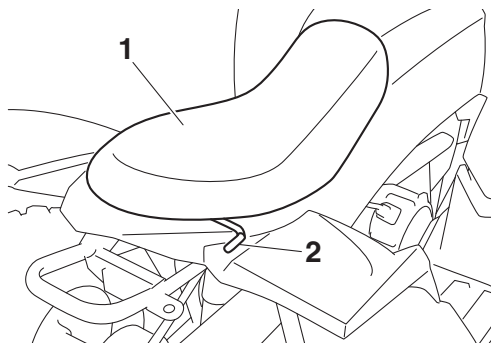

1. Seat
2. Seat lock lever

To install the seat

Insert the projections on the front of the seat into the seat holders and push down on the seat at the rear. Make sure that the seat is securely fitted.

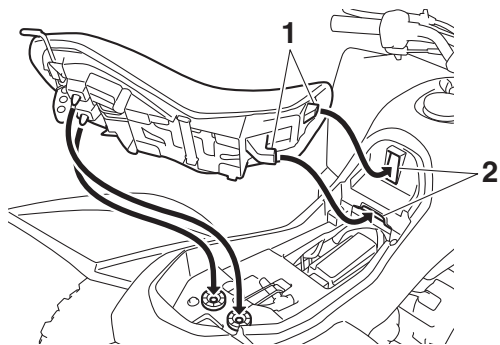

- 1. Projection
- 2. Seat holder

EBU19024

Adjusting the rear shock absorber assembly

The spring preload can be adjusted to suit the rider's weight and the riding conditions.

ECB01091

NOTICE

Never turn the adjusting mechanism beyond the minimum and maximum settings.

Adjust the spring preload as follows.

Turn the spring preload adjusting ring in direction (a) to increase the spring preload and thereby harden the suspension, and in direction (b) to decrease the spring preload and thereby soften the suspension.

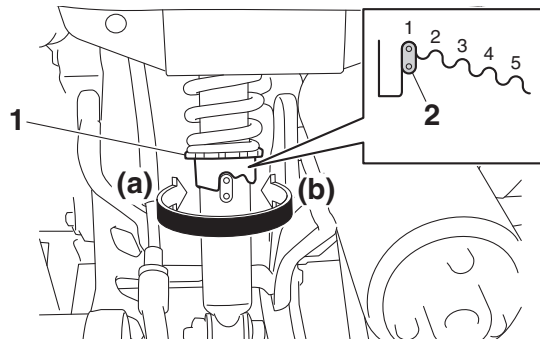

- 1. Spring preload adjusting ring
- 2. Position indicator

TIP

A special wrench can be obtained at a Yamaha dealer to make this adjustment.

4

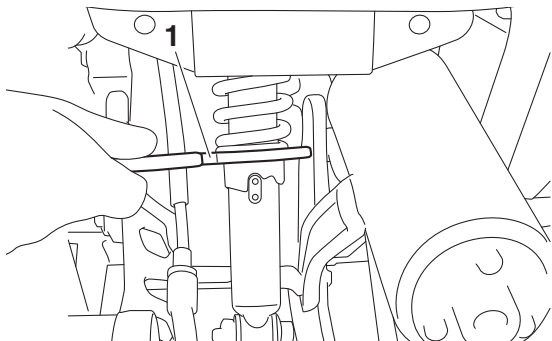

1. Special wrench

Spring preload setting:

Minimum (soft):

1

Standard:

1

Maximum (hard):

5

PRE-OPERATION CHECKS

Inspect your vehicle each time you use it to make sure the vehicle is in safe operating condition. Always follow the inspection and maintenance procedures and schedules described in the Owner's Manual.

EWB00482



WARNING

Failure to inspect or maintain the vehicle properly increases the possibility of an accident or equipment damage. Do not operate the vehicle if you find any problem. If a problem cannot be corrected by the procedures provided in this manual, have the vehicle inspected by a Yamaha dealer.

5

Before using this vehicle, check the following points:

ITEM	ROUTINE	PAGE
Fuel	<ul style="list-style-type: none"> • Check fuel level in fuel tank, and add recommended fuel if necessary. • Check fuel line for leakage. Correct if necessary. 	4-8, 5-3
Engine oil	<ul style="list-style-type: none"> • Check oil level in engine, and add recommended oil to specified level if necessary. • Check ATV for oil leakage. Correct if necessary. 	5-3, 8-11
Transmission oil	<ul style="list-style-type: none"> • Check ATV for oil leakage. Correct if necessary. 	5-3, 8-14
Front brake	<ul style="list-style-type: none"> • Check operation, and correct if necessary. • Lubricate cable if necessary. • Check lever free play, and adjust if necessary. 	5-3, 8-22, 8-23
Rear brake	<ul style="list-style-type: none"> • Check operation, and correct if necessary. • Lubricate cable if necessary. • Check lever free play, and adjust if necessary. 	5-3, 8-22, 8-25

ITEM	ROUTINE	PAGE
Throttle lever	<ul style="list-style-type: none">• Make sure that operation is smooth. Lubricate cable and lever housing if necessary.• Check lever free play, and adjust if necessary.	5-3, 8-21
Control cables	<ul style="list-style-type: none">• Make sure that operation is smooth. Lubricate if necessary.	8-29
Drive chain	<ul style="list-style-type: none">• Check chain slack, and adjust if necessary.• Check chain condition. Lubricate if necessary.	5-3, 8-26, 8-28
Wheels and tires	<ul style="list-style-type: none">• Check wheel condition, and replace if damaged.• Check tire condition and tread depth. Replace if necessary.• Check air pressure. Correct if necessary.	5-3
Brake levers	<ul style="list-style-type: none">• Make sure that operation is smooth. Lubricate lever pivoting points if necessary.	8-29
Chassis fasteners	<ul style="list-style-type: none">• Make sure that all nuts, bolts and screws are properly tightened.	5-6
Instruments and switches	<ul style="list-style-type: none">• Check operation, and correct if necessary.	5-6

EBU19542

Fuel

Make sure that there is sufficient fuel in the tank. (See page 4-8.)

EBU19561

Engine oil

Make sure that the engine oil is at the specified level. Add oil as necessary. (See page 8-11.)

EBU34490

Transmission oil

Make sure that the transmission oil is at the specified level. Add oil as necessary. (See page 8-14.)

EBU19653

Front and rear brakes

Brake levers

- Check for correct free play in the brake levers. If the free play is incorrect, adjust it. (See pages 8-23 and 8-25.)
- Check operation of the levers. They should move smoothly and there should be a firm feeling when the brake is applied. If not, have the ATV checked by a Yamaha dealer.

Brake operation

Test the brakes at slow speed after starting out to make sure they are working properly. If the brakes do not provide proper braking performance, check the brake shoes for wear. (See page 8-22.)

EBU19762

Throttle lever

Check the operation of the throttle lever. It must open smoothly and spring back to the idle position when released. Have a Yamaha dealer correct if necessary.

EBU19771

Drive chain

Check the condition of the drive chain and check the drive chain slack. Lubricate and adjust the drive chain as necessary. (See page 8-26.)

EBU19795

Tires

Check tire pressure regularly to make sure it is at the recommended specifications. Also check for wear and damage.

Tire pressure

Use the low-pressure tire gauge to check and adjust tire pressures when the tires are cold. Tire pressures must be equal on both sides.

WARNING! Operation of this vehicle with improper tire pressure may cause severe injury or death from loss of control or rollover. Tire pressure below the minimum specified could also cause the tire to dislodge from the rim under severe riding conditions. [EWB02542] Set tire pressures to the following specifications:

Recommended tire pressure:

Front

13.8 kPa (0.14 kgf/cm², 2.0 psi)

Rear

13.8 kPa (0.14 kgf/cm², 2.0 psi)

Minimum tire pressure:

Front

12.4 kPa (0.124 kgf/cm², 1.8 psi)

Rear

12.4 kPa (0.124 kgf/cm², 1.8 psi)

Maximum tire seating pressure:

Front

250 kPa (2.5 kgf/cm², 36 psi)

Rear

250 kPa (2.5 kgf/cm², 36 psi)

The low-pressure tire gauge is included as standard equipment. Make two measurements of the tire pressure and use the second reading. Dust or dirt in the gauge could cause the first reading to be incorrect.

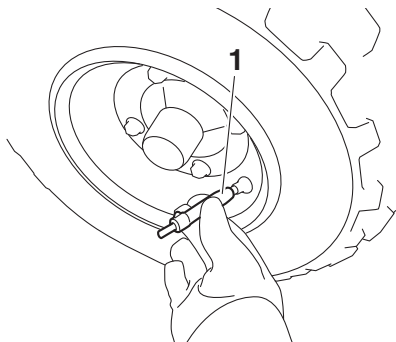

1. Low-pressure tire gauge

Tire wear limit

When the tire groove decreases to 3 mm (0.12 in) due to wear, replace the tire.

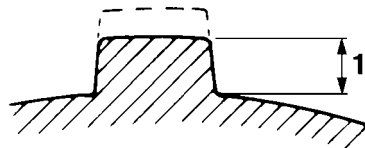

1. Tire wear limit

Tire information

This ATV is equipped with tubeless tires with valves.

EWB02552



Use of improper tires on this ATV may cause loss of control, increasing your risk of an accident.

After extensive tests, only the tires listed below have been approved for this model by Yamaha Motor Co., Ltd.

Front:

Manufacturer/model:

DURO/DI2040

Size:

AT16 x 6.5-7

Type:

Tubeless

Rear:

Manufacturer/model:

DURO/DI2041

Size:

AT16 x 7-7

Type:

Tubeless

EBU33810

Instruments and switches

Check that all instruments and switches are working properly. Correct if necessary.

Aftermarket tires and rims

The tires and rims that came with your ATV were designed to match the performance capabilities and to provide the best combination of handling, braking, and comfort. Other tires, rims, sizes, and combinations may not be appropriate.

EBU19841

Chassis fasteners

Make sure that all nuts, bolts and screws are properly tightened.

OPERATION

Read the Owner's Manual carefully before riding the ATV. If there is a control or function you do not understand, ask your Yamaha dealer.

WARNING

Read the Owner's Manual carefully to become familiar with all controls in order to help prevent any loss of control, which could cause an accident or injury.

Starting a cold engine

NOTICE

See the "Engine break-in" section on page 6-3 prior to operating the engine for the first time.

1. Set the parking brake. (The engine can be started only when the rear brake lever is applied.)
2. Turn the fuel cock to "ON".

3. Turn the key to "ON" and set the engine stop switch to "○".
4. Use the starter (choke) in reference to the figure:

Position (1):

Cold engine start with ambient temperature below 5 °C (40 °F).

Position (2):

Cold engine start with ambient temperature between 0 °C (30 °F) and 30 °C (90 °F).

Position (3):

Cold engine start with ambient temperature above 25 °C (80 °F).

Ambient temp./starter (choke) position

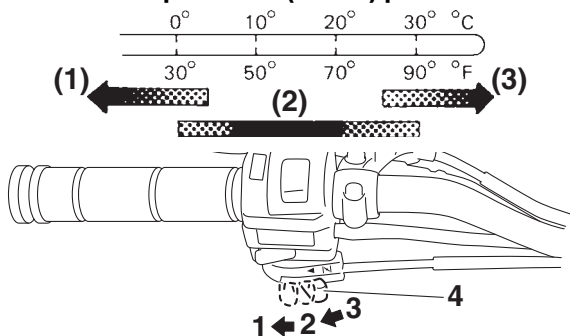

6

1. Fully open
2. Half open
3. Closed
4. Starter (choke)

5. Completely close the throttle lever and start the engine by pushing the start switch.

TIP

- If the engine fails to start, release the start switch, then push it again. Pause a few seconds before the next attempt. Each cranking should be as short as possible to preserve battery energy. Do not crank the engine more than 10 seconds on each attempt.

- If the engine fails to start using the start switch, try using the kickstarter. (See page 4-7.)

6. If the engine is started with the starter (choke) in position (1), the starter (choke) should be returned to position (2) to warm up the engine. If the engine is started with the starter (choke) in position (2), keep the starter (choke) in this position to warm up the engine.
7. Continue warming up the engine until it idles smoothly, then return the starter (choke) to position (3) before riding.

TIP

The engine is warm when it responds quickly to the throttle with the starter (choke) turned off.

8. Release the parking brake.

ECB00164

NOTICE

For maximum engine life, never accelerate hard when the engine is cold!

Starting a warm engine

Follow the same procedure as for starting a cold engine, with the exception that the starter (choke) is not required when the engine is warm. Instead, start the engine with the throttle slightly open.

Engine break-in

TIP

- For ATVs equipped with an odometer or an hour meter, follow the figures given in km (mi) or the figures given in hours.
- For ATVs not equipped with an odometer or hour meter, follow the figures given in hours.

There is never a more important period in the life of your engine than the first 240 km (150 mi) or 20 hours of riding. For this reason, you should read the following material carefully.

Since the engine is brand new, do not put an excessive load on it for the first 240 km (150 mi) or 20 hours. The various parts in the engine wear and polish themselves to the correct operating clearances. During this period, prolonged full-throttle operation or any condition that might result in engine overheating must be avoided.

0–120 km (0–75 mi) or 0–10 hours

Avoid prolonged operation above 1/2 throttle. Vary the speed of the ATV regularly. Do not operate it at one set throttle position.

120–240 km (75–150 mi) or 10–20 hours

Avoid prolonged operation above 3/4 throttle. Rev the engine freely, but do not use full throttle at any time.

240 km (150 mi) or 20 hours and beyond

The ATV can now be operated normally.

NOTICE

If any engine trouble should occur during the engine break-in period, immediately have a Yamaha dealer check the ATV.

Parking

When parking the ATV, apply the rear brake lever, stop the engine, apply the parking brake, and then turn the fuel cock to “OFF”.

Never park the ATV on hills that are too steep to walk up easily.

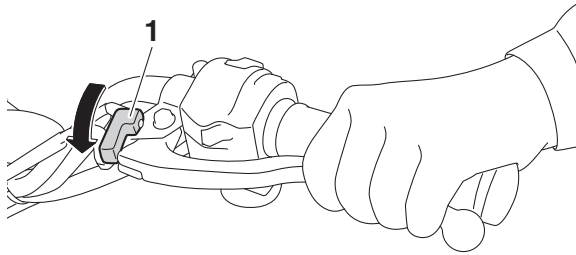

1. Bring the ATV to a stop by applying the brakes.
2. Stop the engine.
3. With the rear brake lever applied, apply the parking brake, and then slowly release the rear brake lever.
4. Turn the fuel cock to “OFF”.

6

1. Parking brake lock plate

EBU36380

Parking on a slope

EWB04130



WARNING

Avoid parking on hills or other inclines. Parking on a hill or other incline could cause the ATV to roll out of control, increasing the chance of an accident. If you must park on an incline, place the ATV transversely across the incline, stop the engine, apply the parking brake, and then block the front and rear wheels with rocks or other objects.

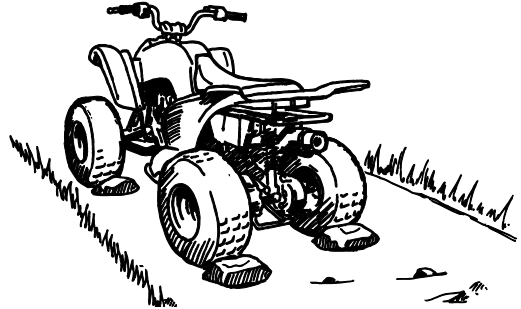

Accessories and loading

Genuine Yamaha Accessories

Choosing accessories for your ATV is an important decision. Genuine Yamaha Accessories, which are available only from a Yamaha dealer, have been designed, tested, and approved by Yamaha for use on your ATV. Many companies with no connection to Yamaha manufacture parts and accessories or offer other modifications for Yamaha vehicles. Yamaha is not in a position to test the products that these aftermarket companies produce. Therefore, Yamaha can neither endorse nor recommend the use of accessories not sold by Yamaha or modifications not specifically recommended by Yamaha, even if sold and installed by a Yamaha dealer.

Aftermarket parts, accessories, and modifications

While you may find aftermarket products similar in design and quality to genuine Yamaha Accessories, recognize that some aftermarket accessories or modifications are not suitable because of potential safety hazards to you or others. Installing

aftermarket products or having other modifications performed to your ATV that change any of the vehicle's design or operation characteristics can put you and others at greater risk of serious injury or death. You are responsible for injuries related to changes in the vehicle.

Keep the following in mind when considering an accessory or operating an ATV which has accessories.

- Accessories should be rigidly and securely mounted. An accessory which can shift position or come off while you are riding could affect your ability to control the ATV.
- Do not mount an accessory where it could interfere with your ability to control the ATV. Examples include (but are not limited to) a heavy or bulky object attached to the handlebars which could make steering difficult, an accessory that limits your ability to move around on the seat, or one that limits your view.
- Use extra caution when riding an ATV with accessories. The ATV may handle differently than it does without accessories.



Never exceed the stated load capacity for this ATV. Overloading this ATV or carrying or towing cargo improperly could cause changes in ATV handling which could lead to an accident. Cargo should be properly distributed and securely attached. Reduce speed when carrying cargo or pulling a trailer. Allow greater distance for braking.

6

As originally equipped, this ATV is not designed to carry cargo or tow a trailer. If you choose to add accessories so that you can carry cargo or tow a trailer, you must use common sense and good judgment as the stability and handling of an ATV can be changed. When adding accessories, keep the following points in mind:

- Never exceed the weight limits shown. An overloaded ATV can be unstable.

MAXIMUM LOADING LIMIT

ATV loading limit (total weight of rider, cargo, accessories, and tongue weight):

41.0 kg (90 lb)

- If you are carrying cargo and towing a trailer, include the tongue weight in the maximum ATV load limit.
- Load cargo on the carriers as close to the center of the ATV as possible. Put cargo at the rear of the front carrier, at the front of the rear carrier, and center it.
- Tie down cargo securely to the carriers. Make sure cargo in the trailer cannot move around. A shifting load can cause an accident.
- Make sure the load does not interfere with controls or your ability to see where you are going.
- Ride more slowly than you would without a load. The more weight you carry, the slower you should go.
- Allow more braking distance. A heavier ATV takes longer to stop.
- Avoid making sharp turns unless at very slow speeds.
- Avoid hills and rough terrain. Choose terrain carefully. Added weight affects the stability and handling of the ATV.

RIDING YOUR ATV

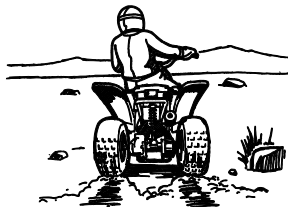
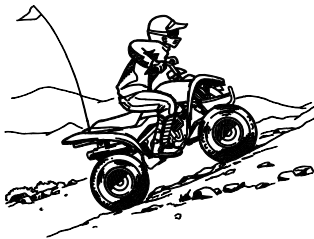

GETTING TO KNOW YOUR ATV

This ATV is intended for recreational use by young operators under adult supervision. This section, “Riding your ATV”, provides general riding instructions which are appropriate for all types of riding. Riding your ATV requires special skills acquired through practice over a period of time. Take the time to learn the basic techniques well before attempting more difficult maneuvers.

Riding your new ATV can be a very enjoyable activity, providing you with hours of pleasure. But it is essential to familiarize yourself with the operation of the ATV to achieve the skill necessary to enjoy riding safely. Before you begin to ride, be sure you have read this manual completely and understand how to operate all of the ATV’s controls. Pay particular attention to the safety information on pages 2-1 to 2-8 and all notice and warning labels on the vehicle.

RIDE WITH CARE AND GOOD JUDGMENT

Beginning riders should get training from a certified instructor.

EWB01382

WARNING

- **Do not operate this ATV or allow anyone else to operate it without proper instruction. The risk of an accident is greatly increased if the operator does not know how to operate the ATV properly in different situations and on different types of terrain.**
- **Do not operate this ATV at speeds too fast for your skills or the conditions, as this increases your chances of losing control of the ATV and an accident. Always go at a speed that is proper for the terrain, visibility and operating conditions, and your experience.**

Riding your ATV requires skills acquired through practice over a period of time.

Become familiar with riding this ATV by riding at slow speeds first, even if you have experience riding other ATVs. Do not attempt to operate it at higher performance levels until you are familiar with this ATV’s handling and performance charac-

teristics. Take the time to learn the basic techniques well before attempting more difficult maneuvers.

Not recommended for children under 6 years of age.

EWB01751

⚠ WARNING

A child under 6 should never operate an ATV with engine size greater than 50 cc. Use by children of ATVs that are not recommended for their age can lead to severe injury or death of the child.



This ATV is designed to carry the operator only – passengers prohibited.

The long seat is to allow the operator to shift position as needed during operation. It is not for carrying passengers. **WARNING! Never carry a passenger. Carrying a passenger on this ATV greatly reduces your ability to balance and control this ATV. You could have an accident, resulting in severe injury or death to you and/or your passenger.** [EWB01402]



Apparel

Always wear the following to reduce risk of injury in an accident:

- Approved motorcycle helmet that fits properly
- Eye protection (goggles, helmet face shield, or protective eyewear)
- Over-the-ankle boots, gloves, long-sleeved shirt or jacket, and long pants

An approved helmet and other personal protective equipment can reduce the severity of injuries in an accident. **WARNING! Operating without an approved motorcycle helmet increases your chances of a severe head injury or death in the event of an accident.** [EWB01412]

7

Wear eye protection when operating your ATV to reduce the risk of a serious accident or injury. Eye protection, such as a face shield or goggles, may reduce the risk of foreign material getting in your eyes and help prevent loss of vision. **WARNING! Operating without eye protection can result in an accident and increases your chances of a severe injury in the event of an accident.**

[EWB02612]

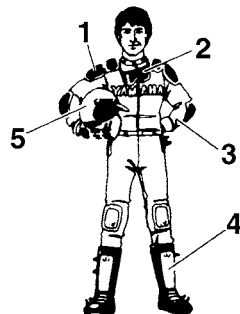

1. Protective clothing
2. Goggles
3. Gloves
4. Boots
5. Helmet

Do not operate after or while consuming alcohol or drugs.

The operator's performance capability is reduced by the influence of alcohol or drugs. Consuming alcohol or drugs could seriously affect your judgment, cause you to react more slowly, and affect your balance and perception. **WARNING! Never consume alcohol or drugs before or while driving this ATV. You increase your chance of an accident.** [EWB01422]



Pre-operation checks

Always inspect your ATV each time you use it to make sure the ATV is in safe operating condition. Perform the pre-operation checks listed on page 5-1. Always follow the inspection and maintenance procedures and schedules described in the Owner's Manual. **WARNING! Failure to inspect the ATV before riding it or failure to maintain it properly increases the possibility of an accident and equipment damage.** [EWB01433]

Speed limiter

For beginning riders, riders less experienced with this model, or whenever limited speed is desirable, the throttle lever housing is equipped with a

vehicle speed limiter. The speed limiter keeps the throttle from fully opening, even when the throttle lever is pushed to the maximum. Turning in the adjusting screw limits the maximum engine power available and decreases the maximum speed of the ATV. Turning in the adjusting screw decreases top speed, and turning it out increases top speed. (See page 4-3.)

This model also has an engine speed limiter plate to limit the amount of engine power available. Yamaha recommends that all beginning riders start off with the engine speed limiter plate installed and the vehicle speed limiter adjusting screw turned in to limit the amount of speed available while they learn. The vehicle speed limiter may be gradually adjusted to increase maximum speed as the beginner becomes more familiar with operating the ATV. Parents should decide when to adjust the ATV for more power as their youngster's riding skills improve. Once the ATV rider can operate with skill at the top speed permitted by adjusting the vehicle speed limiter alone, the engine speed limiter plate can be removed. Since removal of this plate will result in a significant increase in power, turn the vehicle speed limiter

adjusting screw back in again and adjust it out in stages as you did before. For engine speed limiter plate removal instructions, see page 4-5.

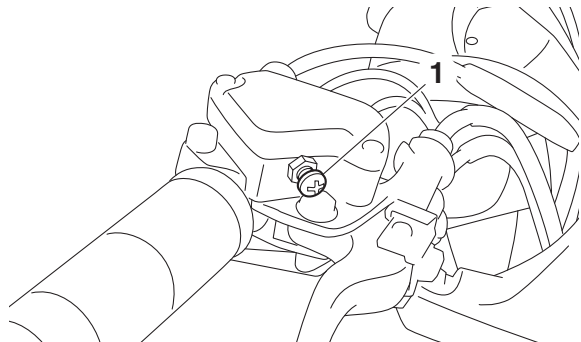

7

1. Adjusting screw

Loading and accessories

EWB00973



WARNING

Improper loading or towing can increase the risk of loss of control, an overturn, or other accident. To reduce the risk of an accident:

- **Do not exceed the maximum loading limits for the vehicle (see “MAXIMUM LOADING LIMIT” below or vehicle labeling).**

- **Make sure the load does not interfere with your control or ability to see where you are going.**
- **Reduce speed and allow more room to stop. A heavier vehicle takes longer to stop.**
- **Avoid hills and rough terrain. Choose terrain carefully. Use extreme caution when towing or carrying a load on inclines.**
- **Turn gradually and go slowly.**

As originally equipped, this ATV is not designed to carry cargo or tow a trailer. If you choose to add accessories to carry cargo, you must use common sense and good judgment.

Use extra caution when riding the ATV with additional loads, such as accessories or cargo. The ATV's handling may be adversely affected. Reduce your speed when adding additional loads.

MAXIMUM LOADING LIMIT

ATV loading limit (total weight of cargo, rider, accessories, and tongue weight):
41.0 kg (90 lb)

During operation

Always keep your feet on the footboards during operation; otherwise, they may contact the rear wheels. **WARNING! Removing even one hand or foot can reduce your ability to control the ATV or could cause you to lose your balance and fall off of the ATV. If you remove a foot from a footboard, your foot or leg may come into contact with the rear wheels, which could injure you or cause an accident.** [EWB01472]

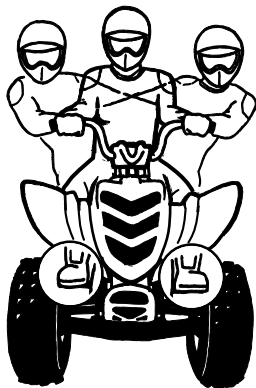

Avoid wheelies and jumping. **WARNING! Attempting wheelies, jumps, and other stunts increases the chance of an accident, including**

an overturn. Never attempt stunts, such as wheelies or jumps. Don't try to show off.

[EWB01482]

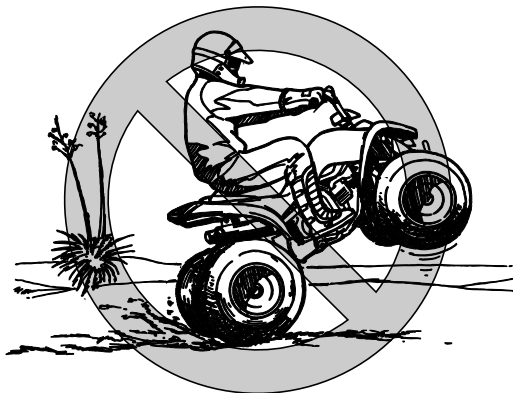

Modifications and accessories

Never modify this ATV through improper installation or use of accessories or other modification. All parts and accessories added to this ATV should be genuine Yamaha or equivalent components designed for use on this ATV and should be installed and used according to instructions. If you have questions, consult an authorized ATV dealer. **WARNING! Operating this ATV with improper**

modifications may cause changes in handling which in some situations could lead to an accident. [EWB01492]

Exhaust system

EWB01502

⚠ WARNING

- **Dry grass or brush or other combustible material accumulated around the engine area could catch fire. Do not operate, idle, or park the ATV in dry grass or other dry ground cover. Keep the engine area free of dry grass, brush, or other combustible material.**
- **Someone touching the exhaust system during or after operation could be burned. Do not touch the hot exhaust system. Do not park the ATV in a place where others might be likely to touch it.**

The muffler and other engine parts become extremely hot during operation and remain hot after the engine has stopped. To reduce the risk of fire during operation or after leaving the ATV, do not let brush, grass and other materials collect under the vehicle, near the muffler or exhaust pipe, or next to other hot parts. Check under the vehicle after operating in areas where combustible mate-

rials may have collected. Do not idle or park the vehicle in long dry grass or other dry ground cover.

To prevent burns, avoid touching the exhaust system. Park the ATV in a place where pedestrians or children are not likely to touch it.

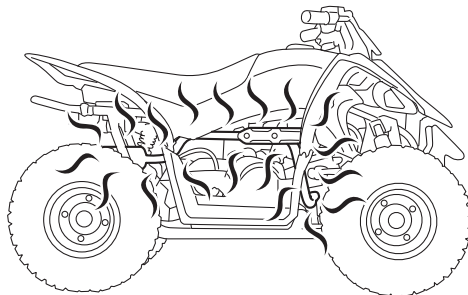

BE CAREFUL WHERE YOU RIDE

This ATV is designed for use on unpaved surfaces only. **WARNING! Paved surfaces may seriously affect handling and control of the ATV, and may cause the ATV to go out of control. Always avoid paved surfaces, including sidewalks, driveways, parking lots and streets.** [EWB01512]

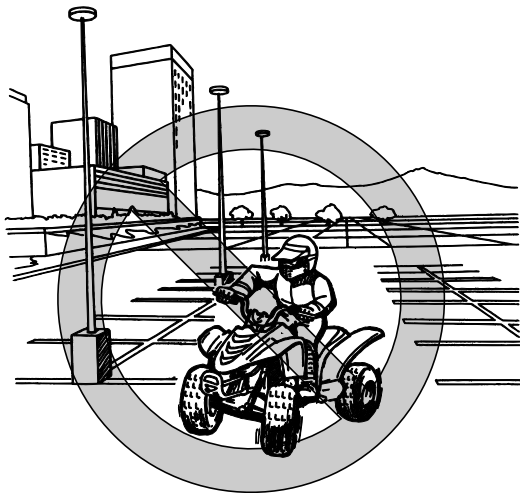

While riding on unpaved public streets or roads may be legal in your area, such operation can increase the risk of collision with other vehicles.

Watch carefully for other vehicles. Make sure you know your country's laws and regulations before you ride on unpaved public streets or roads. Do not ride on any paved public street, road or motorway. **WARNING! Never operate this ATV on any paved street, paved road or motorway. You can collide with another vehicle.** [EWB01522]

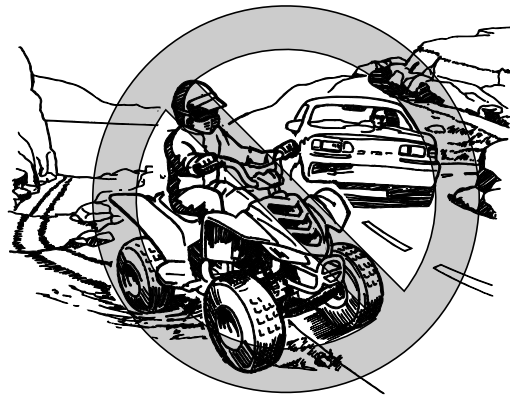

Know the terrain where you ride. Ride cautiously in unfamiliar areas. Stay alert for holes, rocks, or roots in the terrain, and other hidden hazards which may cause the ATV to upset. **WARNING! The ATV could go out of control if you do not have enough time to react to hidden rocks,**

bumps, or holes. Go slowly and be extra careful when operating on unfamiliar terrain. Always be alert to changing terrain conditions when operating the ATV. [EWB01532]

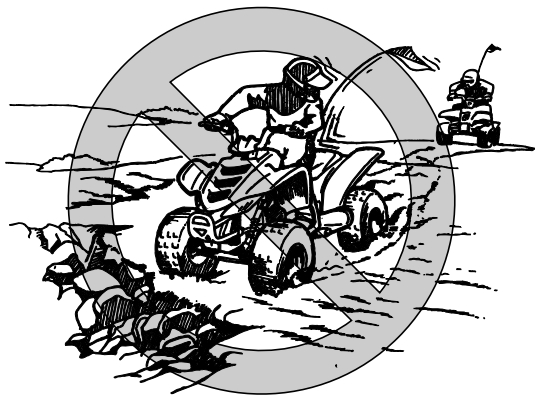

7

Do not operate on rough, slippery, or loose terrain until you have learned and practiced the skills necessary to control the ATV on such terrain. Always be especially cautious on these kinds of terrain. **WARNING! Failure to use extra care when operating on excessively rough, slippery, or loose terrain could cause loss of traction or ATV control, which could result in an accident, including an overturn.** [EWB01542]

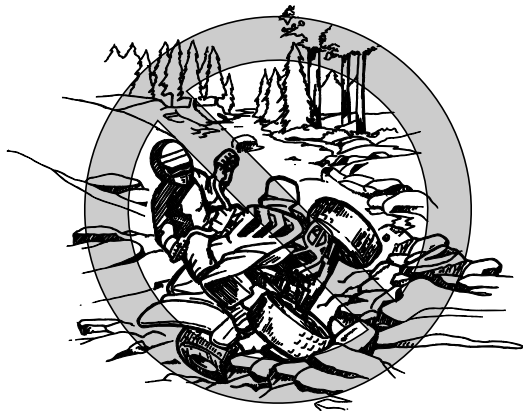

When riding in an area where you might not easily be seen, such as desert terrain, mount a caution flag on the ATV. DO NOT use the flag pole bracket as a trailer hitch. **WARNING! You could collide with another vehicle if operating in areas where you cannot easily be seen. Mount a caution flag on the ATV to make you more visible. Watch carefully for other vehicles.** [EWB01552]

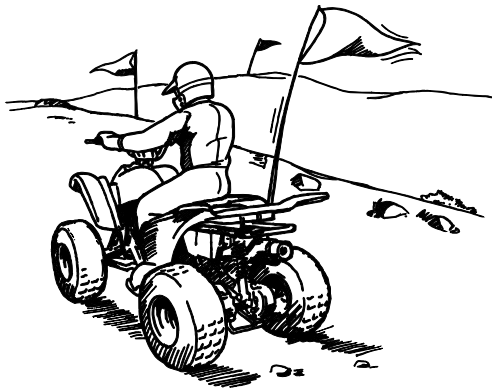

Do not ride in areas posted “no trespassing”.
Do not ride on private property without getting permission.

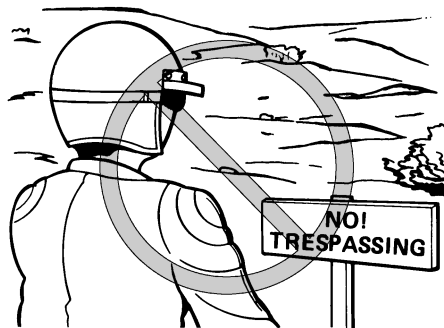

Select a large, flat, unpaved area to become familiar with your ATV. Make sure that this area is free of obstacles and other riders. You should practice control of the throttle, brakes, and turning techniques in this area before trying more difficult terrain.

Set the parking brake and follow the instruction on page 6-1 to start the engine. Once it has warmed up you are ready to begin riding your ATV. Remember that the engine and exhaust pipe will be hot when riding and afterwards; do not allow skin or clothing to come in contact with these components.

With the engine idling, release the parking brake. Apply the throttle slowly and smoothly. You will start to accelerate. If the throttle is applied too

abruptly, the vehicle may lurch forward or the front wheels may lift off the ground, resulting in a loss of directional control. Avoid higher speeds until you are thoroughly familiar with the operation of your ATV.

When slowing down or stopping, release the throttle and apply the brakes smoothly and evenly. Improper use of the brakes can cause the tires to lose traction, reducing control and increasing the possibility of an accident.

TURNING YOUR ATV

EWB01772



7

Always follow proper procedures for turning as described in this Owner's Manual. Practice turning at low speeds before attempting to turn at faster speeds. Do not turn at speeds too fast for your skills or the conditions. ATV could go out of control, causing a collision or overturn.

To achieve maximum traction on unpaved surfaces, the two rear wheels turn together at the same speed. Therefore, unless the wheel on the inside of the turn is allowed to slip or lose some traction, the ATV will resist turning. A special turning tech-

nique must be used to allow the ATV to make turns quickly and easily. It is essential that this skill be learned first at low speed.

As you approach a curve, slow down and begin to turn the handlebars in the desired direction. As you do so, put your weight on the footboard to the outside of the turn (opposite your desired direction) and lean your upper body into the turn. Use the throttle to maintain an even speed through the turn. This maneuver will let the wheel on the inside of the turn slip slightly, allowing the ATV to make the turn properly.



1. Lean towards inside of turn.
2. Support your weight on the outer footboard.

This procedure should be practiced at slow speed many times in a large unpaved area with no obstacles. If an incorrect technique is used, your ATV may continue to go straight. If the ATV doesn't turn, come to a stop and then practice the procedure again. If the riding surface is slippery or loose, it may help to position more of your weight over the front wheels by moving forward on the seat.

Once you have learned this technique, you should be able to perform it at higher speeds or in tighter curves.

Improper riding procedures such as abrupt throttle changes, excessive braking, incorrect body movements, or too much speed for the sharpness of the turn may cause the ATV to tip. If the ATV begins to tip over to the outside while negotiating a turn, lean more to the inside. It may also be necessary to gradually let off on the throttle and steer to the outside of the turn to avoid tipping over.

Remember: Avoid higher speeds until you are thoroughly familiar with the operation of your ATV.

CLIMBING UPHILL

EWB01672



Climbing hills improperly can cause overturns or loss of control. Use proper riding techniques described in this Owner's Manual.

- **Never operate the ATV on hills too steep for the ATV or for your abilities. The ATV can overturn more easily on extremely steep hills than on level surfaces or small hills.**
- **Always check the terrain carefully before you start up any hill. Never climb hills with excessively slippery or loose surfaces.**

- Shift your weight forward.
 - Never open the throttle suddenly. The ATV could flip over backwards.
 - Never go over the top of any hill at high speed. An obstacle, a sharp drop, or another vehicle or person could be on the other side of the hill.
 - Never attempt to turn the ATV around on any hill until you have mastered the turning technique as described in the Owner's Manual on level ground. Be very careful when turning on any hill.
 - Avoid crossing the side of a steep hill if possible. When crossing the side of a hill, shift your weight to the uphill side of the ATV.
-



OK



Do not attempt to climb hills until you have mastered basic maneuvers on flat ground. Always check the terrain carefully before attempting any hill. In all cases avoid inclines with slippery or loose surfaces, or obstacles that might cause you to lose control.

To climb a hill, you need traction, momentum, and steady throttle. Travel fast enough to maintain momentum, but not so fast that you cannot react to changes in the terrain as you climb.

It is important when climbing a hill to make sure that your weight is transferred forward on the ATV. This can be accomplished by leaning forward and,

on steeper inclines, standing on the footboards and leaning forward over the handlebars. Whenever possible, ride straight up hills.

Slow down when you reach the crest of the hill if you cannot see clearly what is on the other side – there could be another person, an obstacle, or a sharp drop-off. Use common sense and remember that some hills are too steep for you to climb or descend.

If you are climbing a hill and you find that you have not properly judged your ability to make it to the top, you should turn the ATV around while you still have forward motion (provided you have the room to do so) and go down the hill.

If your ATV has stalled or stopped and you believe you can continue up the hill, restart carefully to make sure you do not lift the front wheels which could cause you to lose control. If you are unable to continue up the hill, dismount the ATV on the uphill side. Physically turn the ATV around and then descend the hill.

If you start to roll backwards, DO NOT apply the rear brake, and apply the front brake gradually. The ATV could easily tip over backwards. When fully stopped, apply the rear brake as well, and then lock the parking brake. Dismount the ATV im-

mediately on the uphill side or to a side if pointed straight uphill. Turn the ATV around and remount, following the procedure described in the Owner's Manual. **WARNING! Stalling, rolling backwards or improperly dismounting while climbing a hill could result in ATV overturning. If you cannot control the ATV, dismount immediately on the uphill side.** [EWB01803]

RIDING DOWNHILL

EWB01132

WARNING

Going down a hill improperly could cause overturns or loss of control. Always follow proper procedures for going down hills as described in this Owner's Manual.

- Always check the terrain carefully before you start down any hill.
- Never operate the ATV on hills too steep for the ATV or for your abilities. The ATV can overturn more easily on extremely steep hills than on level surfaces or small hills.
- Shift your weight backward and to the up side of the hill.
- Never go down a hill at high speed.
- Avoid going down a hill at an angle that would cause the ATV to lean sharply to one side. Go straight down the hill where possible.
- Improper braking can cause the wheels on the uphill side to come off the ground or cause loss of traction. Gradually apply only the rear brake when going downhill.

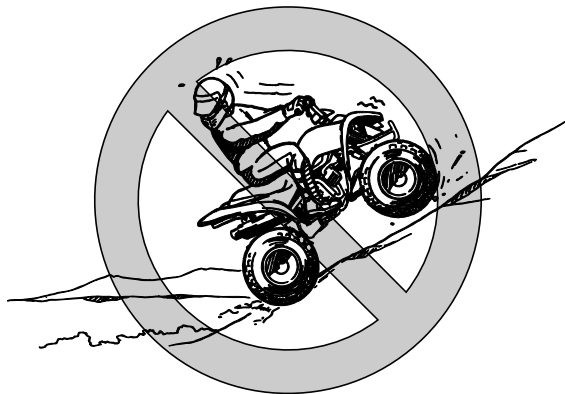

When riding your ATV downhill, shift your weight as far to the rear and uphill side of the ATV as possible. Move back on the seat and sit with your arms straight. Allow the engine compression to do most of the braking for you.

Use caution while descending a hill with loose or slippery surfaces. Braking ability and traction may be adversely affected by these surfaces. Improper braking may also cause a loss of traction. Gradually apply only the rear brake.

Whenever possible, ride your ATV straight downhill. Avoid sharp angles which could allow the ATV to tip or roll over. Carefully choose your path and ride no faster than you will be able to react to obstacles which may appear.

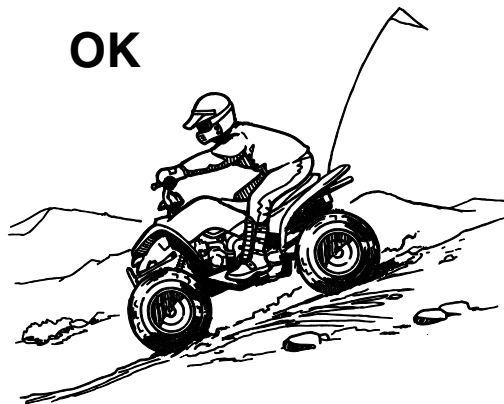

CROSSING A SLOPE

EWB01633



WARNING

Improperly crossing hills or turning on hills could cause loss of control or cause the ATV to overturn.

- Always follow proper procedures as described in the Owner's Manual.
- Avoid hills with excessively slippery or loose surfaces.
- Avoid crossing the side of a steep hill.
- Shift your weight to the uphill side of the ATV.

- **Never attempt to turn the ATV around on any hill until you have mastered the turning technique as described in the Owner's Manual on level ground. Be very careful when turning on any hill.**

Traversing a sloping surface on your ATV requires you to properly position your weight to maintain proper balance. Be sure that you have learned the basic riding skills on flat ground before attempting to cross a sloping surface. Avoid slopes with slippery surfaces or rough terrain that may upset your balance.

7

As you travel across a slope, lean your body in the uphill direction. It may be necessary to correct the steering when riding on loose surfaces by pointing the front wheels slightly uphill. When riding on slopes, be sure not to make sharp turns either up or down hill.

If your ATV does begin to tip over, gradually steer in the downhill direction if there are no obstacles in your path. As you regain proper balance, gradually steer again in the direction you wish to travel.



CROSSING THROUGH SHALLOW WATER

EWB01642

⚠ WARNING

Operating this vehicle through deep or fast-flowing water can lead to loss of control or an overturn. To reduce your risk of drowning or other injuries, use care when crossing through water. Never operate this ATV water deeper than the depth specified in your Owner's Manual, as tires may float, increasing the risk of an overturn.

The ATV can be used to cross slow moving, shallow water of up to a maximum of 11 cm (4 in) in depth. Before entering the water, choose your path carefully. Enter where there is no sharp drop off, and avoid rocks or other obstacles which may be slippery or upset the ATV. Drive slowly and carefully.

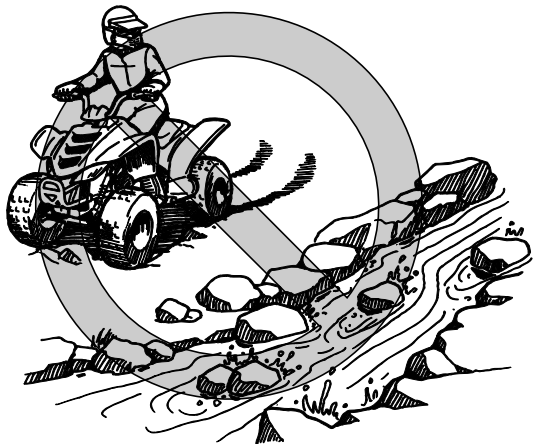

Test your brakes after leaving the water. If necessary, apply them several times to let friction dry out the linings. Do not continue to ride your ATV without verifying that you have regained proper

braking ability. **WARNING! Wet brakes may have reduced stopping ability, which could cause loss of control.** [EWB02622]

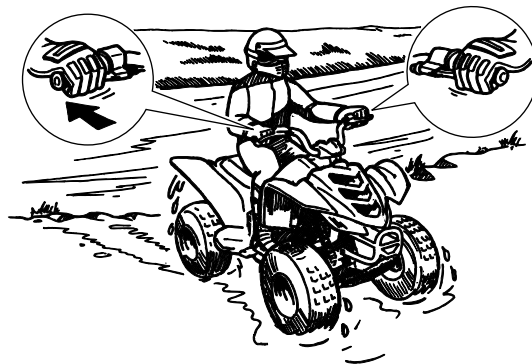

After riding your ATV in water, be sure to drain the trapped water by removing the check hose at the bottom of the air filter case. **NOTICE: Undrained water can cause damage or improper operation.** [ECB00842]

Wash the ATV in fresh water if it has been operated in salt water or muddy conditions.

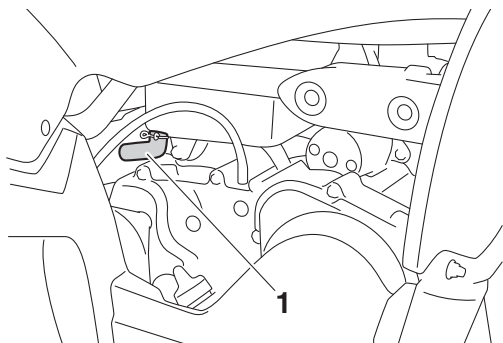

1. Air filter case check hose

7 RIDING OVER ROUGH TERRAIN

EWB01652

⚠ WARNING

Riding improperly over obstacles could cause loss of control or a collision. Before operating in a new area, check for obstacles. Never attempt to ride over large obstacles, such as large rocks or fallen trees. When you go over obstacles, always follow proper procedures as described in the Owner's Manual.

Riding over rough terrain should be done with caution. Look out for obstacles which could cause damage to the ATV or could lead to an upset or

accident. Be sure to keep your feet firmly mounted on the footboards at all times. Avoid jumping the ATV as loss of control and damage to the ATV may result.

SLIDING AND SKIDDING

EWB01663

⚠ WARNING

Skidding or sliding improperly may cause you to lose control of this ATV. You may also regain traction unexpectedly, which may cause the ATV to overturn.

- Learn to safely control skidding or sliding by practicing at low speeds and on level, smooth terrain.
- On extremely slippery surfaces, such as ice, go slowly and be very cautious in order to reduce the chance of skidding or sliding out of control.

Care should be used when riding on loose or slippery surfaces since the ATV may slide. If unexpected and uncorrected, sliding could lead to an accident.

To reduce the tendency for the front wheels to slide in loose or slippery conditions, positioning your weight over the front wheels will sometimes help.

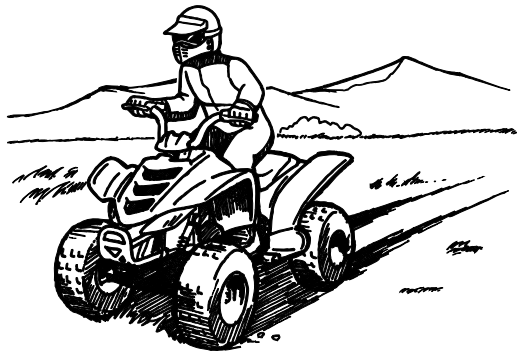

If the rear wheels of your ATV start to slide sideways, control can usually be regained (if there is room to do so) by steering in the direction of the slide. Applying the brakes or accelerating is not recommended until you have corrected the slide.



With practice, over a period of time, skill at controlled sliding can be developed. The terrain should be chosen carefully before attempting such maneuvers, since both stability and control are reduced. Bear in mind that sliding maneuvers should always be avoided on extremely slippery surfaces such as ice, since all control may be lost.

WHAT TO DO IF...

This section is designed to be a reference guide only. Be sure to read each section on riding techniques completely.

WHAT TO DO...

- If your ATV doesn't turn when you want it to:
Bring the ATV to a stop and practice the turning maneuvers again. Be sure you are putting your weight on the footboard to the outside of the turn. Position your weight over the front wheels for better control. (See page 7-12.)
- If your ATV begins to tip while turning:
Lean more into the turn to regain balance. If necessary, gradually let off the throttle and/or steer to the outside of the turn. (See page 7-12.)
- If your ATV starts to slide sideways:
Steer in the direction of the slide if you have the room. Applying the brakes or accelerating is not recommended until you have corrected the slide. (See page 7-20.)
- If your ATV can't make it up a hill you are trying to climb:
Turn the ATV around if you still have forward speed. If not, stop, dismount on the uphill side of the ATV and physically turn the ATV around. If the ATV starts to slip backwards, **DO NOT USE THE REAR BRAKE** – the ATV may tip over on top of you. Dismount the ATV on the uphill side. (See page 7-13.)

- If your ATV is traversing a sloping surface:
Be sure to ride with your weight positioned towards the uphill side of the ATV to maintain proper balance. If the ATV starts to tip, steer down the hill (if there are no obstacles in your way) to regain balance. If you discover that the ATV is going to tip over, dismount on the uphill side. (See page 7-17.)
- If your ATV encounters shallow water:
Ride slowly and carefully through slow moving water, watching for obstacles. Be sure to let water drain from the ATV and **CHECK YOUR BRAKES FOR PROPER OPERATION** when you come out of the water. Do not continue to ride your ATV until you have regained adequate braking ability. (See page 7-18.)

PERIODIC MAINTENANCE AND ADJUSTMENT

Periodic inspection, adjustment, and lubrication will keep your vehicle in the safest and most efficient condition possible. Safety is an obligation of the vehicle owner/operator. The most important points of vehicle inspection, adjustment, and lubrication are explained on the following pages.

WARNING

Failure to properly maintain the vehicle or performing maintenance activities incorrectly may increase your risk of injury or death during service or while using the vehicle. If you are not familiar with vehicle service, have a Yamaha dealer perform the service.

WARNING

Turn off the engine when performing maintenance unless otherwise specified.

- **A running engine has moving parts that can catch on body parts or clothing and electrical parts that can cause shocks or fires.**

- **Running the engine while servicing can lead to eye injury, burns, fire, or carbon monoxide poisoning - possibly leading to death. See page 2-8 for more information about carbon monoxide.**

WARNING

Brake discs, calipers, drums, and linings can become very hot during use. To avoid possible burns, let brake components cool before touching them.

The intervals given in the periodic maintenance charts should be considered as a general guide under normal riding conditions. However, DEPENDING ON THE WEATHER, TERRAIN, GEOGRAPHICAL LOCATION, AND INDIVIDUAL USE, THE MAINTENANCE INTERVALS MAY NEED TO BE SHORTENED.

Owner's manual and tool kit

Be sure to put this owner's manual in the plastic bag and always carry it along with the owner's tool kit on the bottom of the seat.

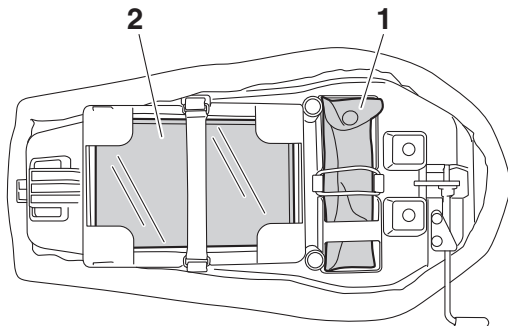
**8**

1. Owner's tool kit
2. Owner's manual

The service information included in this manual and the tools provided in the owner's tool kit are intended to assist you in the performance of preventive maintenance and minor repairs. However, additional tools such as a torque wrench may be necessary to perform certain maintenance work correctly.

TIP _____

- There is a low-pressure tire gauge located in the tool kit.
 - If you do not have the tools or experience required for a particular job, have a Yamaha dealer perform it for you.
-

Periodic maintenance chart for the emission control system

TIP

- For ATVs not equipped with an odometer or an hour meter, follow the month maintenance intervals.
- For ATVs equipped with an odometer or an hour meter, follow the km (mi) or hours maintenance intervals. However, keep in mind that if the ATV isn't used for a long period of time, the month maintenance intervals should still be followed.
- Items marked with an asterisk should be performed by a Yamaha dealer as they require special tools, data and technical skills.

NO.	ITEM	CHECK OR MAINTENANCE JOB	Whichever comes first ⇒	INITIAL			EVERY		
				month	1	3	6	6	12
				km (mi)	240 (150)	1300 (800)	2500 (1600)	2500 (1600)	5000 (3200)
hours	20	80	160	160	320				
1	* Fuel line	• Check fuel hoses for cracks or other damage, and replace if necessary.				√	√	√	
2	Spark plug	• Check condition and clean, regap, or replace if necessary.		√	√	√	√	√	
3	* Valves	• Check valve clearance and adjust if necessary.		√		√	√	√	
4	* Carburetor	• Check starter (choke) operation and correct if necessary. • Check engine idling speed and adjust if necessary.		√		√	√	√	
5	* Crankcase breather system	• Check breather hose for cracks or other damage, and replace if necessary.				√	√	√	

NO.	ITEM	CHECK OR MAINTENANCE JOB	Whichever comes first ⇒	INITIAL			EVERY		
				month	1	3	6	6	12
				km (mi)	240 (150)	1300 (800)	2500 (1600)	2500 (1600)	5000 (3200)
				hours	20	80	160	160	320
6	*	Exhaust system	<ul style="list-style-type: none"> • Check for leakage and replace gasket(s) if necessary. • Check for looseness and tighten all screw clamps and joints if necessary. 			√	√	√	
7		Spark arrester	<ul style="list-style-type: none"> • Clean. 			√	√	√	
8	*	Air induction system	<ul style="list-style-type: none"> • Check the air cut-off valve, reed valve, and hose for damage. • Check condition and clean or replace if necessary. 			√	√	√	

General maintenance and lubrication chart

TIP

- For ATVs not equipped with an odometer or an hour meter, follow the month maintenance intervals.
- For ATVs equipped with an odometer or an hour meter, follow the km (mi) or hours maintenance intervals. However, keep in mind that if the ATV isn't used for a long period of time, the month maintenance intervals should still be followed.
- Items marked with an asterisk should be performed by a Yamaha dealer as they require special tools, data and technical skills.

NO.	ITEM	CHECK OR MAINTENANCE JOB	Whichever comes first ⇒	INITIAL			EVERY		
				month	1	3	6	6	12
				km (mi)	240 (150)	1300 (800)	2500 (1600)	2500 (1600)	5000 (3200)
hours	20	80	160	160	320				
1	Air filter element	• Clean and replace if necessary.		Every 20–40 hours (more often in wet or dusty areas)					
2	Air filter check hose	• Clean.		√	√	√	√	√	
3	* Front brake	• Check operation and correct if necessary. • Check brake lever free play and adjust if necessary.		√	√	√	√	√	
		• Replace brake shoes.		Whenever worn to the limit					
4	* Rear brake	• Check operation and correct if necessary. • Check brake lever free play and adjust if necessary.		√	√	√	√	√	
		• Replace brake shoes.		Whenever worn to the limit					

NO.	ITEM	CHECK OR MAINTENANCE JOB	Whichever comes first ⇒	INITIAL			EVERY		
				month	1	3	6	6	12
				km (mi)	240 (150)	1300 (800)	2500 (1600)	2500 (1600)	5000 (3200)
				hours	20	80	160	160	320
5	*	Wheels	<ul style="list-style-type: none"> • Check runout and for damage, and replace if necessary. 	√		√	√	√	
6	*	Tires	<ul style="list-style-type: none"> • Check tread depth and for damage, and replace if necessary. • Check air pressure and balance, and correct if necessary. 	√		√	√	√	
7	*	Wheel hub bearings	<ul style="list-style-type: none"> • Check for looseness or damage, and replace if necessary. 	√		√	√	√	
8	*	Front arm pivots	<ul style="list-style-type: none"> • Lubricate with lithium-soap-based grease. 			√	√	√	
9		Drive chain	<ul style="list-style-type: none"> • Check chain slack and adjust if necessary. • Check rear wheel alignment and correct if necessary. • Clean and lubricate. 	√	√	√	√	√	
10	*	V-belt	<ul style="list-style-type: none"> • Check for wear, cracks or other damage, and replace if necessary. 	√		√	√	√	
11	*	Chassis fasteners	<ul style="list-style-type: none"> • Make sure that all nuts, bolts, and screws are properly tightened. 	√	√	√	√	√	
12	*	Shock absorber assemblies	<ul style="list-style-type: none"> • Check operation and correct if necessary. • Check for oil leakage and replace if necessary. 			√	√	√	
13	*	Front knuckle pivots	<ul style="list-style-type: none"> • Lubricate with lithium-soap-based grease. 			√	√	√	
14	*	Steering shaft	<ul style="list-style-type: none"> • Lubricate with lithium-soap-based grease. 			√	√	√	

NO.	ITEM	CHECK OR MAINTENANCE JOB	Whichever comes first ⇒	INITIAL			EVERY		
				month	1	3	6	6	12
				km (mi)	240 (150)	1300 (800)	2500 (1600)	2500 (1600)	5000 (3200)
hours	20	80	160	160	320				
15	*	Steering system	<ul style="list-style-type: none"> • Check operation and repair or replace if damaged. • Check toe-in and adjust if necessary. 	√	√	√	√	√	
16		Engine oil	<ul style="list-style-type: none"> • Change. • Check ATV for oil leakage, and correct if necessary. 	√		√	√	√	
17		Engine oil strainer	<ul style="list-style-type: none"> • Clean. 	√		√		√	
18		Transmission oil	<ul style="list-style-type: none"> • Change. • Check ATV for oil leakage, and correct if necessary. 	√				√	
19	*	Moving parts and cables	<ul style="list-style-type: none"> • Lubricate. 		√	√	√	√	
20	*	Throttle lever	<ul style="list-style-type: none"> • Check operation. • Check throttle lever free play, and adjust if necessary. • Lubricate cable and lever housing. 	√	√	√	√	√	
21	*	Brake switch	<ul style="list-style-type: none"> • Check operation and correct if necessary. 	√	√	√	√	√	
22	*	Switches	<ul style="list-style-type: none"> • Check operation and correct if necessary. 	√	√	√	√	√	

TIP _____
Some maintenance items need more frequent service if you are riding in unusually wet, dusty, sandy or muddy areas, or at full-throttle.

EBU23081

Removing and installing the panel

The panel shown needs to be removed to perform some of the maintenance jobs described in this chapter. Refer to this section each time the panel needs to be removed and installed.

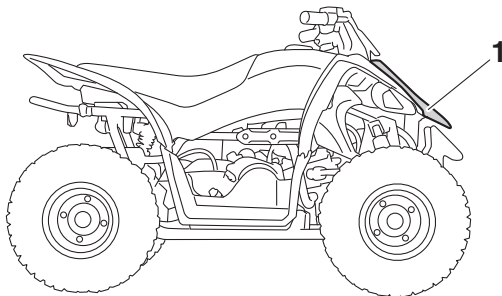

1. Panel A

EBU23102

Panel A

To remove the panel

Remove the bolts, and then take the panel off.

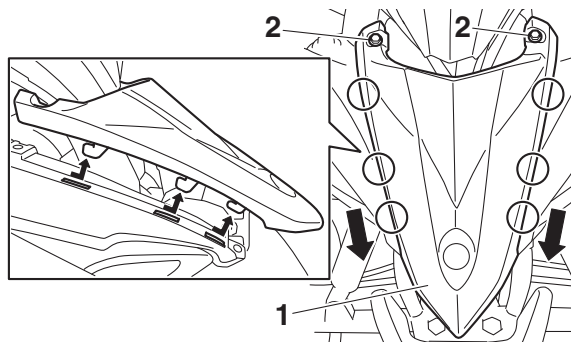

1. Panel A

2. Bolt

To install the panel

Place the panel in the original position and install the bolts.

EBU23214

Checking the spark plug

The spark plug is an important engine component, which is easy to check. Since heat and deposits will cause any spark plug to slowly erode, the spark plug should be removed and checked in accordance with the periodic maintenance and lubrication chart. In addition, the condition of the spark plug can reveal the condition of the engine.

To remove the spark plug

1. Remove the spark plug cap.

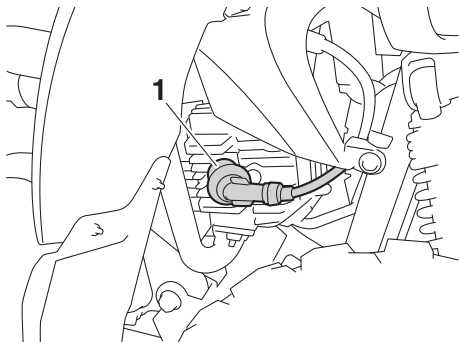

1. Spark plug cap

2. Remove the spark plug as shown, with the spark plug wrench included in the owner's tool kit.

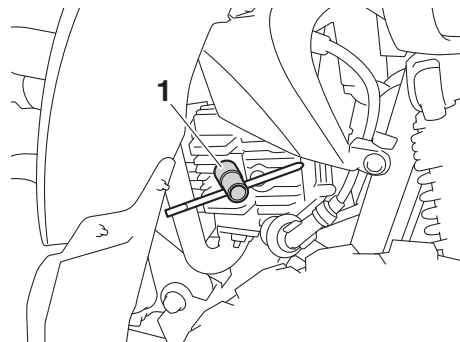

1. Spark plug wrench

To check the spark plug

1. Check that the porcelain insulator around the center electrode of the spark plug is a medium-to-light tan (the ideal color when the ATV is ridden normally).

TIP

If the spark plug shows a distinctly different color, the engine could be operating improperly. Do not attempt to diagnose such problems yourself. Instead, have a Yamaha dealer check the ATV.

2. Check the spark plug for electrode erosion and excessive carbon or other deposits, and replace it if necessary.

Specified spark plug:
NGK/CR6HSA

3. Measure the spark plug gap with a wire thickness gauge and, if necessary, adjust the gap to specification.

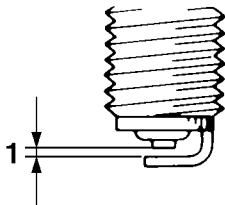

1. Spark plug gap

Spark plug gap:
0.6–0.7 mm (0.024–0.028 in)

To install the spark plug

1. Clean the surface of the spark plug gasket and its mating surface, and then wipe off any grime from the spark plug threads.
2. Install the spark plug with the spark plug wrench, and then tighten it to the specified torque.

Tightening torque:
Spark plug:
12 N·m (1.2 kgf·m, 8.7 lb·ft)

TIP

If a torque wrench is not available when installing the spark plug, a good estimate of the correct torque is 1/4–1/2 turn past finger tight. However, the spark plug should be tightened to the specified torque as soon as possible.

3. Install the spark plug cap.

EBU36791

Engine oil

The engine oil level should be checked before each ride. In addition, the oil must be changed at the intervals specified in the periodic maintenance and lubrication chart.

To check the engine oil level

1. Place the ATV on a level surface.
2. Check the engine oil level on a cold engine.

TIP

If the engine was started before checking the oil level, be sure to warm up the engine sufficiently, and then wait at least ten minutes until the oil settles for an accurate reading.

3. Remove the engine oil filler cap, and then wipe the engine oil dipstick off with a clean rag.

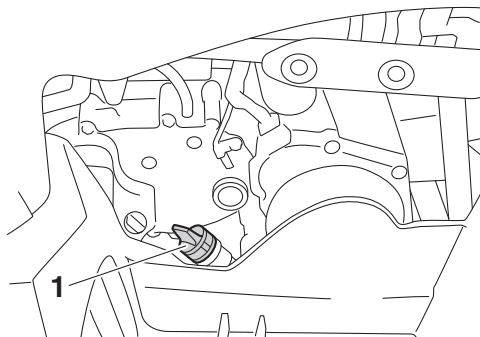

1. Engine oil filler cap

4. Insert the dipstick into the filler hole, screw it in, and then remove it again to check the oil level.

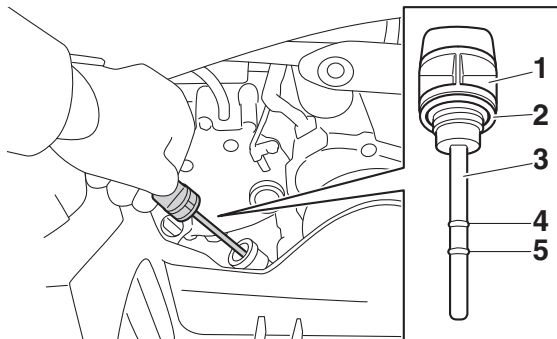

1. Engine oil filler cap
2. O-ring
3. Engine oil dipstick
4. Maximum level mark
5. Minimum level mark

TIP

The engine oil should be between the minimum and maximum level marks.

5. If the engine oil is at or below the minimum level mark, add sufficient oil of the recommended type to raise it to the correct level.

NOTICE: Be sure the engine oil is at the correct level, otherwise engine damage may result. [ECB00852]

6. Check the O-ring for damage, and replace it if necessary.
7. Insert the dipstick into the oil filler hole, and then tighten the engine oil filler cap.

To change the engine oil

1. Place the ATV on a level surface.
2. Start the engine, warm it up for several minutes, and then turn it off.
3. Place an oil pan under the engine to collect the used oil.
4. Remove the engine oil filler cap, and then remove the engine oil drain bolt to drain the oil from the crankcase. **NOTICE: When removing the engine oil drain bolt, the compression spring, oil strainer and O-ring will fall out. Take care not to lose these parts.**

[ECB00312]

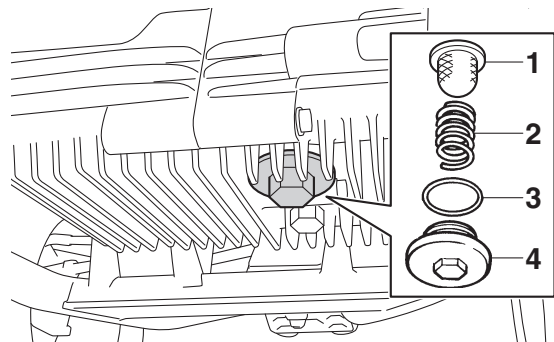

1. Oil strainer
2. Compression spring
3. O-ring
4. Engine oil drain bolt

5. Clean the oil strainer with solvent.
6. Apply a thin coat of clean engine oil to a new O-ring.
7. Install the oil strainer, the compression spring, the new O-ring and the engine oil drain bolt. Tighten the engine oil drain bolt to the specified torque. **NOTICE: Before installing the engine oil drain bolt, be sure to install the O-ring, compression spring and oil strainer.** [ECB00322]

Tightening torque:

Engine oil drain bolt:

25 N·m (2.5 kgf·m, 18 lb·ft)

8. Refill with the specified amount of the recommended engine oil.

Recommended oil:

See page 10-1.

Oil quantity:

0.90 L (0.95 US qt, 0.79 Imp.qt)

TIP

Be sure to wipe off spilled oil on any parts after the engine and exhaust system have cooled down.

8

ECB00331

NOTICE

- Do not use oils with a diesel specification of “CD” or oils of a higher quality than specified. In addition, do not use oils labeled “ENERGY CONSERVING II” or higher.
- Make sure that no foreign material enters the crankcase.

9. Check the engine oil filler cap O-ring for damage, and replace it if necessary.
10. Install and tighten the engine oil filler cap.
11. Start the engine, and then let it idle for several minutes while checking it for oil leakage. If oil is leaking, immediately turn the engine off and check for the cause.
12. Turn the engine off, wait at least ten minutes, and then check the oil level and correct it if necessary.

EBU34472

Transmission oil

The transmission case must be checked for oil leakage before each ride. If any leakage is found, have a Yamaha dealer check and repair the ATV. In addition, the transmission oil must be changed at the intervals specified in the periodic maintenance and lubrication chart.

To change the transmission oil

1. Place the ATV on a level surface.
2. Place an oil pan under the transmission case to collect the used oil.
3. Remove the transmission oil filler cap and its O-ring from the transmission case.

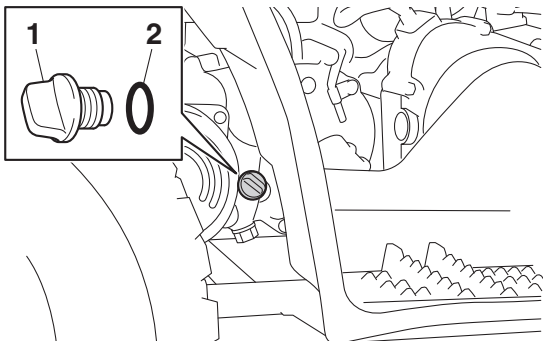

1. Transmission oil filler cap
2. O-ring

4. Remove the transmission oil drain bolt and its gasket to drain the oil from the transmission case.

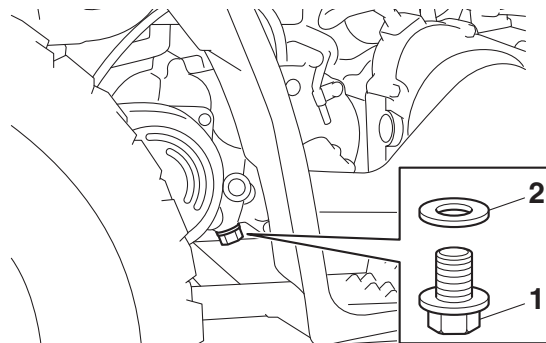

1. Transmission oil drain bolt
2. Gasket

5. Install the transmission oil drain bolt and its new gasket, and then tighten the bolt to the specified torque.

Tightening torque:
Transmission oil drain bolt:
30 N·m (3.0 kgf·m, 22 lb·ft)

6. Refill with the specified amount of the recommended oil. **NOTICE: Make sure that no foreign material enters the transmission case.** [ECB03380]

Recommended oil:

See page 10-1.

Oil quantity:

0.35 L (0.37 US qt, 0.31 Imp.qt)

7. Check the oil filler cap O-ring for damage, and replace it if necessary.
8. Install and tighten the oil filler cap.
9. Check the transmission case for oil leakage. If oil is leaking, check for the cause.

EBU34110

Cleaning the air filter element

The air filter element should be serviced at the intervals specified in the periodic maintenance and lubrication chart. Clean or, if necessary, replace the air filter element more frequently if you are riding in unusually wet or dusty areas.

TIP

There is a check hose at the bottom of the air filter case. If dust or water collects in this hose, empty the hose and clean the air filter element and air filter case.

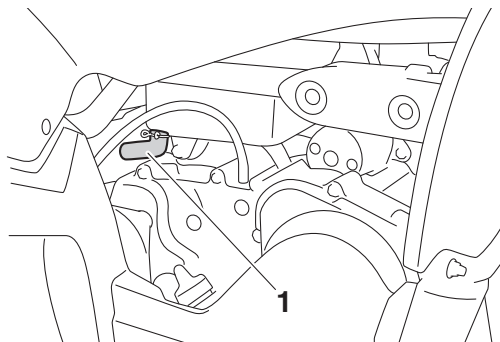

1. Air filter case check hose

1. Park the ATV on a level surface.
2. Remove the seat. (See page 4-12.)
3. Remove the air filter case cover by unhooking the air filter case cover holders.

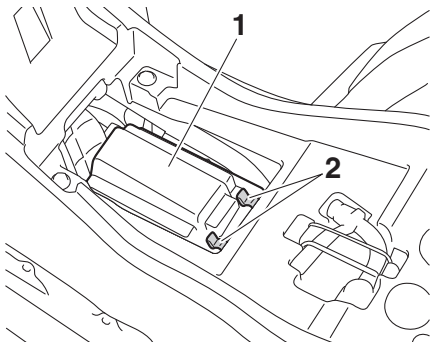

1. Air filter case cover
2. Air filter case cover holder

4. Remove the air filter element, and clean it with solvent. **WARNING! Always use parts cleaning solvent to clean the air filter element. Never use low-flash-point solvents or gasoline to clean the air filter element because the engine could catch fire or explode.** [EWB03540]

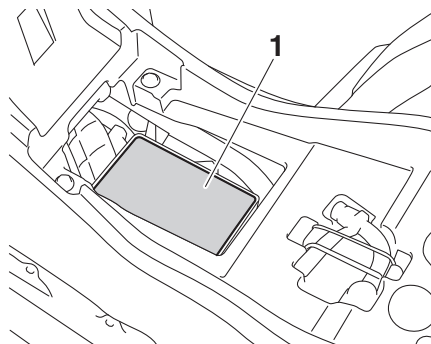

1. Air filter element

5. Squeeze the excess solvent out of the air filter element and let it dry. **NOTICE: Do not twist the air filter element when squeezing it.**

[ECB02310]

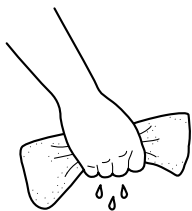

6. Check the air filter element and replace it if damaged.
7. Apply Yamaha foam air filter oil or other quality foam air filter oil to the element.

8

TIP

The air filter element should be wet but not dripping.

8. Insert the air filter element into the air filter case.
9. Install the air filter case cover by hooking the holders onto the air filter case. **NOTICE:** Make sure that the air filter element is properly seated in the air filter case. Never operate the engine with the air filter ele-

ment removed. This will allow unfiltered air to enter the engine, causing rapid engine wear and possible engine damage. Additionally, operation without the air filter element will affect carburetor jetting with subsequent poor performance and possible engine overheating. [ECB00462]

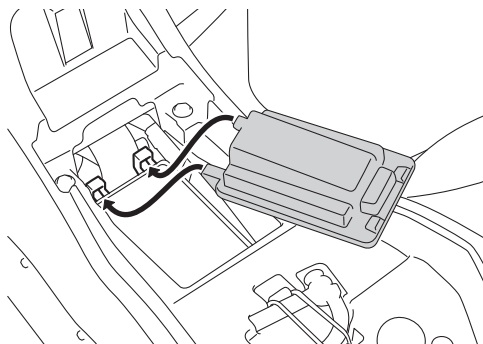

10. Install the seat.

TIP

The air filter element should be cleaned every 20–40 hours. It should be cleaned and lubricated more often if the ATV is operated in extremely

dusty areas. When servicing the air filter element, be sure to check the air inlet of the air filter case for obstructions.

EBU28904

Cleaning the spark arrester

Be sure the exhaust pipe and muffler are cool before cleaning the spark arrester.

1. Remove the tailpipe bolts.

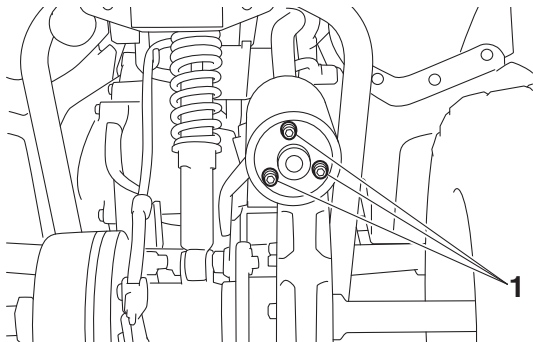

1. Tailpipe bolt

2. Remove the tailpipe by pulling it out of the muffler, and then remove the gasket.

3. Tap the tailpipe lightly, and then use a wire brush to remove any carbon deposits from the spark arrester portion of the tailpipe and inside of the tailpipe housing.

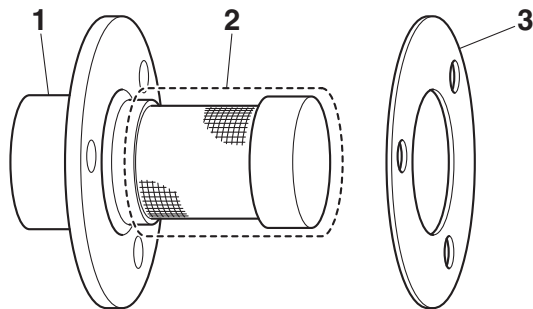

1. Tailpipe
2. Spark arrester
3. Gasket

4. Check the gasket for damage, and replace it if necessary.
5. Make sure the gasket is properly positioned, then insert the tailpipe into the muffler and align the bolt holes.
6. Install the bolts and tighten them to the specified torque.

Tightening torque:

Tailpipe bolt:

10 N·m (1.0 kgf·m, 7.2 lb·ft)

EWB02341



Do not start the engine when cleaning the spark arrester, otherwise it could cause injury to the eyes, burns, carbon monoxide poisoning, possibly leading to death, and start a fire. Always let the exhaust system cool prior to touching exhaust components.

EBU23941

Adjusting the carburetor

8

The carburetor should be checked and, if necessary, adjusted at the intervals specified in the periodic maintenance and lubrication chart. The carburetor is an important part of the engine and requires very sophisticated adjustment. Therefore, most carburetor adjustments should be left to a Yamaha dealer, who has the necessary professional knowledge and experience. The adjustment described in the following section, however, may be performed by the owner as part of routine maintenance.

ECB00481

NOTICE

The carburetor has been set and extensively tested at the Yamaha factory. Changing these settings without sufficient technical knowledge may result in poor performance or damage to the engine.

EBU24001

Adjusting the engine idling speed

The engine idling speed must be checked and, if necessary, adjusted as follows at the intervals specified in the periodic maintenance and lubrication chart.

TIP

A diagnostic tachometer is needed to make this adjustment.

1. Start the engine and warm it up.

TIP

The engine is warm when it quickly responds to the throttle.

2. Attach the tachometer to the spark plug lead.

3. Check the engine idling speed and, if necessary, adjust it to specification by turning the throttle stop screw at the carburetor. To increase the engine idling speed, turn the throttle stop screw in direction (a), and to decrease it, turn the screw in direction (b).

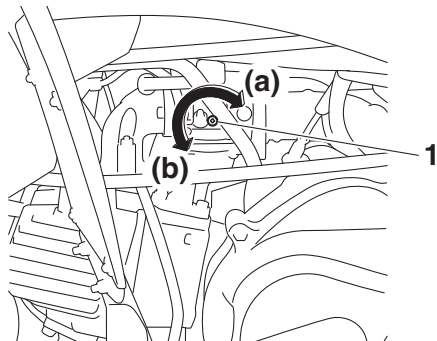

1. Throttle stop screw

Engine idling speed:
1600–1800 r/min

TIP

If the specified idling speed cannot be obtained as described above, have a Yamaha dealer make the adjustment.

EBU33950

Adjusting the throttle lever free play

The throttle lever free play should be checked and, if necessary, adjusted at the intervals specified in the periodic maintenance and lubrication chart.

The throttle lever free play should measure 2.0–3.2 mm (0.08–0.13 in) as shown. Periodically check the throttle lever free play and, if necessary, adjust it as follows.

TIP

The engine idling speed must be checked, and adjusted if necessary, before adjusting the throttle lever free play.

1. Slide the rubber covers apart.
2. Loosen the locknut.
3. To increase the throttle lever free play, turn the throttle lever free play adjusting nut in direction (a). To decrease the throttle lever free play, turn the adjusting nut in direction (b).

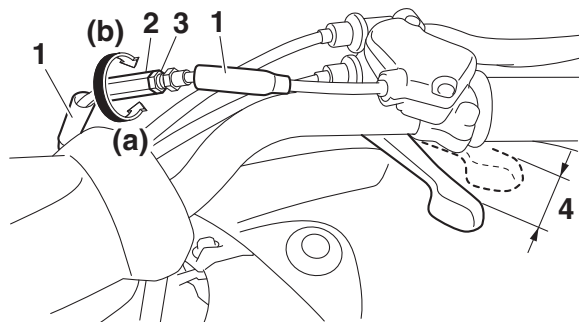

1. Rubber cover
 2. Throttle lever free play adjusting nut
 3. Locknut
 4. Throttle lever free play
- 8**
4. Tighten the locknut.
 5. Slide the rubber covers to their original positions.

EBU24061

Valve clearance

The valve clearance changes with use, resulting in improper air-fuel mixture and/or engine noise. To prevent this from occurring, the valve clearance must be adjusted by a Yamaha dealer at the intervals specified in the periodic maintenance and lubrication chart.

EBU29602

Brakes

Replacement of brake components requires professional knowledge. Brake service should be performed by a Yamaha dealer.

EWB02572

! WARNING

Operating with improperly serviced or adjusted brakes could lead to a loss in braking ability and an accident.

EBU34511

Checking the front and rear brake shoes

The front and rear brake shoes must be checked for wear at the intervals specified in the periodic maintenance and lubrication chart. Without disassembling the brake, this can be performed by checking the position of the brake lever free play adjusting bolts or nut.

Front brakes

To check front brake shoe wear, check the position of the adjusting bolts. If a bolt extends more than 12 mm (0.47 in) from its locknut, the brake shoes need to be replaced.

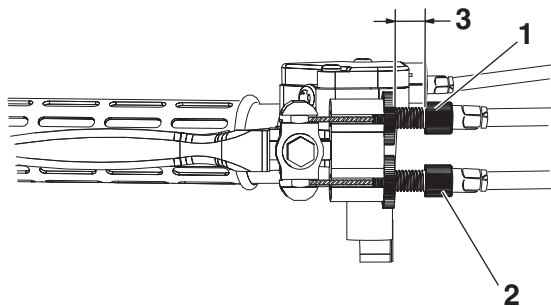

1. Upper adjusting bolt
2. Lower adjusting bolt
3. No more than 12 mm (0.47 in)

Rear brake

To check rear brake shoe wear, check the position of the adjusting nut. If the nut is more than 18 mm (0.71 in) from the end of the bolt, the brake shoes need to be replaced.

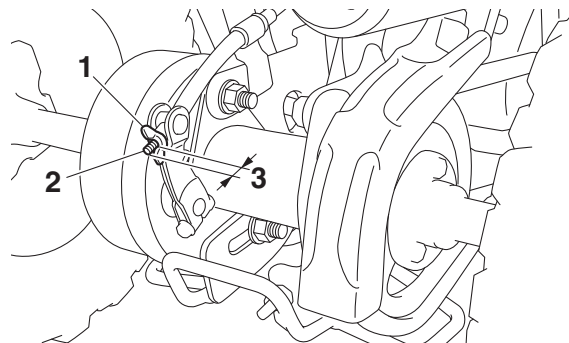

1. Rear brake lever free play adjusting nut
2. Bolt
3. No more than 18 mm (0.71 in)

EBU24332

Adjusting the front brake lever free play

The front brake lever free play must be checked and, if necessary, adjusted at the intervals specified in the periodic maintenance and lubrication chart.

The brake lever free play should measure 9.3–13.3 mm (0.37–0.52 in) as shown. If the free play is incorrect, adjust it as follows.

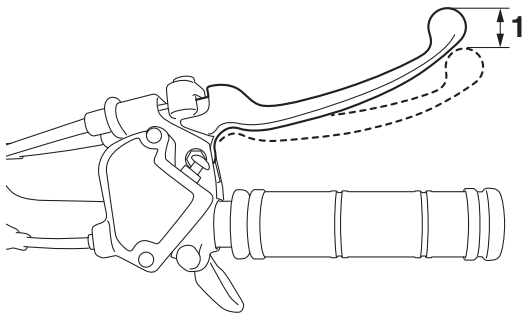

1. Front brake lever free play

1. Loosen the upper locknut and fully turn in the upper adjusting bolt.
2. Loosen the lower locknut.
3. Turn the lower adjusting bolt in direction (a) to increase the lever free play, and in direction (b) to decrease it.

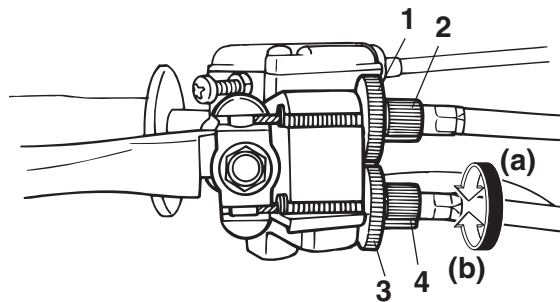

1. Upper locknut
2. Upper adjusting bolt
3. Lower locknut
4. Lower adjusting bolt
4. Tighten the lower locknut.
5. While applying the front brake, turn out the upper adjusting bolt until the upper and lower cable lengths are equal. The cable joint will become vertical.

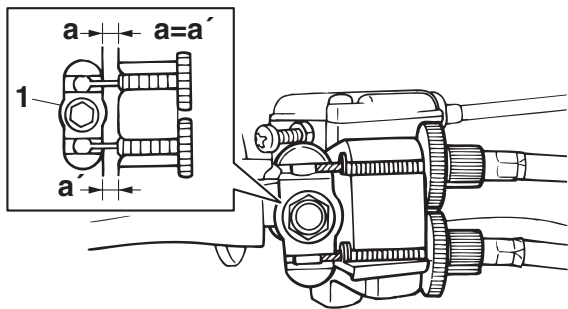

1. Cable joint

6. Tighten the upper locknut.

TIP

After adjusting the brake lever free play, check the front brake shoes for wear.

EBU33782

Adjusting the rear brake lever free play

The rear brake lever free play must be checked and, if necessary, adjusted at the intervals specified in the periodic maintenance and lubrication chart.

The brake lever free play should measure 7.6–12.9 mm (0.30–0.51 in) as shown. If the free play is incorrect, adjust it as follows.

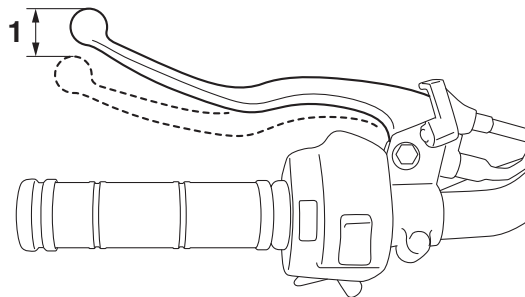

1. Rear brake lever free play

Turn the adjusting nut in direction (a) to increase the brake lever free play, and in direction (b) to decrease it.

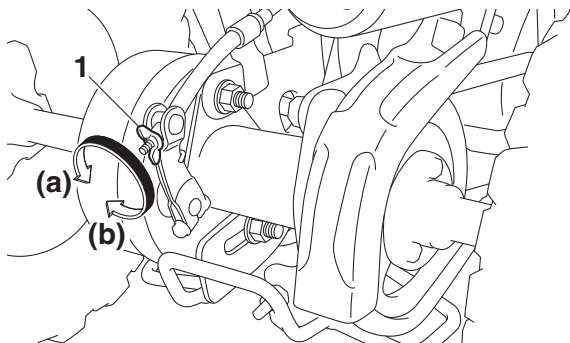

1. Rear brake lever free play adjusting nut

TIP
After adjusting the brake lever free play, check the rear brake shoes for wear.

8

EBU34013

Drive chain slack

The drive chain slack should be checked before each ride and adjusted if necessary.

To check the drive chain slack

1. Place the ATV on a level surface.

TIP
When checking and adjusting the drive chain slack, there should be no weight on the ATV and all tires must be touching the ground.

2. Move the ATV back and forth to locate the tightest portion of the drive chain, and then measure the drive chain slack as shown.

Drive chain slack:
6.0–12.0 mm (0.24–0.47 in)

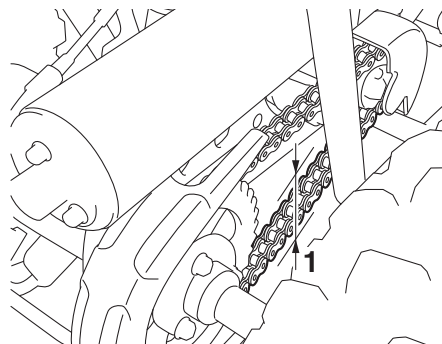

1. Drive chain slack

3. If the drive chain slack is incorrect, adjust it as follows.

To adjust the drive chain slack

1. Loosen the bolts and nuts.

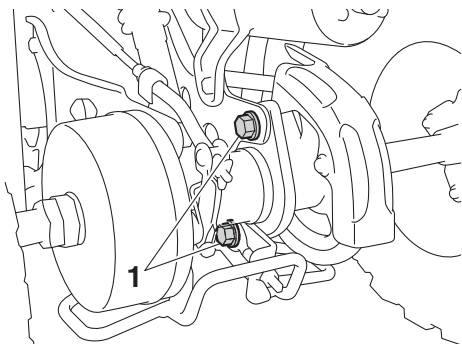

1. Bolt

2. Loosen the rear brake lever free play adjusting nut.

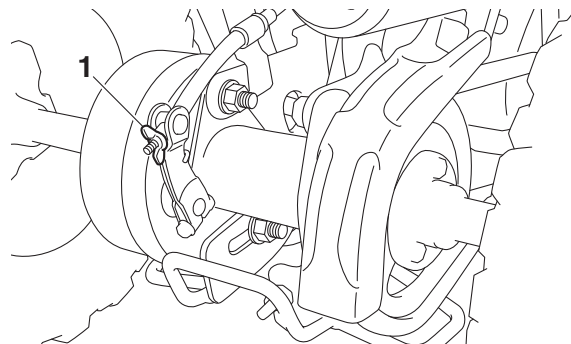

1. Rear brake lever free play adjusting nut

3. Loosen the locknut.

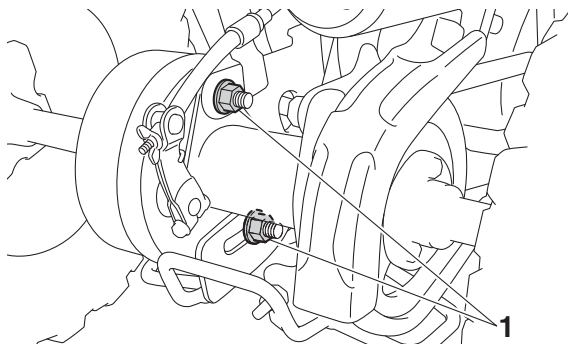

1. Nut

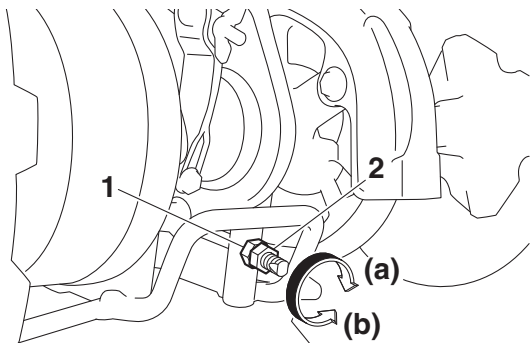

1. Drive chain slack adjusting nut
2. Locknut

4. To tighten the drive chain, turn the drive chain slack adjusting nut in direction (a). To loosen the drive chain, turn the adjusting nut in direction (b) and push the rear wheels forward.
NOTICE: Improper drive chain slack will overload the engine as well as other vital parts of the ATV and can lead to drive chain slippage or breakage. To prevent this from occurring, keep the drive chain slack within the specified limits. [ECB00543]
5. Tighten the locknut, and then the bolts and nuts to their specified torques.

Tightening torques:

Locknut:

22 N·m (2.2 kgf·m, 16 lb·ft)

Bolt:

45 N·m (4.5 kgf·m, 33 lb·ft)

Nut:

54 N·m (5.4 kgf·m, 39 lb·ft)

6. Adjust the rear brake lever free play. (See page 8-25.)

EBU36480

Cleaning and lubricating the drive chain

The drive chain must be cleaned and lubricated at the intervals specified in the periodic maintenance and lubrication chart, otherwise it will quickly wear out, especially when riding in dusty or wet areas. Service the drive chain as follows.

ECB00562

NOTICE

The drive chain must be lubricated after washing the ATV or riding in the rain or wet areas.

1. Remove all dirt and mud from the drive chain with a brush or cloth.

TIP

For a thorough cleaning, have a Yamaha dealer remove the drive chain and soak it in solvent.

2. Spray Yamaha chain lubricant or other suitable chain lubricant on the entire chain, making sure that all side plates and rollers have been sufficiently oiled.

EBU24905

Checking and lubricating the cables

The operation and the condition of all control cables should be checked before each ride, and the cables and cable ends should be lubricated if necessary. If a cable is damaged or does not move smoothly, have a Yamaha dealer check or replace it.

Recommended lubricant:
Yamaha cable lubricant or other suitable cable lubricant

EWB02582



- **Inspect cables frequently and replace if damaged. Corrosion can result when the cable sheaths become damaged, and cables**

can also become frayed or kinked, which could restrict the operation of controls and lead to an accident or injury.

- **Always make sure all control cables work smoothly before you begin riding in cold weather. If the control cables are frozen or do not work smoothly, you could be unable to control the ATV, which could lead to an accident or collision.**

EBU28703

Checking and lubricating the front and rear brake levers

The operation of the front and rear brake levers should be checked before each ride, and the lever pivots should be lubricated if necessary.

Recommended lubricant:
Lithium-soap-based grease

Front brake lever

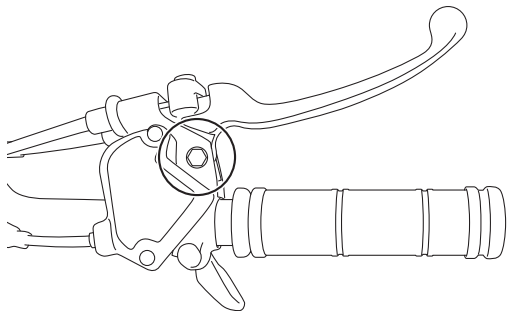

Rear brake lever

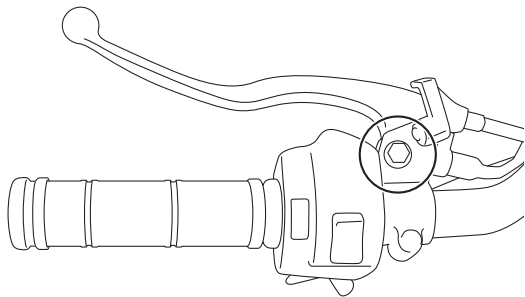

EBU24964

Checking the wheel hub bearings

The front and rear wheel hub bearings must be checked at the intervals specified in the periodic maintenance and lubrication chart. If there is play in a wheel hub or if a wheel does not turn smoothly, have a Yamaha dealer check the wheel hub bearings.

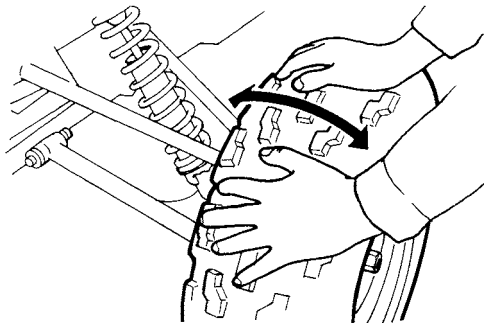

EBU36390

Lubricating the front arm pivots

The front arm pivots must be lubricated at the intervals specified in the periodic maintenance and lubrication chart.

TIP _____
For parts equipped with a grease nipple, use a grease gun.

Recommended lubricant:
Lithium-soap-based grease

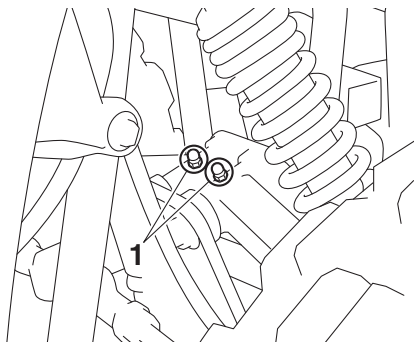

1. Grease nipple

EBU28824

Lubricating the front knuckle pivots

The front knuckle pivots must be lubricated at the intervals specified in the periodic maintenance and lubrication chart.

TIP _____
For parts equipped with a grease nipple, use a grease gun.

Recommended lubricant:
Lithium-soap-based grease

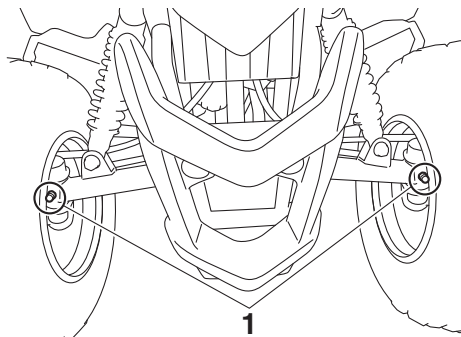

1. Grease nipple

EBU25094

Lubricating the steering shaft

The steering shaft must be lubricated by a Yamaha dealer at the intervals specified in the periodic maintenance and lubrication chart.

TIP _____
For parts equipped with a grease nipple, use a grease gun.

Recommended lubricant:
Lithium-soap-based grease

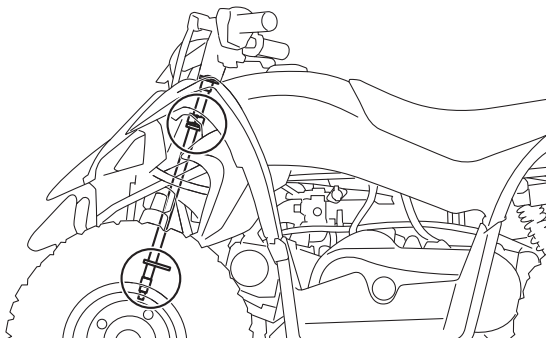

EBU36400

Battery

The battery is located under panel A. (See page 8-9.)

This model is equipped with a VRLA (Valve Regulated Lead Acid) battery. There is no need to check the electrolyte or to add distilled water. However, the battery lead connections need to be checked and, if necessary, tightened.

EWB02161

WARNING

Battery electrolyte is poisonous and dangerous, as it contains sulfuric acid, which can cause severe burns. Avoid contact with skin, eyes or clothing. Always shield your eyes when working near batteries.

Antidote:

EXTERNAL: Flush with water.

INTERNAL: Drink large quantities of water or milk. Follow with milk of magnesia, beaten egg or vegetable oil. Call a physician immediately.

EYES: Flush with water for 15 minutes and get prompt medical attention.

Batteries produce explosive gases. Keep sparks, flame, cigarettes or other sources of ignition away. Ventilate when charging or using in an enclosed space.

KEEP OUT OF REACH OF CHILDREN.

NOTICE

Never attempt to remove the battery cell seals, as this would permanently damage the battery.

To remove the battery

1. Remove panel A. (See page 8-9.)
2. Unhook the battery band.

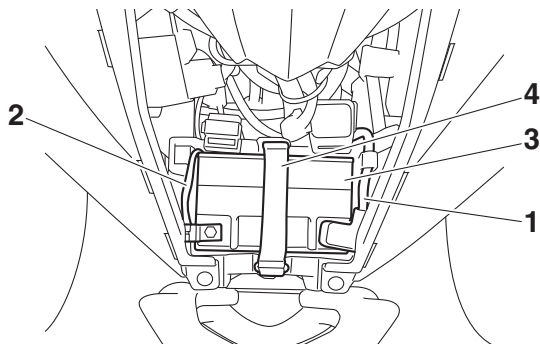

1. Positive battery lead (red)
2. Negative battery lead (black)
3. Battery
4. Battery band

3. Disconnect the negative battery lead first, then the positive battery lead by removing their bolt. **NOTICE: When removing the bat-**

tery, the main switch must be off, and the negative lead must be disconnected before the positive lead. [ECB01002]

4. Pull the battery out of its compartment.

To charge the battery

Have a Yamaha dealer charge the battery as soon as possible if it seems to have discharged. Keep in mind that the battery tends to discharge more quickly if the ATV is equipped with optional electrical accessories.

ECB00932

NOTICE

To charge a VRLA (Valve Regulated Lead Acid) battery, a special (constant-voltage) battery charger is required. Using a conventional battery charger will damage the battery.

8

To store the battery

- If the ATV will not be used for more than one month, remove the battery, fully charge it, and then place it in a cool, dry place.
- If the battery will be stored for more than two months, check it at least once a month and fully charge it if necessary.

NOTICE

Always keep the battery charged. Storing a discharged battery can cause permanent battery damage.

To install the battery**TIP**

Be sure the battery is fully charged.

1. Place the battery in its compartment.
2. Connect the positive battery lead first, then connect the negative battery lead by installing their bolt. **NOTICE: When installing the battery, the main switch must be off, and the positive lead must be connected before the negative lead.** [ECB01111]

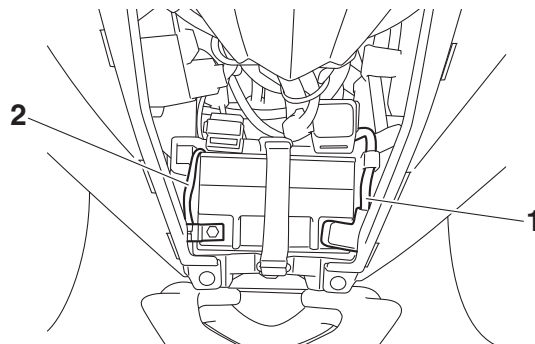

1. Positive battery lead (red)
2. Negative battery lead (black)
3. Hook the battery band.
4. Install the panel.

Replacing the fuse

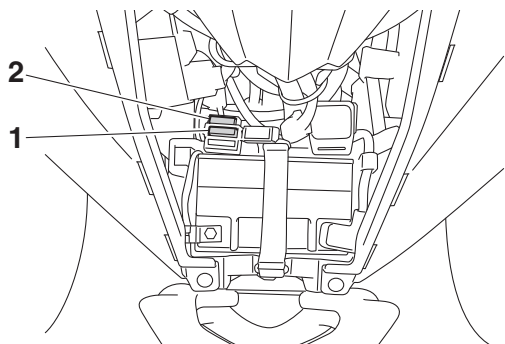

1. Fuse
2. Spare fuse

The fuse holder is located under panel A. (See page 8-9.)

If the fuse is blown, replace it as follows.

1. Turn the key to “OFF” and turn off all electrical circuits.

ECB00641

NOTICE

To prevent accidental short-circuiting, turn off the main switch when checking or replacing a fuse.

2. Remove the blown fuse, and then install a new fuse of the specified amperage. **WARNING! Always use a fuse of the specified rating, and never use a substitute object in place of the proper fuse. An improper fuse or a substitute object can cause damage to the electrical system, which could lead to a fire.** [EWB02173]

Specified fuse:
7.5 A

3. Turn the key to “ON” and turn on the electrical circuits to check if the devices operate.
4. If the fuse immediately blows again, have a Yamaha dealer check the electrical system.

EBU34030

Removing a wheel

1. Place the ATV on a level surface.
2. Loosen the wheel bolts.

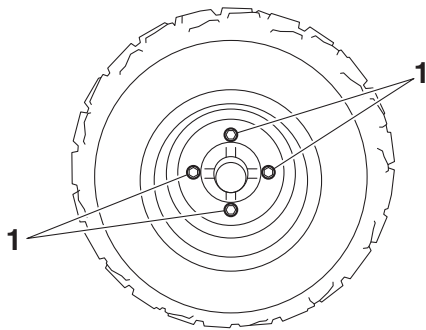

1. Wheel bolt

3. Elevate the ATV and place a suitable stand under the frame.
4. Remove the bolts from the wheel.
5. Remove the wheel.

8

EBU34041

Installing a wheel

1. Install the wheel and the bolts.

TIP

When installing the wheel, make sure its arrow mark \Rightarrow points toward the rotating direction of the wheel.

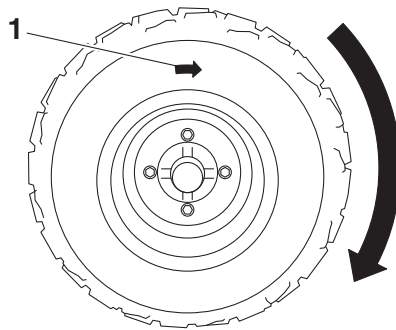

1. Arrow mark

2. Lower the ATV to the ground.
3. Tighten the wheel bolts to the specified torques.

Tightening torques:

Front wheel bolt:

45 N·m (4.5 kgf·m, 33 lb·ft)

Rear wheel bolt:

45 N·m (4.5 kgf·m, 33 lb·ft)

Troubleshooting

Although Yamaha ATVs receive a thorough inspection before shipment from the factory, trouble may occur during operation. Any problem in the fuel, compression, or ignition systems, for example, can cause poor starting and loss of power.

The following troubleshooting chart represents a quick and easy procedure for checking these vital systems yourself. However, should your ATV require any repair, take it to a Yamaha dealer, whose skilled technicians have the necessary tools, experience, and know-how to service the ATV properly.

Use only genuine Yamaha replacement parts. Imitation parts may look like Yamaha parts, but they are often inferior, have a shorter service life and can lead to expensive repair bills.

EWB02281



Do not smoke when checking the fuel system. Fuel can ignite or explode, causing severe injury or property damage. Make sure there are no open flames or sparks in the area, including pilot lights from water heaters or furnaces.

Troubleshooting chart

1. Fuel

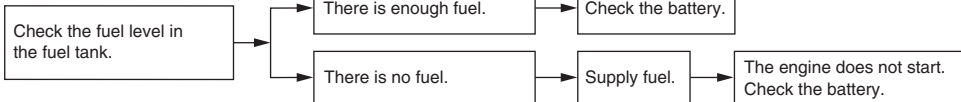

2. Battery

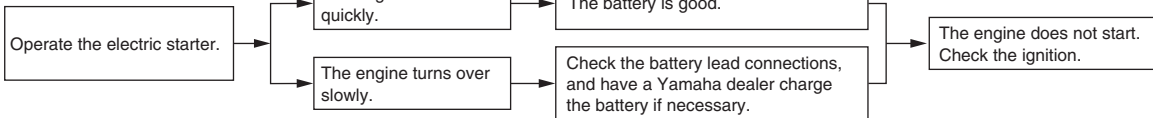

3. Ignition

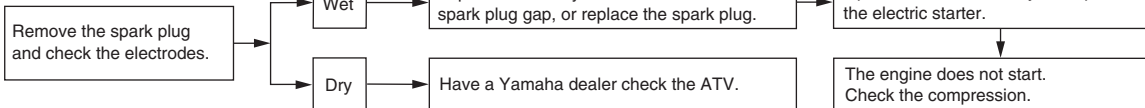

4. Compression

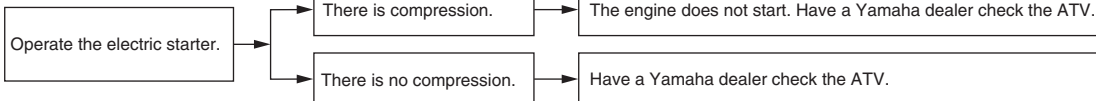

CLEANING AND STORAGE

EBU25903

Cleaning

Frequent, thorough cleaning of your ATV will not only enhance its appearance but will improve its general performance and extend the useful life of many components.

1. Before cleaning the ATV:
 - a. Block off the end of the exhaust pipe to prevent water entry. A plastic bag and strong rubber band may be used.
 - b. Make sure the spark plug and all filler caps are properly installed.
 2. If the engine case is excessively greasy, apply degreaser with a paint brush. Do not apply degreaser to the chain, sprockets or wheel axles.
 3. Rinse the dirt and degreaser off with a garden hose. Use only enough pressure to do the job. **WARNING! Wet brakes may have reduced stopping ability, increasing the chance of an accident. Test the brakes after washing. Apply the brakes several times at slow speeds to let friction dry out the linings.** [EWB02312] **NOTICE: Excessive wa-**
- ter pressure may cause water seepage and deterioration of wheel bearings, brakes, transmission seals and electrical devices. Many expensive repair bills have resulted from improper high-pressure detergent applications such as those available in coin-operated car washers.** [ECB00712]
4. Once most of the dirt has been hosed off, wash all surfaces with warm water and mild, detergent-type soap. An old toothbrush or bottle brush is handy for hard-to-reach places.
 5. Rinse the ATV off immediately with clean water and dry all surfaces with a chamois, clean towel or soft absorbing cloth.
 6. Dry the chain and lubricate it to prevent it from rusting.
 7. Clean the seat with a vinyl upholstery cleaner to keep the cover pliable and glossy.
 8. Automotive type wax may be applied to all painted and chrome plated surfaces. Avoid combination cleaner-waxes. Many contain

abrasives which may mar the paint or protective finish. When finished cleaning, start the engine and let it idle for several minutes.

EBU30361

Storage

Short-term

Always store your ATV in a cool, dry place and, if necessary, protect it against dust with a porous cover. **NOTICE: Storing the ATV in a poorly ventilated room or covering it with a tarp while it is still wet, will allow water and humidity to seep in and cause rust. To prevent corrosion, avoid damp cellars, stables (because of the presence of ammonia) and areas where strong chemicals are stored.** [ECB00722]

9

Long-term

Before storing your ATV for several months:

1. Follow all the instructions in the “Cleaning” section of this chapter.
2. Turn the fuel cock lever to “OFF”.
3. Drain the carburetor float chamber by loosening the drain bolt; this will prevent fuel deposits from building up. Pour the drained fuel into the fuel tank.

4. Fill up the fuel tank and add fuel stabilizer (if available) to prevent the fuel from deteriorating.

Specified amount:

7.5 ml of stabilizer to each liter of fuel (or 1 oz of stabilizer to each gallon of fuel)

5. Perform the following steps to protect the cylinder, piston rings, etc. from corrosion.
 - a. Remove the spark plug cap and spark plug.
 - b. Pour a teaspoonful of engine oil into the spark plug bore.
 - c. Install the spark plug cap onto the spark plug, and then place the spark plug on the cylinder head so that the electrodes are grounded. (This will limit sparking during the next step.)
 - d. Turn the engine over several times with the starter. (This will coat the cylinder wall with oil.)
 - e. Remove the spark plug cap from the spark plug, and then install the spark plug and the spark plug cap.
6. Lubricate all control cables and the pivoting points of all levers.

7. Check and, if necessary, correct the tire air pressure, and then block up the ATV so that all of its wheels are off the ground. Alternatively, turn the wheels a little every month in order to prevent the tires from becoming degraded in one spot.
8. Cover the muffler outlet with a plastic bag to prevent moisture from entering it.
9. Remove the battery and fully charge it. Store it in a cool, dry place and charge it once a month. Do not store the battery in an excessively cold or warm place [less than 0 °C (30 °F) or more than 30 °C (90 °F)]. For more information on storing the battery, see page 8-32.

TIP _____

Make any necessary repairs before storing the ATV.

SPECIFICATIONS

Dimensions:

- Overall length:
1250 mm (49.2 in)
- Overall width:
820 mm (32.3 in)
- Overall height:
770 mm (30.3 in)
- Seat height:
585 mm (23.0 in)
- Wheelbase:
830 mm (32.7 in)
- Ground clearance:
88 mm (3.5 in)
- Minimum turning radius:
2300 mm (91 in)

Weight:

- Curb weight:
100.0 kg (220 lb)

Noise and vibration level:

- Noise level (77/311/EEC):
74.0 dB(A) (EUR, FRA, GBR)
- Uncertainty of measurement:
2.0 dB(A) (EUR, FRA, GBR)
- Vibration on seat (EN1032, ISO5008):
Will not exceed 0.5 m/s² (EUR, FRA, GBR)
- Uncertainty of measurement:
0.1 m/s² (EUR, FRA, GBR)

- Vibration on handle (EN1032, ISO5008):
4.7 m/s² (EUR, FRA, GBR)
- Uncertainty of measurement:
0.4 m/s² (EUR, FRA, GBR)

Engine:

- Engine type:
Air cooled 4-stroke, SOHC
- Cylinder arrangement:
Single cylinder
- Displacement:
49 cm³
- Bore × stroke:
39.0 × 41.4 mm (1.54 × 1.63 in)
- Compression ratio:
8.5 : 1
- Starting system:
Electric starter and kickstarter
- Lubrication system:
Wet sump

Engine oil:

- Recommended brand:
YAMALUBE

Type:

SAE 5W-30, 10W-30, 10W-40, 15W-40, 20W-40 or 20W-50

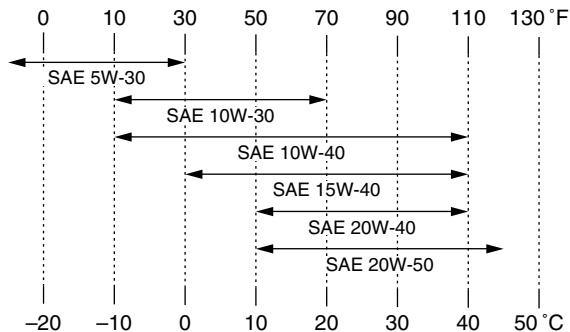

Recommended engine oil grade:

API service SG type or higher, JASO standard MA

Engine oil quantity:

Periodic oil change:

0.90 L (0.95 US qt, 0.79 Imp.qt)

Transmission oil:

Type:

SAE 80W-90

Quantity:

0.35 L (0.37 US qt, 0.31 Imp.qt)

Air filter:

Air filter element:

Wet element

Fuel:

Recommended fuel:

Regular unleaded gasoline only

Fuel tank capacity:

5.6 L (1.48 US gal, 1.23 Imp.gal)

Fuel reserve amount:

0.7 L (0.18 US gal, 0.15 Imp.gal)

Carburetor:

Type × quantity:

VM12

Spark plug (s):

Manufacturer/model:

NGK/CR6HSA

Spark plug gap:

0.6–0.7 mm (0.024–0.028 in)

Clutch:

Clutch type:

Dry, centrifugal automatic

Transmission:

Secondary reduction system:

Chain drive

Secondary reduction ratio:

38/13 (2.920)

Transmission type:

V-belt automatic

Operation:

Centrifugal automatic type

Chassis:

Frame type:

Steel tube frame

Caster angle:

1.10 °

Trail:

10.4 mm (0.41 in)

Front tire:

Type:

Tubeless

Size:

AT16 x 6.5-7

Manufacturer/model:

DURO/DI2040

Rear tire:

Type:

Tubeless

Size:

AT16 x 7-7

Manufacturer/model:

DURO/DI2041

Loading:

Maximum loading limit:

41.0 kg (90 lb)

(Total weight of rider, cargo, accessories, and tongue)

Tire air pressure (measured on cold tires):

Recommended:

Front:

13.8 kPa (0.14 kgf/cm², 2.0 psi)

Rear:

13.8 kPa (0.14 kgf/cm², 2.0 psi)

Minimum:

Front:

12.4 kPa (0.124 kgf/cm², 1.8 psi)

Rear:

12.4 kPa (0.124 kgf/cm², 1.8 psi)

Front wheel:

Wheel type:

Panel wheel

Rim size:

7 x 5.2AT

Rear wheel:

Wheel type:

Panel wheel

Rim size:

7 x 5.2AT

Front brake:

Type:

Mechanical leading, trailing drum brake

Operation:

Right hand operation

Rear brake:

Type:

Mechanical leading, trailing drum brake

Operation:

Left hand operation

Front suspension:

Type:

Swing axle

Spring/shock absorber type:

Coil spring/oil damper

Wheel travel:

60 mm (2.4 in)

Rear suspension:

Type:

Swingarm

Spring/shock absorber type:

Coil spring/oil damper

Wheel travel:

51 mm (2.0 in)

Electrical system:

Ignition system:

CDI

Charging system:

AC magneto

Battery:

Model:

GTX5L-BS

Voltage, capacity:

12 V, 4.0 Ah

Fuse:

Fuse:

7.5 A

EBU30402

For Europe only

The figures quoted are emission levels and are not necessarily safe working levels. Whilst there is a correlation between the emission and exposure levels, this cannot be used reliably to determine whether or not further precautions are required. Factors that influence the actual level of exposure

of work-force include the characteristics of the work room, the other sources of noise, etc. i.e. the number of machines and other adjacent processes, and the length of time for which an operator is exposed to the noise. Also the permissible exposure level can vary from country. This information, however, will enable the user of the machine to make a better evaluation of the hazard and risk.

CONSUMER INFORMATION

EBU28202

Identification numbers

Record the vehicle identification number and model label information in the spaces provided below for assistance when ordering spare parts from a Yamaha dealer or for reference in case the ATV is stolen.

VEHICLE IDENTIFICATION NUMBER:

MODEL LABEL INFORMATION:

11 EBU26031 Vehicle identification number

The vehicle identification number is stamped into the frame.

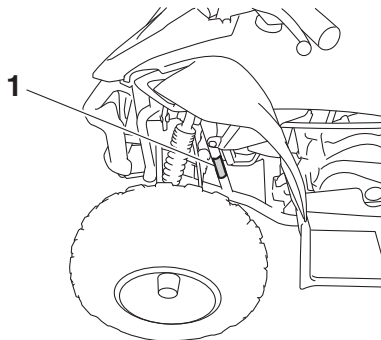

1. Vehicle identification number

TIP _____
The vehicle identification number is used to identify your ATV.

EBU26051

Model label

The model label is affixed at the location in the illustration. Record the information on this label in the space provided. This information will be needed when ordering spare parts from a Yamaha dealer.

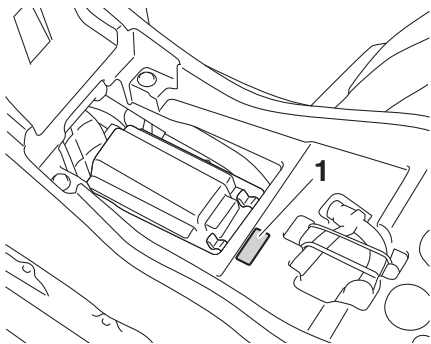

1. Model label

INDEX

A

- Accessories and loading6-5
- Air filter element, cleaning8-16

B

- Battery8-32
- Brake lever free play, adjusting the front8-23
- Brake lever free play (rear), adjusting8-25
- Brake lever, front4-5
- Brake lever, rear4-6
- Brake levers, checking and lubricating8-29
- Brakes8-22
- Brakes, front and rear5-3

C

- Cables, checking and lubricating8-29
- Carburetor, adjusting8-20
- Chassis fasteners5-6
- Cleaning9-1

D

- Drive chain5-3
- Drive chain, cleaning and lubricating8-28
- Drive chain slack8-26

E

- Engine break-in6-3
- Engine, cold start6-1
- Engine idling speed8-20
- Engine oil5-3, 8-11
- Engine, starting a warm6-3
- Engine stop switch4-1
- Engine stop switch with lanyard4-2

F

- Front and rear brake shoes, checking8-22
- Front arm pivots, lubricating8-30
- Front knuckle pivots, lubricating8-31
- Fuel4-8, 5-3
- Fuel cock4-10
- Fuel tank cap4-8
- Fuse, replacing8-35

H

- Handlebar switches4-1

I

- Identification numbers11-1
- Instruments and switches5-6

K

- Kickstarter4-7

L

- Label locations1-1

M

- Main switch4-1
- Maintenance and lubrication chart8-5
- Maintenance chart, emission control system8-3
- Model label11-1

O

- Owner's manual and tool kit8-2

P

- Panel, removing and installing8-9
- Parking6-3
- Parking brake4-6
- Parking on a slope6-4

Part locations	3-1
R	
Riding your ATV	7-1
S	
Safety information	2-1
Seat	4-12
Shock absorber assembly, adjusting the rear	4-13
Spark arrester, cleaning	8-19
Spark plug, checking	8-9
Specifications	10-1
Speed limiter	4-3
Starter (choke)	4-11
Start switch	4-2
Steering shaft, lubricating	8-31
Storage	9-2
T	
Throttle lever	4-3, 5-3
Throttle lever free play, adjusting	8-21
Tires	5-3
Transmission oil	5-3, 8-14
Troubleshooting	8-37
Troubleshooting chart	8-38
V	
Valve clearance	8-22
Vehicle identification number	11-1
W	
Wheel hub bearings, checking	8-30
Wheel, installing	8-36
Wheel, removing	8-35

⚠ WARNING

Improper ATV use can result in SEVERE INJURY or DEATH.



**ALWAYS USE
AN APPROVED
HELMET AND
PROTECTIVE GEAR**



**NEVER USE
ON PAVED
ROADS**



**NEVER CARRY
PASSENGERS**



**NEVER USE
WITH DRUGS
OR ALCOHOL**

NEVER operate:

- without proper training or instruction.
- at speeds too fast for your skills or the conditions.
- on public roads—a collision can occur with another vehicle.
- with a passenger—passengers affect balance and steering and increase risk of losing control.

ALWAYS:

- use proper riding techniques to avoid vehicle overturns on hills and rough terrain and in turns.
- avoid paved surfaces—pavement may seriously affect handling and control.

LOCATE AND READ OWNER'S MANUAL. FOLLOW ALL INSTRUCTIONS AND WARNINGS.

