



⚠ READ THIS MANUAL CAREFULLY!
It contains important safety information.

⚠ LIRE ATTENTIVEMENT CE MANUEL!
Il comprend d'importantes informations de sécurité.

⚠ ¡LEA ESTE MANUAL ATENTAMENTE!
Contiene indicaciones importantes acerca de la seguridad.

**OWNER'S MANUAL
MANUEL DU PROPRIÉTAIRE
MANUAL DEL PROPIETARIO**

GRIZZLY

**YFM70GDXG/YFM70GDHG
YFM70GPXG/YFM70GPHG
YFM70GPSG/YFM70GPLG**

2UD-F8199-60

Original instructions
Notice originale
Manual original



PRINTED IN USA
2015.05-0.9×1 CR
(E,F,S)



⚠ READ THIS MANUAL CAREFULLY!
It contains important safety information.

OWNER'S MANUAL

GRIZZLY

YFM70GDXG/YFM70GDHG

YFM70GPXG/YFM70GPHG

YFM70GPSG/YFM70GPLG

⚠ WARNING

This ATV should not be ridden by anyone under 16 years of age.

2UD-F8199-60-E0



Read this manual carefully before operating this vehicle. This manual should stay with this vehicle if it is sold.

EC Declaration of Conformity

conforming to Directive 2006/42/EC

We, **YAMAHA MOTOR CO., LTD.** 2500 Shingai, Iwata, Japan,
declare in sole responsibility, that the product

YFM700FWA (YFM70GDXG) (5Y4AMB9W0E0500101-)
(YFM70GDHG) (5Y4AMC2W0E0500101-)

(Make, model)

to which this declaration applies, conforms to the essential health and safety requirements of Directive 2006/42/EC

(If applicable)

and to the other relevant Directives of EEC

2004/108/EC

(Title and/or number and date of issue of the other Directives of EEC)

(If applicable)

To effect correct application of the essential health and safety requirements stated in the Directives of EEC, the following-standards and/or technical specifications were consulted:

EN15997, ANSI/SVIA 1-2010

(Title and/or number and date of issue of standards and/or specifications)

Manufacturer

YAMAHA MOTOR MANUFACTURING CORPORATION OF AMERICA
1000 GA Highway 34 East, Newnan, Georgia 30265-1320, U.S.A.

Authorized Representative

YAMAHA MOTOR EUROPE N.V.
Koolhovenlaan 101, 1119 NC Schiphol-Rijk, The Netherlands

Signature

Akihiro Tsuzuki

General Manager

Akihiro Tsuzuki

RV Engineering Division

Recreational Vehicle Business Unit

Business Development Operations

YAMAHA MOTOR CO., LTD.

Date of Issue

12 March, 2015

EC Declaration of Conformity

conforming to Directive 2006/42/EC

We, YAMAHA MOTOR CO., LTD. 2500 Shingai, Iwata, Japan,
declare in sole responsibility, that the product

YFM700FWAD	(YFM70GPXG)	(5Y4AMA8W0E0500101-)
	(YFM70GPHG)	(5Y4AMB7W0E0500101-)
	(YFM70GPSG)	(5Y4AMD1W0E0500101-)
	(YFM70GPLG)	(5Y4AMD3W0E0500101-)

(Make, model)

to which this declaration applies, conforms to the essential health and
safety requirements of Directive 2006/42/EC

(If applicable)

and to the other relevant Directives of EEC
2004/108/EC

(Title and/or number and date of issue of the other Directives of EEC)

(If applicable)

To effect correct application of the essential health and safety requirements
stated in the Directives of EEC, the following-standards and/or technical
specifications were consulted:

EN15997, ANSI/SVIA 1-2010

(Title and/or number and date of issue of standards and/or specifications)

Manufacturer

YAMAHA MOTOR MANUFACTURING CORPORATION OF AMERICA
1000 GA Highway 34 East, Newnan, Georgia 30265-1320, U.S.A.

Authorized Representative

YAMAHA MOTOR EUROPE N.V.

Koolhovenlaan 101, 1119 NC Schiphol-Rijk, The Netherlands

Signature

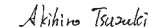

Akihiro Suzuki

General Manager

RV Engineering Division

Recreational Vehicle Business Unit

Business Development Operations

YAMAHA MOTOR CO., LTD.

Date of Issue

12 March, 2015

INTRODUCTION

Congratulations on your purchase of the Yamaha YFM70GDXG / YFM70GDHG / YFM70GPXG / YFM70GPHG / YFM70GPSG / YFM70GPLG. This ATV represents the result of many years of Yamaha experience in the production of fine sporting, touring, and pacesetting racing machines. With the purchase of this Yamaha, you can now appreciate the high degree of craftsmanship and reliability that have made Yamaha a leader in these fields.

This manual will provide you with a good basic understanding of the features and operation of this ATV. **This manual includes important safety information. It provides information about special techniques and skills necessary to ride the ATV.** It also includes basic maintenance and inspection procedures. If you have any questions regarding the operation or maintenance of your ATV, please consult a Yamaha dealer.



AN IMPORTANT SAFETY MESSAGE:

- Read this manual completely before operating your ATV. Make sure you understand all instructions.
- Pay close attention to the warning and notice labels on the ATV.
- This ATV should not be ridden by anyone under 16 years of age.

IMPORTANT MANUAL INFORMATION

FAILURE TO FOLLOW THE WARNINGS CONTAINED IN THIS MANUAL CAN RESULT IN SERIOUS INJURY OR DEATH.

Particularly important information is distinguished in this manual by the following notations:

	This is the safety alert symbol. It is used to alert you to potential personal injury hazards. Obey all safety messages that follow this symbol to avoid possible injury or death.
	A WARNING indicates a hazardous situation which, if not avoided, could result in death or serious injury.
	A NOTICE indicates special precautions that must be taken to avoid damage to the vehicle or other property.
TIP	A TIP provides key information to make procedures easier or clearer.

* Product and specifications are subject to change without notice.

EBU17351

IMPORTANT NOTICE

EBU17373

This ATV is designed and manufactured for use on unpaved surfaces only. It is unsafe to operate this ATV on any paved surface, paved street, paved road or motorway.

Please check your local riding laws and regulations before operating this ATV.

EBU17411

**YFM70GDXG / YFM70GDHG / YFM70GPXG
YFM70GPHG / YFM70GPSG / YFM70GPLG
OWNER'S MANUAL**

©2015 by Yamaha Motor Co., Ltd.

1st edition, April 2015

All rights reserved.

**Any reprinting or unauthorized use
without the written permission of
Yamaha Motor Co., Ltd.
is expressly prohibited.**

Printed in U.S.A.

TABLE OF CONTENTS

LOCATION OF THE WARNING AND SPECIFICATION LABELS	1-1	Storage compartments.....	4-18
SAFETY INFORMATION	2-1	Front carrier	4-22
DESCRIPTION.....	3-1	Rear carrier	4-22
Left view	3-1	Adjusting the front and rear shock absorber assemblies	4-22
Right view.....	3-1	Trailer hitch (YFM70GPSG / YFM70GPLG)	4-23
Controls and instruments.....	3-2	Auxiliary DC jack.....	4-24
INSTRUMENT AND CONTROL FUNCTIONS.....	4-1	PRE-OPERATION CHECKS	5-1
Main switch	4-1	Fuel	5-3
Indicator lights and warning lights	4-2	Engine oil	5-3
Multi-function display	4-5	Final gear oil	5-3
Handlebar switches	4-7	Differential gear oil.....	5-3
Throttle lever	4-13	Coolant	5-3
Speed limiter	4-13	Front and rear brakes	5-3
Front brake lever	4-14	Throttle lever.....	5-4
Brake pedal and rear brake lever.....	4-14	Tires	5-4
Drive select lever.....	4-15	Chassis fasteners	5-6
Fuel tank cap	4-15	Instruments, lights and switches	5-7
Fuel	4-16	OPERATION	6-1
Seat.....	4-17	Starting the engine	6-1

Operating the drive select lever and driving in reverse.....	6-2	Periodic maintenance chart for the emission control system.....	8-3
Engine break-in	6-4	General maintenance and lubrication chart.....	8-5
Parking	6-5	Removing and installing panels.....	8-10
Parking on a slope	6-5	Checking the spark plug.....	8-18
Accessories and loading.....	6-6	Engine oil and oil filter cartridge	8-21
RIDING YOUR ATV	7-1	Final gear oil	8-25
GETTING TO KNOW YOUR ATV	7-2	Differential gear oil.....	8-28
RIDE WITH CARE AND GOOD JUDGMENT	7-2	Coolant	8-30
BE CAREFUL WHERE YOU RIDE.....	7-10	Cleaning the air filter element	8-38
TURNING YOUR ATV.....	7-13	Cleaning the spark arrester	8-40
CLIMBING UPHILL	7-14	V-belt case drain plug.....	8-42
RIDING DOWNHILL	7-16	Adjusting the throttle lever free play	8-42
CROSSING A SLOPE.....	7-18	Valve clearance.....	8-43
CROSSING THROUGH SHALLOW WATER.....	7-19	Adjusting the drive select lever safety system cable	8-43
RIDING OVER ROUGH TERRAIN	7-21	Brakes.....	8-43
SLIDING AND SKIDDING.....	7-22	Checking the front and rear brake pads... ..	8-44
WHAT TO DO IF.....	7-23	Checking the brake fluid level	8-45
WHAT TO DO.....	7-23	Changing the brake fluid	8-46
PERIODIC MAINTENANCE AND ADJUSTMENT.....	8-1	Checking the front and rear brake lever free play	8-46
Owner's manual and tool kit	8-2	Adjusting the brake pedal free play	8-47
		Axle boots.....	8-49
		Checking and lubricating the cables	8-50

Checking and lubricating the front and rear brake levers 8-50

Checking and lubricating the brake pedal 8-51

Checking the wheel hub bearings..... 8-52

Checking the stabilizer bushes 8-52

Lubricating the rear knuckle pivots..... 8-52

Lubricating the steering shaft 8-53

Battery..... 8-54

Replacing a fuse 8-57

Replacing a headlight bulb 8-59

Adjusting a headlight beam 8-61

Tail/brake light..... 8-62

Removing a wheel..... 8-62

Installing a wheel..... 8-62

Troubleshooting 8-64

Troubleshooting charts 8-65

CLEANING AND STORAGE 9-1

 Cleaning 9-1

 Storage..... 9-2

SPECIFICATIONS 10-1

CONSUMER INFORMATION 11-1

 Identification numbers 11-1

LOCATION OF THE WARNING AND SPECIFICATION LABELS

Read and understand all of the labels on your ATV. These labels contain important information for safe and proper operation.

Never remove any labels from your ATV. If a label becomes difficult to read or comes off, request a replacement label from your Yamaha dealer.

For Europe

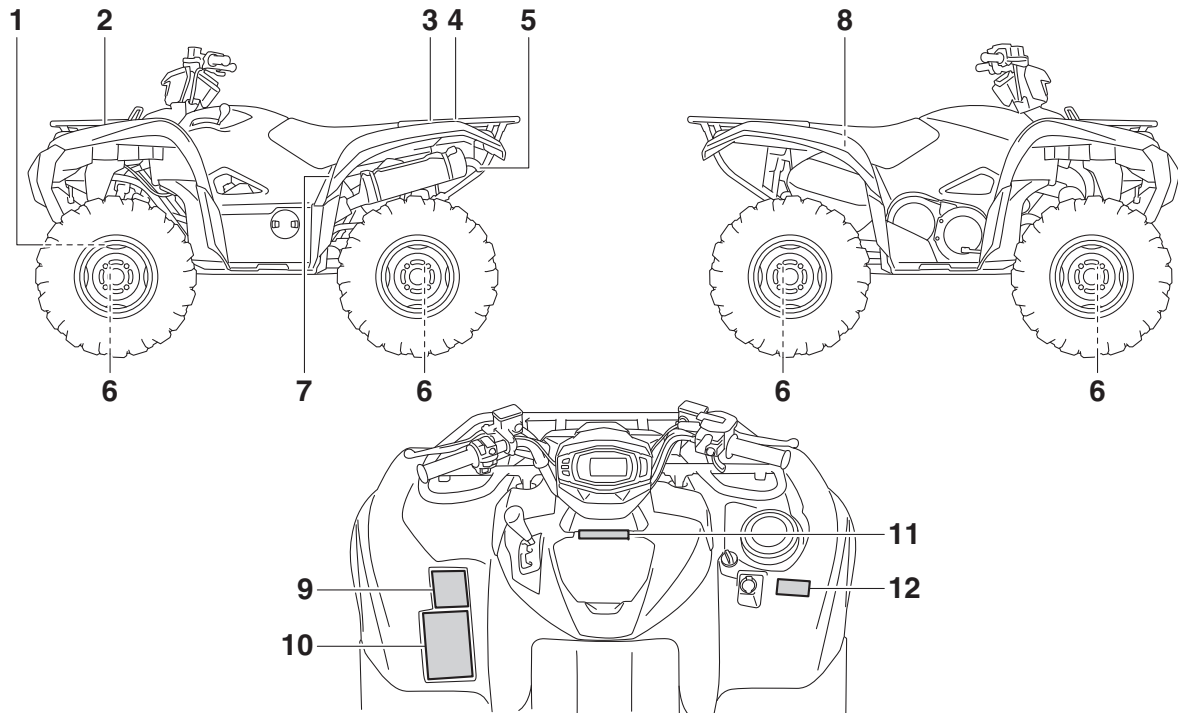

1**1 YFM70GDXG/YFM70GDHG****CE 2015**YAMAHA MOTOR CO., LTD.
2500 SHINGAI, IWATA, JAPAN

YFM700FWA

36.0 kW

308 kg

B30-F155A-00

1 YFM70GPXG/YFM70GPHG**CE 2015**YAMAHA MOTOR CO., LTD.
2500 SHINGAI, IWATA, JAPAN

YFM700FWAD

36.0 kW

314 kg

2UD-F155A-00

1 YFM70GPSG/YFM70GPLG**CE 2015**YAMAHA MOTOR CO., LTD.
2500 SHINGAI, IWATA, JAPAN

YFM700FWAD

36.0 kW

320 kg

B31-F155A-00

2< 50 kg
(110 lbs)

B16-F817R-00

3

YAMAHA

1P0-F816P-20

4< 90 kg
(198 lbs)

B16-F817R-10

5

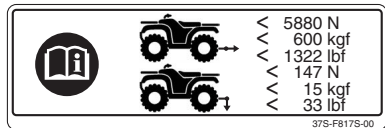

6



7

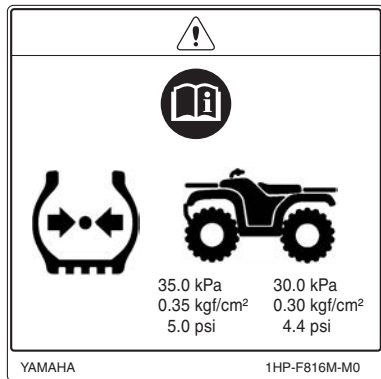

8



9

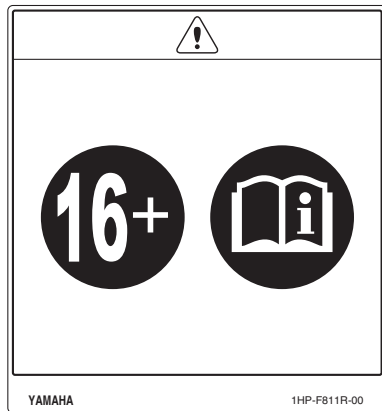

10



11

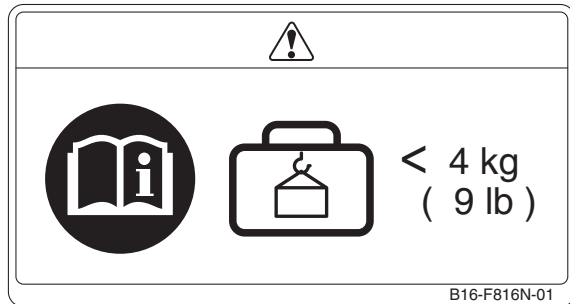



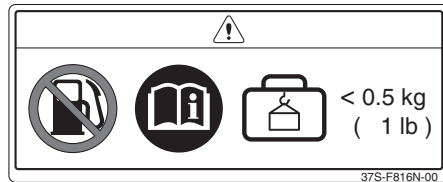













12



1

Familiarize yourself with the following pictograms and read the explanatory text, then make sure to check the pictograms that apply to your model.

	<p>Read the Owner's manual.</p>		<p>NEVER use on paved roads.</p>
	<p>ALWAYS use an approved helmet and protective gear.</p>		<p>NEVER carry passengers.</p>
	<p>For ATV Type 1 category Y12, use from 12 years old. Operation of this ATV by children under the age of 12 increases the risk of severe injury or death. Adult supervision required for children under age 16.</p>		<p>NEVER use with drugs or alcohol.</p>
	<p>Use from 16 years old. Operating this ATV if you are under the age of 16 increases your chance of severe injury or death.</p>		<p>NEVER store fuel or flammable liquids.</p>

	<p>This unit contains high-pressure nitrogen gas. Mishandling can cause an explosion. Do not incinerate, puncture or open.</p>		<p>Turning the ATV in 4WD-LOCK ("DIFF.LOCK") takes more effort. Operate at a slow speed and allow extra time and distance for maneuvers to avoid loss of control.</p>
	<p>Use unleaded gasoline only.</p>		<p>This pictogram shows the loading limits and/or maximum load capacity for this ATV. Follow all load limits and other loading guidelines in this manual. Load may include the driver, passenger, human protective gear, accessories, goods, luggage, and all other load related items. Make sure you do not exceed the load limits. Overloading can cause loss of control. Loss of control can result in severe injury or death.</p>
	<p>Measure the tire pressure when the tires are cold.</p>		<p>This pictogram shows trailer Hitch Tow weight limit. (Combined weight of the trailer and all cargo in the trailer.) Overloading can cause loss of control. Loss of control can result in severe injury or death.</p>
 <p>*** kPa *** kPa *** kgf/cm² *** kgf/cm² ** psi * psi</p>	<p>Adjust the tire pressure. Improper tire pressure can cause loss of control. Loss of control can result in severe injury or death.</p>		<p>This pictogram shows trailer Hitch Tongue weight limit. (Weight on the trailer tongue.) Overloading can cause loss of control. Loss of control can result in severe injury or death.</p>

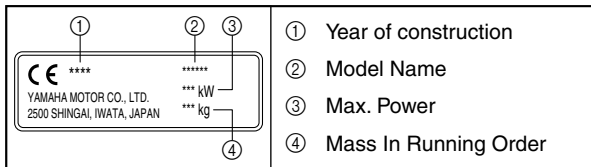

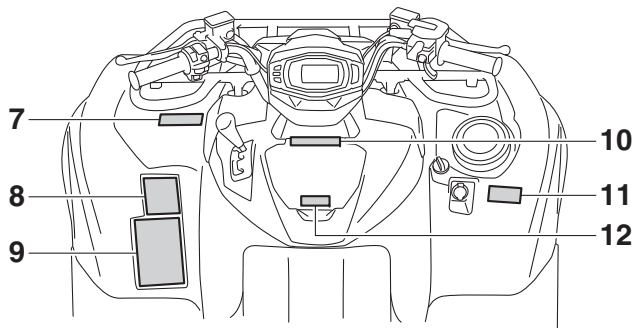
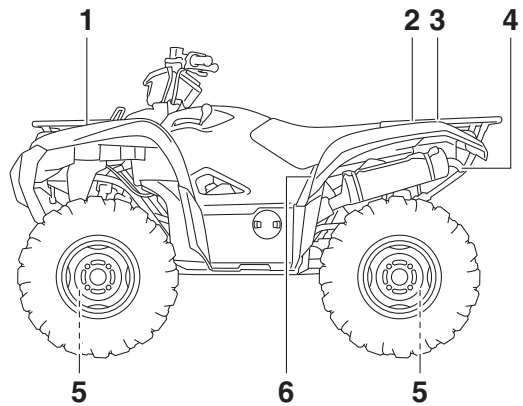

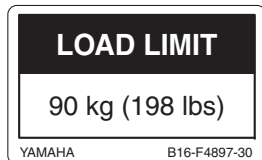
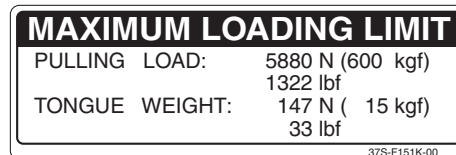
1**1****2****3****4**

5



6

⚠ WARNING

IMPROPER TIRE PRESSURE OR OVERLOADING CAN CAUSE LOSS OF CONTROL. LOSS OF CONTROL CAN RESULT IN SEVERE INJURY OR DEATH.

OPERATING TIRE PRESSURE : Set with tires cold

- Recommended : FRONT : 35 kPa, (5.0 psi)
REAR : 30 kPa, (4.4 psi)
- Minimum : FRONT : 32 kPa, (4.6 psi)
REAR : 27 kPa, (4.0 psi)
- Never set tire pressure below minimum. It could cause the tire to dislodge from the rim.

LOADING/TRAILER TOWING

- Cargo or a trailer can affect stability and handling. Read owner's manual before loading or towing.
- When riding with cargo or towing a trailer : Reduce speed and allow more room to stop. Avoid hills and rough terrain.
- Maximum Vehicle Load : 240 kg, (530 lbs)
Includes weight of operator, cargo and accessories (and if applicable, trailer tongue weight).

YAMAHA

B16-F816M-00

1

7

DRIVE SELECT LEVER

- Read owner's manual carefully before operating.
- ATV **MUST** be stopped before shifting select lever.
- Shifting into or from reverse or park is impossible without applying rear brake.

5ND-F151E-00

8

⚠ WARNING



Operating this ATV if you are under the age of **16** increases your chance of severe injury or death.

NEVER operate this ATV if you are under age **16**.

YAMAHA

1P0-F816L-00

9

⚠ WARNING

Improper ATV use can result in **SEVERE INJURY** or **DEATH**.



ALWAYS USE AN APPROVED HELMET AND PROTECTIVE GEAR



NEVER USE ON PUBLIC ROADS



NEVER CARRY PASSENGERS



NEVER USE WITH DRUGS OR ALCOHOL

NEVER operate :

- without proper training or instruction.
- at speeds too fast for your skills or the conditions.
- on public roads-a collision can occur with another vehicle.
- with a passenger-passengers affect balance and steering and increase risk of losing control.

ALWAYS :

- use proper riding techniques to avoid vehicle overturns on hills and rough terrain and in turns.
- avoid paved surfaces-pavement may seriously affect handling and control.

LOCATE AND READ OWNER'S MANUAL. FOLLOW ALL INSTRUCTIONS AND WARNINGS.

YAMAHA

4XE-F1568-10

10

⚠ WARNING

Storage should not exceed 4 kg (9 lbs)

B16-F151F-01

11

⚠ WARNING

- Fuel vapors can be a fire or explosion hazard. To avoid injury or death, never store fuel or flammable liquids in this storage compartment.
- Storage should not exceed 1 lb (0.5 kg).

37S-F151F-00

12

⚠ WARNING

Turning the ATV in 4WD-LOCK (“DIFF.LOCK”) takes more effort.

Operate at a slow speed and allow extra time and distance for maneuvers to avoid loss of control.

5ND-F1558-00

1



SAFETY INFORMATION

AN ATV IS NOT A TOY AND CAN BE HAZARDOUS TO OPERATE.

An ATV handles differently from other vehicles, including motorcycles and cars. A collision or roll-over can occur quickly, even during routine maneuvers such as turning and riding on hills or over obstacles, if you fail to take proper precautions.

SEVERE INJURY OR DEATH can result if you do not follow these instructions:

- Read this manual and all labels carefully and follow the operating procedures described.
- Never operate an ATV without proper training or instruction. Take a training course. Beginners should receive training from a certified instructor. Contact an authorized ATV dealer to find out about the training courses nearest you.
- Always follow the age recommendation:
 - A child under 16 years old should never operate an ATV with engine size greater than 90 cc.

- Never allow a child under age 16 to operate an ATV without adult supervision, and never allow continued use of an ATV by a child if he or she does not have the abilities to operate it safely.
- Never carry a passenger on an ATV.
- This vehicle is intended for off-road use only. Do not operate on any paved surfaces such as: sidewalks, driveways, parking lots, paved roads, public streets or other motorway.
- Watch carefully for other vehicles when operating on unpaved public streets or roads. Make sure you know your country's laws and regulations before you ride on unpaved public streets or roads.
- Never operate an ATV without wearing an approved motorcycle helmet that fits properly. You should also wear eye protection (goggles or face shield), gloves, boots, a long-sleeved shirt or a jacket, and long pants.
- Never consume alcohol or drugs before or while operating this ATV.

- Never operate at speeds too fast for your skills or the riding conditions. Always go at a speed that is proper for the terrain, visibility, operating conditions, and your experience.
- Never attempt wheelies, jumps, or other stunts.
- Always inspect your ATV each time you use it to make sure it is in safe operating condition. Always follow the inspection and maintenance procedures and schedules described in this manual.
- Always keep both hands on the handlebars and both feet on the footboards of the ATV during operation.
- Always go slowly and be extra careful when operating on unfamiliar terrain. Always be alert to changing terrain conditions when operating the ATV.
- Never operate on excessively rough, slippery or loose terrain until you have learned and practiced the skills necessary to control the ATV on such terrain. Always be especially cautious on these kinds of terrain.
- Always follow proper procedures for turning as described in this manual. Practice turning at low speeds before attempting to turn at faster speeds and never turn at excessive speeds.
- Never operate the ATV on hills too steep for the ATV or for your abilities. Practice on smaller hills before attempting larger hills.
- Always follow proper procedures for climbing hills as described in this manual. Check the terrain carefully before you start up any hill. Never climb hills with excessively slippery or loose surfaces. Shift your weight forward. Never open the throttle suddenly. Never go over the top of a hill at high speed.
- Always follow proper procedures for going down hills and for braking on hills as described in this manual. Check the terrain carefully before you start down any hill. Shift your weight backward. Never go down a hill at high speed. Avoid going down a hill at an angle that would cause the vehicle to lean sharply to one side. Go straight down the hill where possible.
- Always follow proper procedures for crossing the side of a hill as described in this manual. Avoid hills with excessively slippery or loose surfaces. Shift your weight to the uphill side of the ATV. Never attempt to turn the ATV around on any hill until you have mastered the turning

technique described in this manual on level ground. Avoid crossing the side of a steep hill if possible.

- Always use proper procedures if you stall or roll backwards when climbing a hill. To avoid stalling, use the proper gear range and maintain a steady speed when climbing a hill. If you stall or roll backwards, follow the special procedure for braking described in this manual. Dismount on the uphill side or to a side if pointed straight uphill. Turn the ATV around and remount, following the procedure described in this manual.
- Always check for obstacles before operating in a new area.
- Never attempt to operate over large obstacles, such as large rocks or fallen trees. Always follow proper procedures when operating over obstacles as described in this manual.
- Always be careful when skidding or sliding. Learn to safely control skidding or sliding by practicing at low speeds and on level, smooth terrain. On extremely slippery surfaces, such as ice, go slowly and be very cautious in order to reduce the chance of skidding or sliding out of control.
- Never operate an ATV in fast flowing water or in water deeper than that recommended in this manual. Remember that wet brakes may have reduced stopping ability. Test your brakes after leaving water. If necessary, apply them several times to let friction dry out the linings.
- Always be sure there are no obstacles or people behind you when you operate in reverse. When it is safe to proceed in reverse, go slowly.
- Always use the size and type of tires specified in this manual.
- Always maintain proper tire pressure as described in this manual.
- Never exceed the stated load capacity for an ATV. Cargo should be properly distributed and securely attached. Reduce speed and follow instructions in this manual for carrying cargo or pulling a trailer. Allow greater distance for braking.
- Do not operate your ATV during darkness unless it is equipped with a properly functioning headlight. Off-road riding is inherently dangerous and additionally, off-road trails do not have streetlights to guide you.

- Never maintain an ATV without proper knowledge. Contact an authorized ATV dealer to inform you on basic ATV maintenance. Certain maintenance can only be carried out by certified staff.

In the event of an accident

1. If serious injuries are incurred, you may be safer staying next to your vehicle; it may shield you from oncoming riders. Depending on your injuries and position in the trail; you must make a judgment call as to whether you should move to a position off the trail. If you have sustained head, neck, or back injuries, or cannot feel your limbs, you should not move. Keep your helmet on and remain motionless. Lie down next to your vehicle and wait for help.
2. If less serious injuries are incurred and you can walk, then move to a position off the trail. Check yourself for injuries and apply first aid as needed.
3. If your injuries are light, when safe to do so, move your vehicle off the trail to avoid collisions with oncoming riders. Check for injuries and apply first aid as necessary. If you can physically operate your vehicle, inspect your

vehicle. If the vehicle is in safe operating condition and you can safely operate it, restart it and ride gently back to camp or other known location where you can receive medical attention. If necessary, contact your riding party or local authorities to let them know where you are and what has happened.

In the event of a breakdown

1. If your vehicle will not restart or is not in safe operating condition, turn off the main switch and engine stop switch. If the breakdown occurs at twilight or night, leave the main switch on so that your lights may warn other riders of your stopped vehicle.
2. Get out of danger. Check for oncoming vehicles and when safe, push your vehicle to the side of the trail or even off the main trail to avoid any possible collisions with oncoming riders. If you cannot move your vehicle by yourself, when safe, walk to the nearest vantage point and signal an oncoming rider to help you push your vehicle to a safe place off the trail.
3. Inspect your vehicle for any immediate hazardous conditions. The most obvious hazardous conditions are leaking fuel and

ungrounded or broken wiring. Visually check for broken wiring and leaking fuel. Leaking fuel can be confirmed by the odor of gasoline.

4. Once immediate safety hazards are confirmed not to exist, you may remove your helmet to more closely inspect your vehicle. Check for external signs of wear, broken parts, fluid leaks, cracks in the frame, suspension damage, wheel damage, and so on. Fuel, oil, and coolant usually give off a noticeable odor.
5. If your vehicle will not restart or if it is unsafe to ride, then turn off all vehicle systems (engine stop switch, main switch, and fuel cock), and then signal or go for help.

Aftermarket Parts, Accessories, and Modifications

While you may find aftermarket products similar in design and quality to genuine Yamaha accessories, recognize that some aftermarket accessories or modifications are not suitable because of potential safety hazards to you or others. Installing aftermarket products or having other modifications performed to your vehicle that change any of the vehicle's design or operation characteristics can put you and others at greater risk of serious

injury or death. You are responsible for injuries related to changes in the vehicle. Keep the following guidelines in mind, as well as those provided under "Loading" when mounting accessories.

- Never install accessories that would impair the performance of your ATV. Carefully inspect the accessory before using it to make sure that it does not in any way reduce ground clearance, limit suspension travel, steering travel or control operation.
- Accessories fitted to the ATV can create instability due to improper weight distribution.
- Bulky or large accessories may seriously affect the stability of the ATV.
- Certain accessories can displace the operator from his or her normal riding position. This improper position limits the freedom of movement of the operator and may limit control ability, therefore, such accessories are not recommended.
- Use caution when adding electrical accessories. If electrical accessories exceed the capacity of the ATV's electrical system, an electric failure could result, which could cause a dangerous loss of lights or engine power.



Avoid Carbon Monoxide Poisoning

All engine exhaust contains carbon monoxide, a deadly gas. Breathing carbon monoxide can cause headaches, dizziness, drowsiness, nausea, confusion, and eventually death.

Carbon Monoxide is a colorless, odorless, tasteless gas which may be present even if you do not see or smell any engine exhaust. Deadly levels of carbon monoxide can collect rapidly and you can quickly be overcome and unable to save yourself. Also, deadly levels of carbon monoxide can linger for hours or days in enclosed or poorly ventilated areas. If you experience any symptoms of carbon monoxide poisoning, leave the area immediately, get fresh air, and **SEEK MEDICAL TREATMENT.**

- **Do not run engine indoors. Even if you try to ventilate engine exhaust with fans or open windows and doors, carbon monoxide can rapidly reach dangerous levels.**
- **Do not run engine in poorly ventilated or partially enclosed areas such as barns, garages, or carports.**

- **Do not run engine outdoors where engine exhaust can be drawn into a building through openings such as windows and doors.**

DESCRIPTION

Left view

3

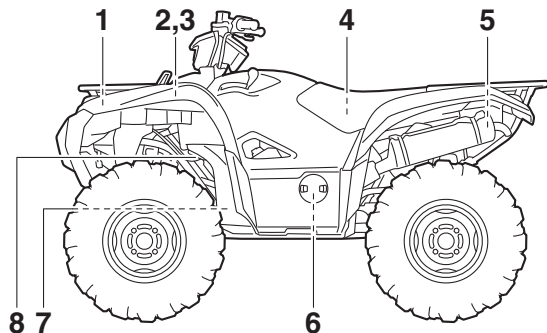

1. Radiator cap
2. Battery
3. Fuses
4. Air filter case
5. Spark arrester
6. Engine oil dipstick
7. Oil filter cartridge
8. Coolant reservoir

Right view

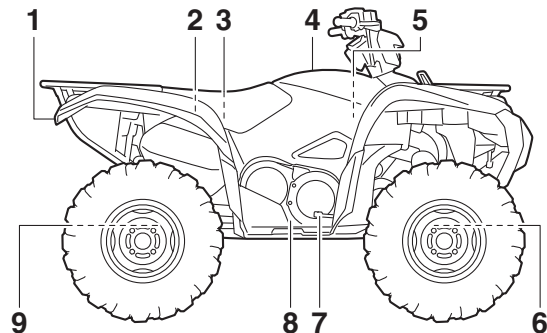

1. Rear storage compartment
2. Fuel tank cap
3. Owner's tool kit
4. Center storage compartment
5. Spark plug
6. Front shock absorber assembly spring preload adjusting ring
7. Brake pedal
8. V-belt case drain plug
9. Rear shock absorber assembly spring preload adjusting ring

Controls and instruments

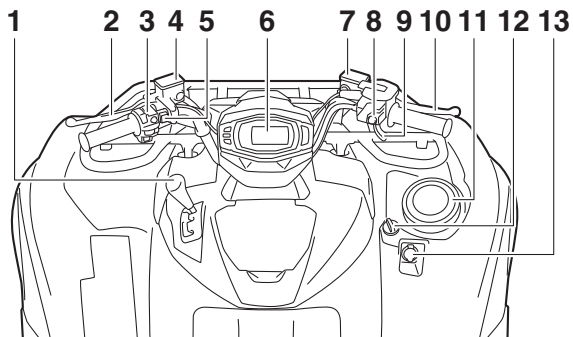

1. Drive select lever
2. Rear brake lever
3. Handlebar switches
4. Rear brake fluid reservoir
5. Horn switch
6. Multi-function display
7. Front brake fluid reservoir
8. On-Command four-wheel-drive/differential gear lock switch
9. Throttle lever
10. Front brake lever
11. Front storage compartment
12. Main switch
13. Auxiliary DC jack

TIP _____
 The ATV you have purchased may differ slightly from the figures shown in this manual.

INSTRUMENT AND CONTROL FUNCTIONS

EBU29912

Main switch

The positions of the main switch are as follows:

“**I**” (on)

All electrical systems are supplied with power. The headlights and taillight come on when the light switch is on, and the engine can be started. The key cannot be removed.

“**O**” (off)

All electrical systems are off. The key can be removed.

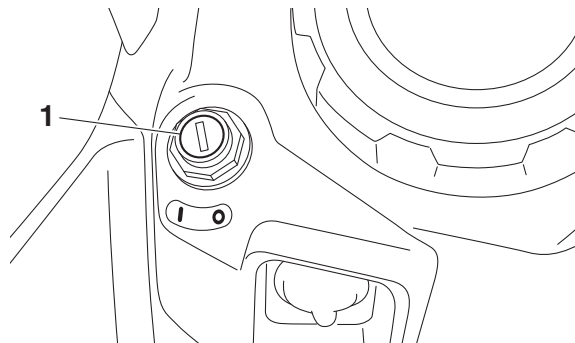

1. Main switch

Indicator lights and warning lights

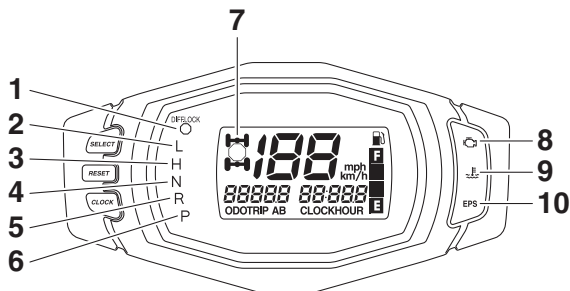

1. On-Command differential gear lock indicator light "DIFF. LOCK"
2. Low-range indicator light "L"
3. High-range indicator light "H"
4. Neutral indicator light "N"
5. Reverse indicator light "R"
6. Park indicator light "P"
7. On-Command four-wheel-drive/differential gear lock indicator "4x4"/"4x4"
8. Engine trouble warning light "iC"
9. Coolant temperature warning light "E"
10. Electric Power Steering warning light "EPS" (for EPS model)

Low-range indicator light "L"

This indicator light comes on when the transmission is in the low-range position.

High-range indicator light "H"

This indicator light comes on when the transmission is in the high-range position.

Neutral indicator light "N"

This indicator light comes on when the transmission is in the neutral position.

Reverse indicator light "R"

This indicator light comes on when the transmission is in the reverse position.

Park indicator light "P"

This indicator light comes on when the transmission is in the park position.

Coolant temperature warning light “”

This warning light comes on when the engine overheats. When this occurs during operation, stop the engine as soon as it is safe to do so and allow it to cool down for about 10 minutes.

The electrical circuit of the warning light can be checked by turning the key to “” (on). The warning light should come on for a few seconds, and then go off.

If the warning light does not come on initially when the key is turned to “” (on), or if the warning light remains on, have a Yamaha dealer check the electrical circuit.

NOTICE

- **The engine may overheat if the ATV is overloaded. In this case, reduce the load to specification.**
- **The engine may also overheat if mud or dirt has accumulated on the radiator (i.e., after riding in wet terrain). In this case, have a Yamaha dealer clean the radiator.**

- **Start the engine after making sure that the warning light is out. Continuous use while the warning light is on may cause damage to the engine.**

Engine trouble warning light “”

This warning light comes on or flashes when an electrical circuit monitoring the engine is not working correctly. When this occurs, have a Yamaha dealer check the self-diagnosis system. (See page 4-7 for an explanation of the self-diagnosis device.)

The electrical circuit of the warning light can be checked by turning the key to “” (on). The warning light should come on for a few seconds, and then go off.

If the warning light does not come on initially when the key is turned to “” (on), or if the warning light remains on, have a Yamaha dealer check the electrical circuit.

Electric Power Steering warning light “EPS” (for EPS model)

This warning light comes on when the key is turned to “” (on), and then goes off once the engine is started. If the warning light remains on or comes on after the engine is started, the EPS system may not be working correctly. When this occurs, have a Yamaha dealer check the EPS system.

The electrical circuit of the warning light can be checked by turning the key to “” (on). If the warning light does not come on, have a Yamaha dealer check the electrical circuit.

TIP

- If the engine is stopped using the engine stop switch and the key is in the “” (on) position, the EPS warning light comes on to indicate that the power assistance for the steering is not functioning.
- If the steering load is too heavy (i.e., excessive steering use when the ATV is traveling at a slow speed), the power assist is reduced to protect the EPS motor from overheating.

On-Command four-wheel-drive indicator “”, On-Command differential gear lock indicator “” and indicator light “DIFF. LOCK”

The On-Command four-wheel-drive indicator “” comes on when the On-Command four-wheel-drive switch is set to the “4WD” position.

The On-Command differential gear lock indicator “” and the On-Command differential gear lock indicator light “DIFF. LOCK” come on when the On-Command differential gear lock switch is set to the “LOCK” position.

TIP

- Due to the synchronizing mechanism in the differential gear case, the four-wheel-drive indicator may not come on until the ATV starts moving.
- When the On-Command differential gear lock switch is set to “LOCK” or “4WD”, the indicator “” and the indicator light “DIFF. LOCK” will flash until the differential gear is completely locked or unlocked. If the indicator and the indicator light continue to flash, the differential is not completely locked or unlocked. In this case, start moving to allow time for the differential to lock or unlock.

Multi-function display

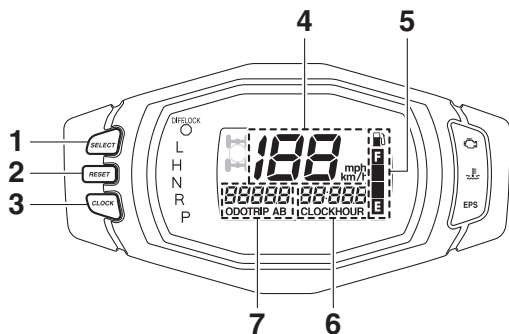

1. "SELECT" button
2. "RESET" button
3. "CLOCK" button
4. Speedometer
5. Fuel meter
6. Clock/Hour meter
7. Odometer/Tripmeter A/Tripmeter B

The multi-function display is equipped with the following:

- a speedometer
- an odometer
- two tripmeters (which show the distance traveled since they were last set to zero)
- a clock

- an hour meter (which shows the total time the engine has been running)
- a fuel meter
- a self-diagnosis device

Odometer and tripmeter modes

Pushing the "SELECT" button switches the display between the odometer mode "ODO" and the tripmeter modes "TRIP A" and "TRIP B" in the following order:

ODO → TRIP A → TRIP B → ODO

To reset a tripmeter, select it by pushing the "SELECT" button, and then push the "RESET" button for at least three seconds. The tripmeters can be used to estimate the distance that can be traveled with a full tank of fuel. This information will enable you to plan future fuel stops.

TIP

Pushing and holding in the "SELECT" button, and turning the key to "⏻" (on) while the button is pushed, switches the display between "mph" and "km/h".

Clock mode

Pushing the “CLOCK” button switches the display between the clock mode “CLOCK” and the hour meter mode “HOUR” in the following order:

CLOCK → HOUR → CLOCK

To set the clock

1. Set the display to the clock mode.
2. Push the “SELECT” button and “RESET” button together for at least three seconds.
3. When the hour digits start flashing, push the “RESET” button to set the hours.
4. Push the “SELECT” button, and the minute digits will start flashing.
5. Push the “RESET” button to set the minutes.
6. Push the “SELECT” button and then release it to start the clock.

Fuel meter

The fuel meter indicates the amount of fuel in the fuel tank. The display segments of the fuel meter disappear from “F” (full) towards “E” (empty) as the fuel level decreases. When the “E” segment disappears and the fuel level warning indicator flashes, refuel as soon as possible.

TIP

This fuel meter is equipped with a self-diagnosis system. If the electrical circuit is not working correctly, all the display segments and fuel level warning indicator will start flashing. If this occurs, have a Yamaha dealer check the electrical circuit.

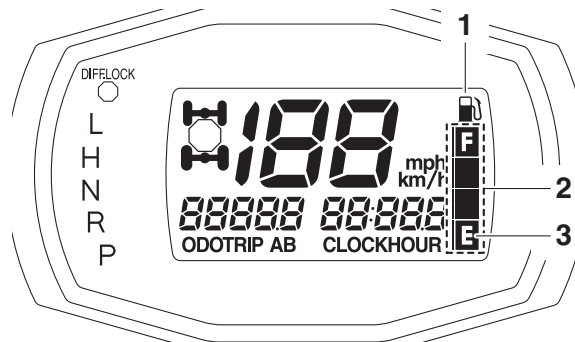

1. Fuel level warning indicator
2. Fuel meter
3. “E” segment

Self-diagnosis device

ECB00812

NOTICE

If the multi-function display indicates an error code, the vehicle should be checked as soon as possible in order to avoid engine damage.

EBU18065

Handlebar switches

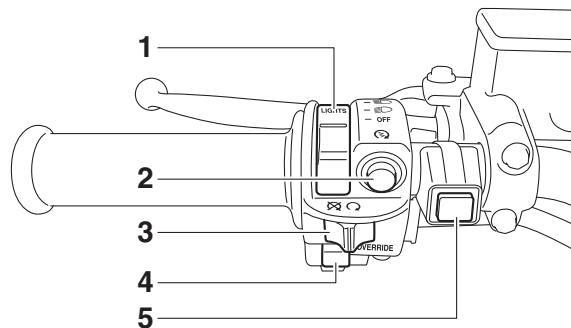

1. Light switch “/ /OFF”
2. Start switch “”
3. Engine stop switch “/ ”
4. Override switch “OVERRIDE”
5. Horn switch “”

4

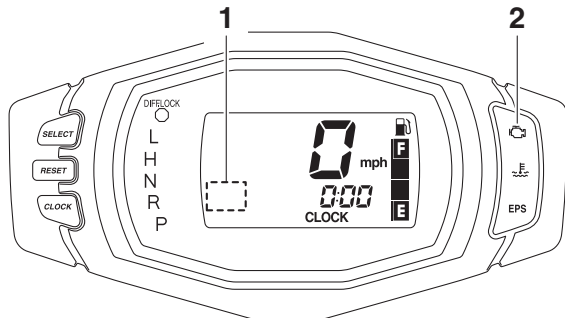

1. Error code display
2. Engine trouble warning light “”



This model is equipped with a self-diagnosis device for various electrical circuits.

If a problem is detected in any of those circuits, the engine trouble warning light will come on or flash and the multi-function display will indicate an error code.

If the multi-function display indicates an error code, note the code number, and then have a Yamaha dealer check the vehicle.

EBU18081

Engine stop switch “/”

Set this switch to “” before starting the engine. The engine stop switch controls the ignition and stops the engine when it is running. Use this switch to stop the engine in an emergency situation. The engine will not start or run when this switch is set to “”.



EBU18102

Start switch “”

Push this switch to crank the engine with the starter. See the starting instructions on page 6-1 prior to starting the engine.

EBU34120

Light switch “//OFF”

Set this switch to “” to turn on the left and right headlights (low beams) and the taillight. Set the switch to “” to turn on the left and right headlights (high beams), the center headlight, and the taillight. Set the switch to “OFF” to turn off all the lights.

ECB00044

NOTICE

Do not use the headlights with the engine turned off for an extended period of time, otherwise the battery may discharge to the point

that the starter motor will not operate properly. If this should happen, remove the battery and recharge it. (See page 8-54.)

EBU18171

Horn switch “”

Press the switch to sound the horn.

EBU18192

Override switch “**VERRIDE**”

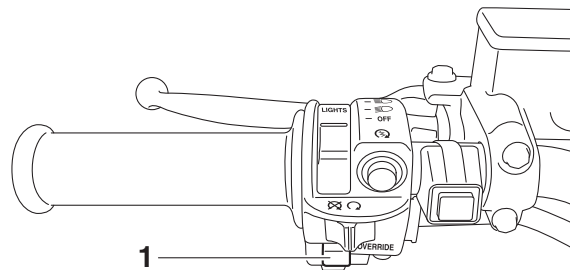

1. Override switch “**VERRIDE**”

Top speed is normally limited when operating in differential gear lock. If conditions require more engine power when riding forward, push and hold this switch to override the differential gear lock speed limiting function. (See page 4-10.) Releas-

ing the switch restores the speed limiting function. While the override switch is pushed, the segments of the speedometer digits will appear as shown in the figure.

4

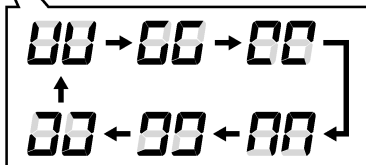
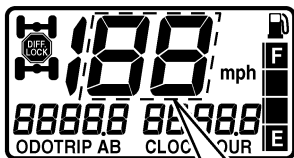

TIP

If the digits of the speedometer appear as shown when the switch is NOT being pushed, this could indicate a malfunction in the electrical system. In this case, take the ATV to a Yamaha dealer at the first opportunity.

EWB00151

! WARNING

Always ride at a slow speed when the ATV is in four-wheel-drive differential gear lock, and allow extra time and distance for maneuvers. All wheels turn at the same speed when the differential is locked, so it takes more effort to turn the ATV. The effort needed to turn increases with the riding speed. You may lose control and have an accident if you cannot make a sharp enough turn for the speed you are traveling.

EBU26608

On-Command four-wheel-drive switch "2WD"/"4WD"

EWB00164

! WARNING

Always stop the ATV before changing from two-wheel drive to four-wheel drive and vice versa. The ATV handles differently in two-wheel drive than in four-wheel drive in some circumstances. Changing from two-wheel drive to four-wheel drive or vice versa while moving may cause the ATV to unexpectedly

handle differently. This could distract the operator and increase the risk of losing control and of causing an accident.

This ATV is equipped with a switch to change from two-wheel drive to four-wheel drive and vice versa. Select the appropriate drive according to the terrain and the conditions.

- “2WD” (two-wheel drive): Power is supplied to the rear wheels.
- “4WD” (four-wheel drive): Power is supplied to the rear and front wheels.

To change from two-wheel drive to four-wheel drive, stop the ATV and push the switch in to the “4WD” position. Then, the four-wheel-drive indicator “” comes on in the multi-function display.

To change from four-wheel drive to two-wheel drive, stop the ATV and push the switch in to the “2WD” position.

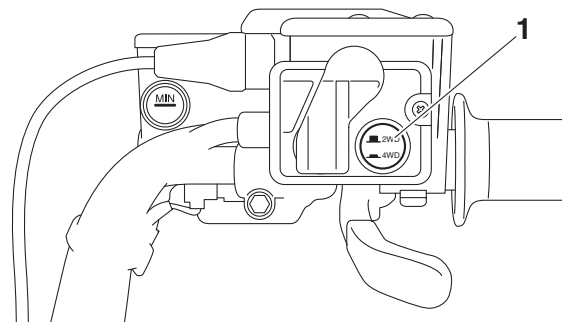

1. On-Command four-wheel-drive switch “2WD”/“4WD”

EBU30463

On-Command differential gear lock switch “4WD”/“LOCK”

EWB00132



Always stop the ATV before changing from four-wheel drive to four-wheel-drive differential gear lock or vice versa.

The ATV handles differently in four-wheel drive than in differential gear lock in some circumstances. Changing from four-wheel drive to differential gear lock or vice versa while moving may cause the ATV to handle differently un-

expectedly. This could distract the operator and increase the risk of losing control and causing an accident.

EWB00141

⚠ WARNING

Always ride at a slow speed when the ATV is in differential gear lock, and allow extra time and distance for maneuvers.

4

All wheels turn at the same speed when the differential gear is locked, so it takes more effort to turn the ATV. The effort needed to turn increases with the riding speed. You may lose control and have an accident if you cannot make a sharp enough turn for the speed you are traveling.

This ATV is equipped with a switch allowing you to lock the differential gear when in four-wheel drive. Select the appropriate switch position according to the terrain and the conditions.

- “4WD” (four-wheel drive): Power is supplied to the rear and front wheels.

- “LOCK” (four-wheel drive with the differential gear locked): Power is supplied to the rear and front wheels and the differential gear is locked. Unlike in four-wheel drive, all wheels turn at the same speed.

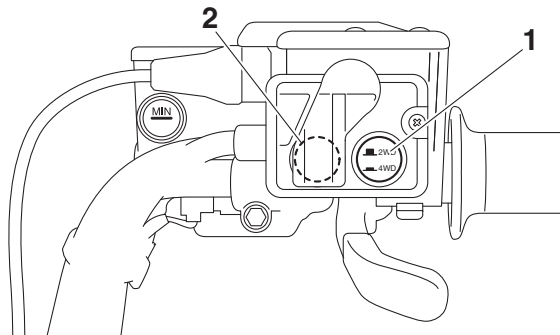

1. On-Command four-wheel-drive switch “2WD”/“4WD”
2. On-Command differential gear lock switch “4WD”/“LOCK”

To lock the differential gear in four-wheel drive, make sure the On-Command four-wheel-drive switch is pushed in to the “4WD” position.

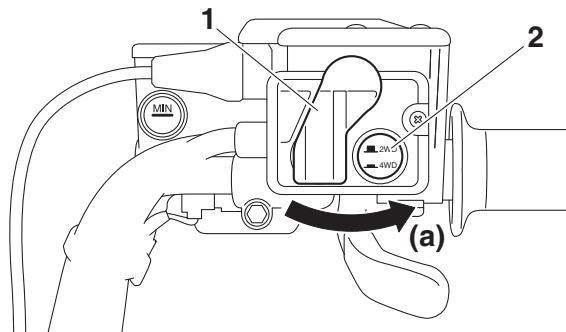

1. Differential gear lock lever
2. On-Command four-wheel-drive switch “2WD”/“4WD”

Stop the ATV, move the differential gear lock lever to position (a), and then push the differential gear lock switch in to the “LOCK” position. When the differential gear is locked, the differential gear lock indicator light “DIFF. LOCK” will come on along with the indicator “” in the multi-function display.

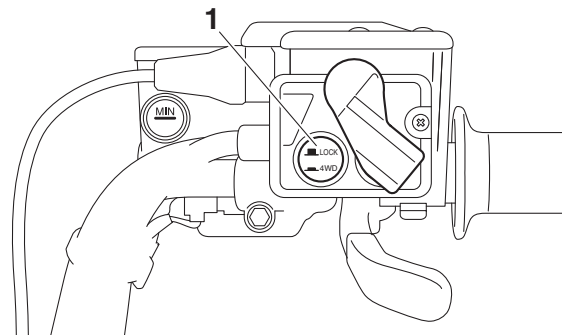

1. On-Command differential gear lock switch “4WD”/“LOCK”

To unlock the differential gear, stop the ATV and push the switch to the “4WD” position.

TIP

- When the switch is set to “LOCK” or “4WD”, the differential gear lock indicator and indicator light will flash until the differential gear is completely locked or unlocked.
- When the indicator and indicator light are flashing, turning the handlebar back and forth will help the differential gear lock to engage or disengage.

- Riding before the differential gear is properly engaged or disengaged (e.g., when the indicator and indicator light are flashing) will cause the vehicle speed to be limited until the differential gear is completely engaged or disengaged.
- When the ATV is in four-wheel-drive differential gear lock, the maximum traveling speed is limited to 35 km/h (22 mi/h). However, if conditions require full engine power to be available, push and hold the override switch to disable the differential gear lock speed limiter. (See page 4-8 for a detailed explanation of this switch.)

EBU18283

Throttle lever

Once the engine is running, pushing the throttle lever will increase the engine speed.

Regulate the speed of the ATV by varying the throttle position. Because the throttle is spring-loaded, the ATV will decelerate, and the engine will return to an idle any time the throttle lever is released.

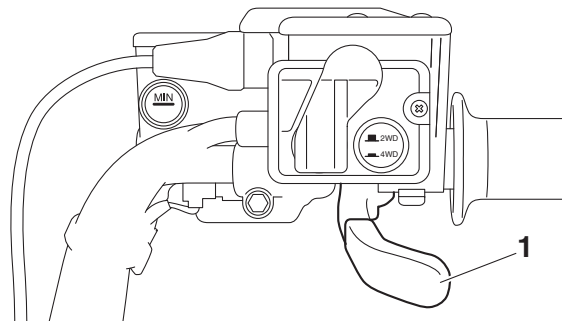

1. Throttle lever

Before starting the engine, check the throttle to be sure it is operating smoothly. Make sure it returns to the idle position as soon as the lever is released.

EBU18324

Speed limiter

Your ATV is equipped with an adjustable speed limiter. The speed limiter keeps the throttle from fully opening, even when the throttle lever is pushed to the maximum.

1. Loosen the locknut.
2. To increase the maximum engine power available and the maximum speed of the ATV, turn the adjusting screw in direction (a). To

decrease the maximum engine power available and the maximum speed of the ATV, turn the adjusting screw in direction (b). Do not turn the adjusting screw out more than 12 mm (0.47 in) or the throttle cable could be damaged. Always make sure the throttle lever free play is adjusted to 3.0–5.0 mm (0.12–0.20 in). (See page 8-42.) **WARNING! Improper adjustment of the speed limiter and throttle could cause throttle cable damage or improper throttle operation. You could lose control, resulting in an accident.**

[EWB00242]

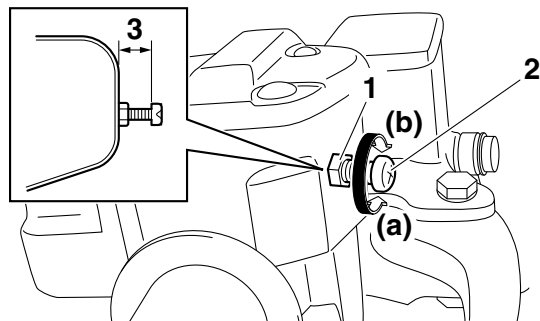

1. Locknut
2. Adjusting screw
3. No more than 12 mm (0.47 in)

3. Tighten the locknut.

EBU18392

Front brake lever

The front brake lever is located on the right handlebar. To apply the front brake, pull the brake lever toward the handlebar grip.

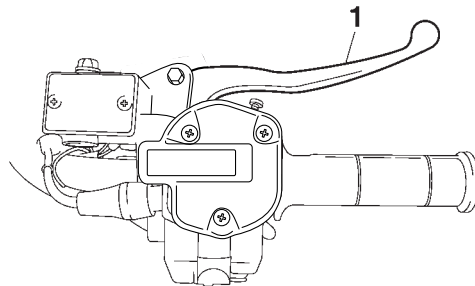

1. Front brake lever

EBU18443

Brake pedal and rear brake lever

The brake pedal is located on the right side of the ATV and the rear brake lever is located on the left handlebar. To apply the rear brake, push down on the brake pedal or pull the brake lever toward the handlebar grip.

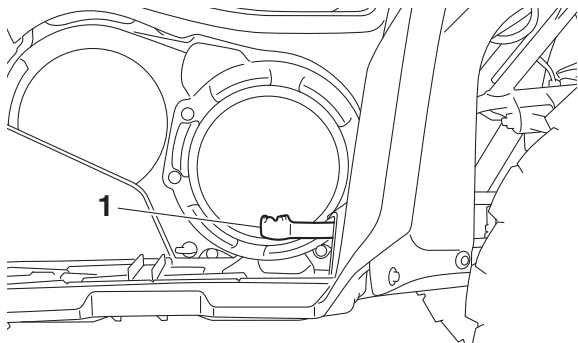

1. Brake pedal

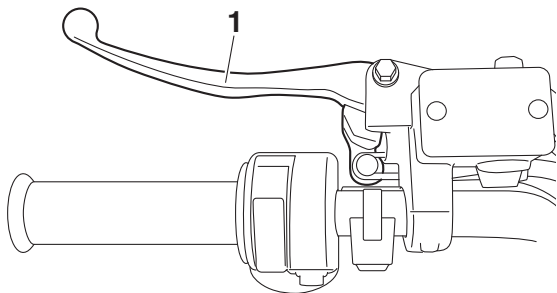

1. Rear brake lever

EBU18612

Drive select lever

The drive select lever is used to shift your ATV into the low-range, high-range, neutral, reverse and park positions. See the “Operating the drive select lever and driving in reverse” section on page 6-2 for the drive select lever operation.

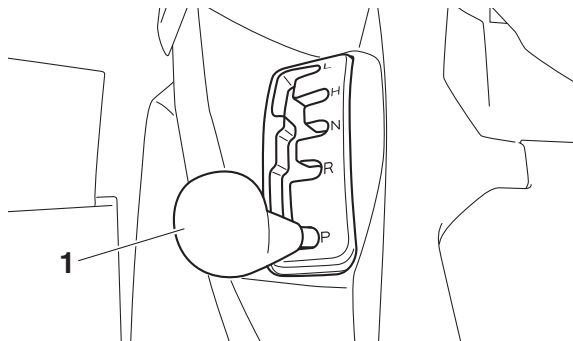

1. Drive select lever

EBU18721

Fuel tank cap

Remove the fuel tank cap by turning it counter-clockwise.

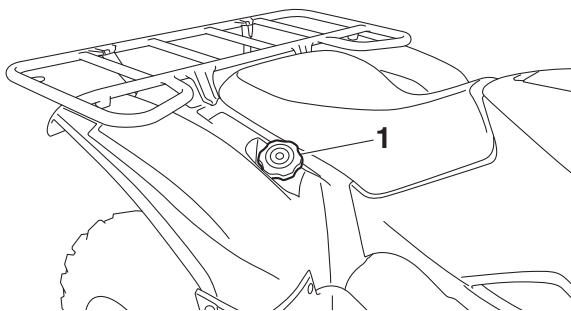

1. Fuel tank cap

EBU18757

Fuel

Make sure there is sufficient gasoline in the tank.

EWB02522



WARNING

Gasoline and gasoline vapors are extremely flammable. To avoid fires and explosions and to reduce the risk of injury when refueling, follow these instructions.

1. Before refueling, turn off the engine and be sure that no one is sitting on the vehicle. Never refuel while smoking, or while in the vicinity

of sparks, open flames, or other sources of ignition such as the pilot lights of water heaters and clothes dryers.

2. Do not overfill the fuel tank. When refueling, be sure to insert the pump nozzle into the fuel tank filler hole. Stop filling when the fuel reaches the bottom of the filler tube. Because fuel expands when it heats up, heat from the engine or the sun can cause fuel to spill out of the fuel tank.

4

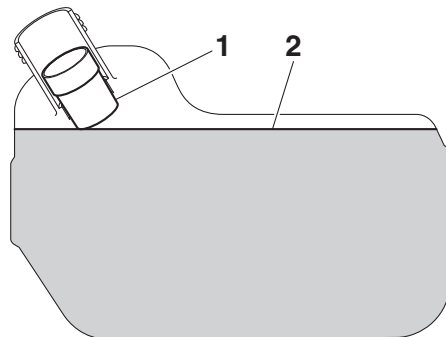

1. Fuel tank filler tube
2. Maximum fuel level

Recommended fuel:

Regular unleaded gasoline only

For Europe: Regular unleaded gasoline only with a research octane number of 95 or higher

Fuel tank capacity:

18 L (4.75 US gal, 3.96 Imp.gal)

Fuel reserve amount:

4 L (1.06 US gal, 0.88 Imp.gal)

3. Wipe up any spilled fuel immediately.

NOTICE: Immediately wipe off spilled fuel with a clean, dry, soft cloth, since fuel may deteriorate painted surfaces or plastic parts. [ECB00982]

4. Turn the fuel tank cap fully clockwise to make sure it is securely closed.

EWB02532



Gasoline is poisonous and can cause injury or death. Handle gasoline with care. Never siphon gasoline by mouth. If you should swallow some gasoline or inhale a lot of gasoline vapor, or get some gasoline in your eyes, see your doctor

immediately. If gasoline spills on your skin, wash with soap and water. If gasoline spills on your clothing, change your clothes.

ECB00071

NOTICE

Use only unleaded gasoline. The use of leaded gasoline will cause severe damage to internal engine parts, such as the valves and piston rings, as well as to the exhaust system.

Your Yamaha engine has been designed to use regular unleaded gasoline with a research octane number of 91 or higher (95 or higher for Europe). If knocking (or pinging) occurs, use a gasoline of a different brand. Use of unleaded fuel will extend spark plug life and reduce maintenance costs.

EBU34140

Seat**To remove the seat**

Pull up the seat at the rear, and then pull the seat rearward.

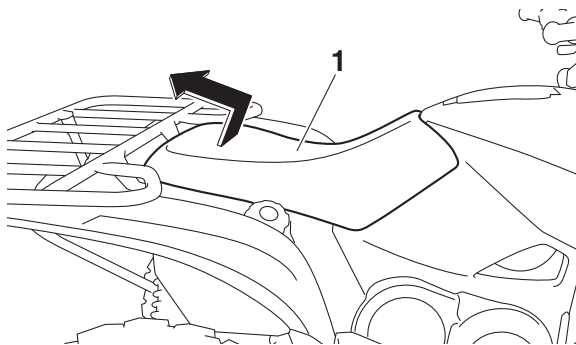

1. Seat

To install the seat

Insert the projections on the front of the seat into the seat holders and push down on the seat at the rear. Make sure that the seat is securely fitted.

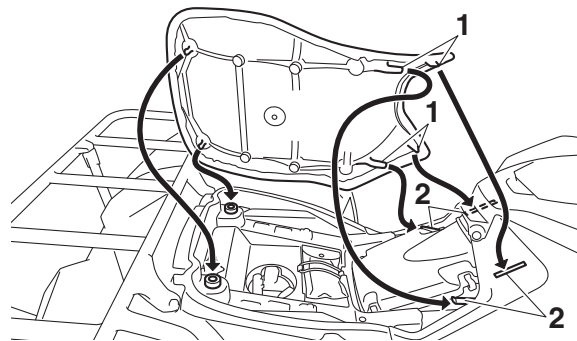

- 1. Projection
- 2. Seat holder

EBU34681

Storage compartments

This ATV is equipped with three storage compartments.

ECB00831

NOTICE

Do not store metal or sharply edged objects, like tools, in the storage compartments. If they must be stored, wrap them in appropriate cushion material to prevent damaging the storage compartments.

The front storage compartment is located at the front right side of the ATV. To access the storage compartment, remove the storage compartment cover by turning it counterclockwise.

4

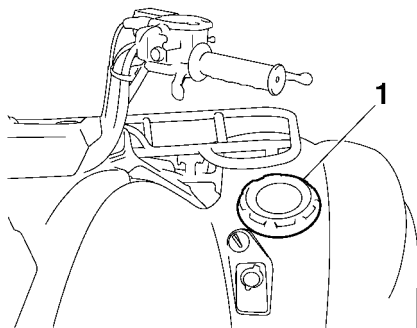

1. Front storage compartment cover

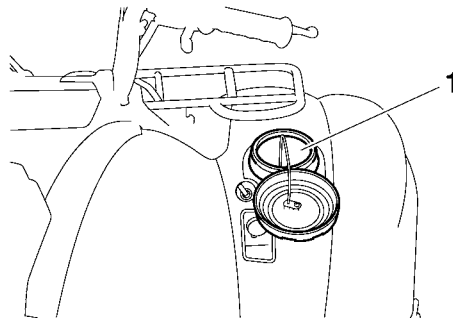

1. Front storage compartment

The center storage compartment is located in front of the seat. To access the storage compartment, open the storage compartment lid.

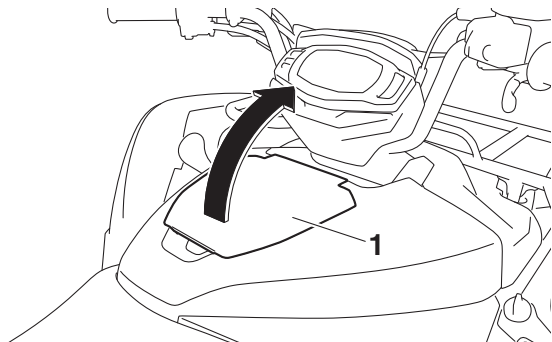

1. Center storage compartment lid

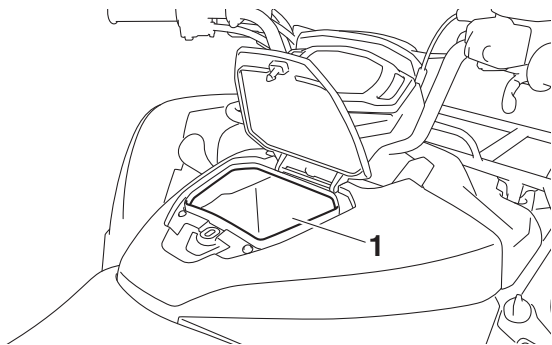

1. Center storage compartment

The rear storage compartment is located under the taillight. To access the storage compartment, open the storage compartment lid by turning the storage compartment knob 1/4 turn counterclockwise.

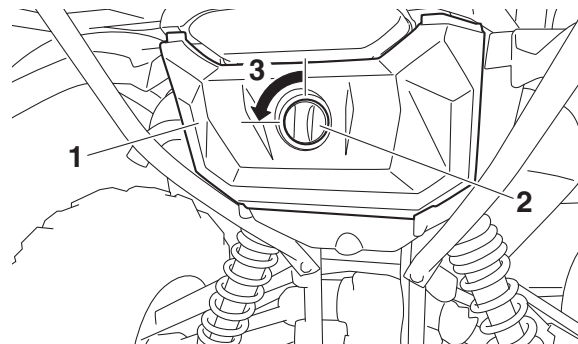

1. Rear storage compartment lid
2. Rear storage compartment knob
3. Open.

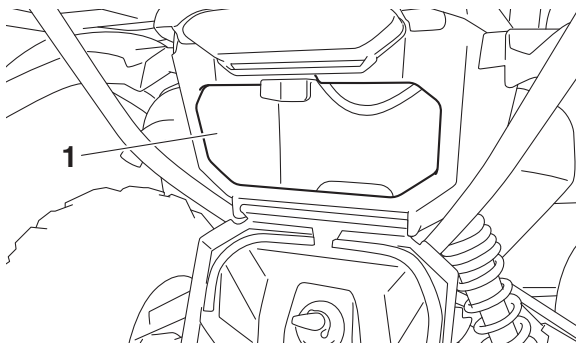

1. Rear storage compartment

When storing any documents in the storage compartments, be sure to wrap them in a plastic bag so that they will not get wet. When washing the ATV, be careful not to let any water enter the storage compartments.

- Do not exceed the load limit of 0.5 kg (1 lb) for the front storage compartment, 4.0 kg (9 lb) for the center storage compartment or 2.0 kg (4 lb) for the rear storage compartment.
- Do not exceed the maximum load of 240.0 kg (530 lb) for the ATV.

TIP

A drain plug is fitted at the bottom of each storage compartment. If any water collects in a storage compartment, remove the drain plug, drain the water, and then install the drain plug.

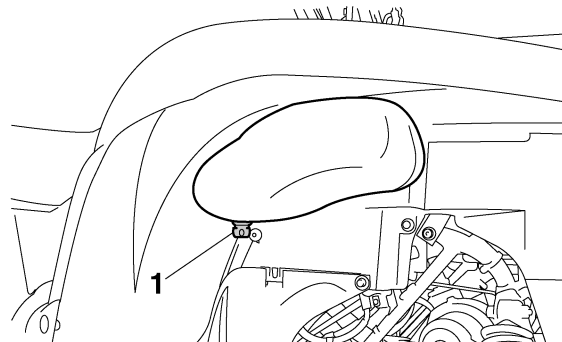

1. Front storage compartment drain plug

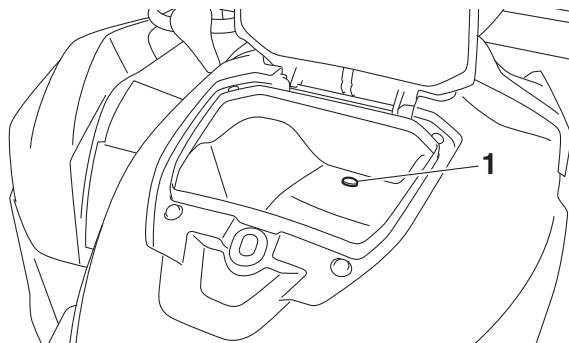

1. Center storage compartment drain plug

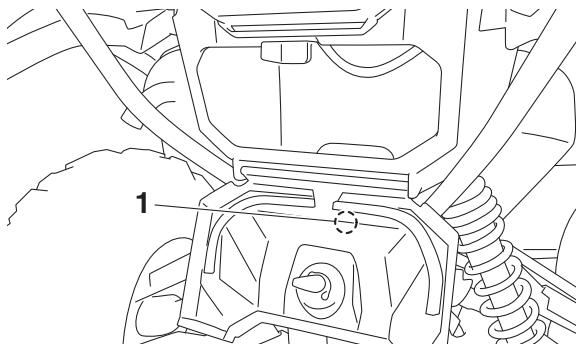

1. Rear storage compartment drain plug

EBU18963

Front carrier

- Do not exceed the load limit of 50.0 kg (110 lb) for the front carrier.
- Do not exceed the maximum load of 240.0 kg (530 lb) for the ATV.

EBU18973

Rear carrier

- Do not exceed the load limit of 90.0 kg (198 lb) for the rear carrier.
- Do not exceed the maximum load of 240.0 kg (530 lb) for the ATV.

EBU19148

Adjusting the front and rear shock absorber assemblies

The spring preload can be adjusted to suit the rider's weight and the riding conditions.

EWB00401



WARNING

Always adjust the shock absorber assemblies on the left and right side to the same setting. Uneven adjustment can cause poor handling and loss of stability, which could lead to an accident.

Adjust the spring preload as follows.

Turn the spring preload adjusting ring in direction (a) to increase the spring preload and thereby harden the suspension, and in direction (b) to decrease the spring preload and thereby soften the suspension.

Align the appropriate notch in the adjusting ring with the position indicator on the shock absorber.

4

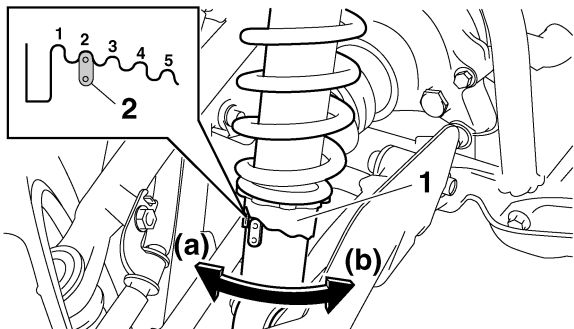

1. Spring preload adjusting ring
2. Position indicator

TIP _____
A special wrench can be obtained at a Yamaha dealer to make this adjustment.

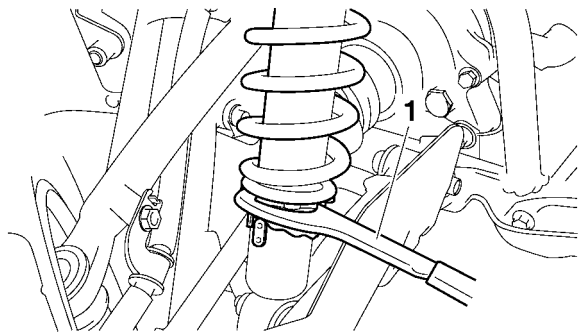

1. Special wrench

Spring preload setting:

Minimum (soft):

1

Standard:

2

Maximum (hard):

5

EBU28972

**Trailer hitch (YFM70GPSG /
YFM70GPLG)**

This ATV is equipped with a 5 cm (2 in) trailer hitch receiver.

Trailer towing equipment can be obtained at a Yamaha dealer. (See page 6-7 for precaution information.)

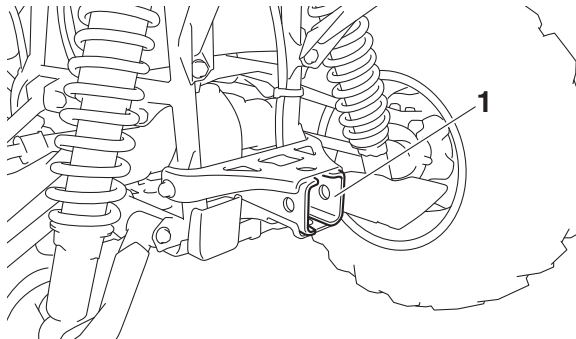

1. Trailer hitch receiver

EBU19184

Auxiliary DC jack

The auxiliary DC jack is located at the front right side of the ATV. The auxiliary DC jack can be used for suitable work lights, radios, etc. The auxiliary DC jack should only be used when the engine is running and the light switch is set to "OFF".

1. Set the light switch to "OFF".
2. Turn the accessory off.
3. Start the engine. (See page 6-1.)

4. Open the auxiliary DC jack cap, and then insert the accessory power plug into the jack.

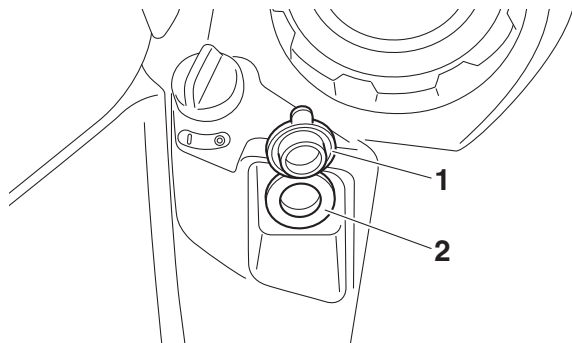

1. Auxiliary DC jack cap
2. Auxiliary DC jack

Maximum rated capacity for the auxiliary DC jack:

DC 12 V, 10 A (120 W)

5. Turn the accessory on.
6. When the auxiliary DC jack is not being used, cover it with the cap.

NOTICE

- Do not use accessories requiring more than the above maximum capacity. This may overload the circuit and cause the fuse to blow.
 - If accessories are used without the engine running or with the headlights turned on, the battery will lose its charge and engine starting may become difficult.
 - Do not use an automotive cigarette lighter or other accessories with a plug that gets hot because the jack can be damaged.
-

PRE-OPERATION CHECKS

Inspect your vehicle each time you use it to make sure the vehicle is in safe operating condition. Always follow the inspection and maintenance procedures and schedules described in the Owner's Manual.

EWB00482



Failure to inspect or maintain the vehicle properly increases the possibility of an accident or equipment damage. Do not operate the vehicle if you find any problem. If a problem cannot be corrected by the procedures provided in this manual, have the vehicle inspected by a Yamaha dealer.

5

Before using this vehicle, check the following points:

ITEM	ROUTINE	PAGE
Fuel	<ul style="list-style-type: none"> • Check fuel level in fuel tank, and add recommended fuel if necessary. • Check fuel line for leakage. Correct if necessary. 	4-16, 5-3
Engine oil	<ul style="list-style-type: none"> • Check oil level in engine, and add recommended oil to specified level if necessary. • Check ATV for oil leakage. Correct if necessary. 	5-3, 8-21
Final gear oil	<ul style="list-style-type: none"> • Check ATV for oil leakage. Correct if necessary. 	5-3, 8-25
Differential gear oil	<ul style="list-style-type: none"> • Check ATV for oil leakage. Correct if necessary. 	5-3, 8-28
Coolant	<ul style="list-style-type: none"> • Check coolant level in reservoir, and add recommended coolant to specified level if necessary. • Check cooling system for leakage. Correct if necessary. 	5-3, 8-30

ITEM	ROUTINE	PAGE
Front brake	<ul style="list-style-type: none"> • Check operation. If soft or spongy, have Yamaha dealer bleed hydraulic system. • Check brake pads for wear, and replace if necessary. • Check brake fluid level in reservoir, and add specified brake fluid to specified level if necessary. • Check hydraulic system for leakage. Correct if necessary. 	5-3, 8-44, 8-45, 8-46
Rear brake	<ul style="list-style-type: none"> • Check operation. If soft or spongy, have Yamaha dealer bleed hydraulic system. • Check pedal free play, and adjust if necessary. • Check brake pads for wear, and replace if necessary. • Check brake fluid level in reservoir, and add specified brake fluid to specified level if necessary. • Check hydraulic system for leakage. Correct if necessary. 	5-3, 8-44, 8-45, 8-46, 8-47
Throttle lever	<ul style="list-style-type: none"> • Make sure that operation is smooth. Lubricate cable and lever housing if necessary. • Check lever free play, and adjust if necessary. 	5-4, 8-42
Control cables	<ul style="list-style-type: none"> • Make sure that operation is smooth. Lubricate if necessary. 	8-50
Wheels and tires	<ul style="list-style-type: none"> • Check wheel condition, and replace if damaged. • Check tire condition and tread depth. Replace if necessary. • Check air pressure. Correct if necessary. 	5-4
Brake pedal	<ul style="list-style-type: none"> • Make sure that operation is smooth. Lubricate pedal pivoting point if necessary. 	8-51
Brake levers	<ul style="list-style-type: none"> • Make sure that operation is smooth. Lubricate lever pivoting points if necessary. 	8-50
Axle boots	<ul style="list-style-type: none"> • Check for cracks or damage, and replace if necessary. 	8-49
Chassis fasteners	<ul style="list-style-type: none"> • Make sure that all nuts, bolts and screws are properly tightened. 	5-6
Instruments, lights and switches	<ul style="list-style-type: none"> • Check operation, and correct if necessary. 	5-7

EBU19542

Fuel

Make sure that there is sufficient fuel in the tank. (See page 4-16.)

EBU19561

Engine oil

Make sure that the engine oil is at the specified level. Add oil as necessary. (See page 8-21.)

EBU19591

Final gear oil

Make sure that the final gear oil is at the specified level. Add oil as necessary. (See page 8-25.)

EBU19601

Differential gear oil

Make sure that the differential gear oil is at the specified level. Add oil as necessary. (See page 8-28.)

EBU19632

Coolant

Make sure that the coolant is at the specified level. Add coolant as necessary. (See page 8-30.)

TIP

The coolant level must be checked on a cold engine since the level varies with engine temperature.

EBU29083

Front and rear brakes

Brake levers and brake pedal

- Check that there is no free play in the front and rear brake levers. If there is free play, have a Yamaha dealer check the brake system.
- Check for correct free play in the brake pedal. If the free play is incorrect, adjust it. (See page 8-47.)
- Check the operation of the brake levers and pedal. They should move smoothly and there should be a firm feeling when the brakes are applied. If not, have a Yamaha dealer check the brake system.

Brake fluid level

Check the brake fluid level. Add fluid if necessary. (See page 8-45.)

Specified brake fluid:
DOT 4

Brake fluid leakage

Check to see if any brake fluid is leaking out of the pipe joints or brake fluid reservoirs. Apply the brakes firmly for one minute. If a lever moves slowly inward, there may be a leak in the brake system. If there is any leakage, the brake system should be checked by a Yamaha dealer.

Brake operation

Test the brakes at slow speed after starting out to make sure they are working properly. If the brakes do not provide proper braking performance, check the brake pads for wear. (See page 8-44.)

EBU19762

Throttle lever

Check the operation of the throttle lever. It must open smoothly and spring back to the idle position when released. Have a Yamaha dealer correct if necessary.

EBU19815

Tires

Check tire pressure regularly to make sure it is at the recommended specifications. Also check for wear and damage.

Tire pressure

Use the low-pressure tire gauge to check and adjust tire pressures when the tires are cold. Tire pressures must be equal on both sides.

WARNING! Operation of this vehicle with improper tire pressure may cause severe injury or death from loss of control or rollover. Tire pressure below the minimum specified could also cause the tire to dislodge from the rim under severe riding conditions. [EWB02542] Set tire pressures to the following specifications:

Recommended tire pressure:

Front

35.0 kPa (0.350 kgf/cm², 5.0 psi)

Rear

30.0 kPa (0.300 kgf/cm², 4.4 psi)

Minimum tire pressure:

Front

32.0 kPa (0.320 kgf/cm², 4.6 psi)

Rear

27.0 kPa (0.270 kgf/cm², 4.0 psi)

Maximum tire seating pressure:

Front

250 kPa (2.5 kgf/cm², 36 psi)

Rear

250 kPa (2.5 kgf/cm², 36 psi)

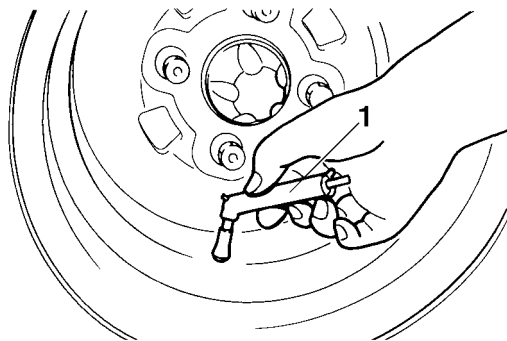

1. Low-pressure tire gauge

Tire wear limit

When the tire groove decreases to 3 mm (0.12 in) due to wear, replace the tire.

The low-pressure tire gauge is included as standard equipment. Make two measurements of the tire pressure and use the second reading. Dust or dirt in the gauge could cause the first reading to be incorrect.

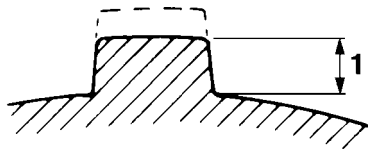

5

1. Tire wear limit

Tire information

This ATV is equipped with tubeless tires with valves.

EWB02552



Use of improper tires on this ATV may cause loss of control, increasing your risk of an accident.

After extensive tests, only the tires listed below have been approved for this model by Yamaha Motor Manufacturing Corporation of America.

Front:

Manufacturer/model:
MAXXIS/MU05Y

Size:
AT26 x 8-12

Type:
Tubeless

Rear:

Manufacturer/model:
MAXXIS/MU06Y

Size:
AT26 x 10-12

Type:
Tubeless

Aftermarket tires and rims

The tires and rims that came with your ATV were designed to match the performance capabilities and to provide the best combination of handling, braking, and comfort. Other tires, rims, sizes, and combinations may not be appropriate.

EBU19841

Chassis fasteners

Make sure that all nuts, bolts and screws are properly tightened.

Instruments, lights and switches

Check that all instruments, lights and switches are working properly. Correct if necessary.

OPERATION

Read the Owner's Manual carefully before riding the ATV. If there is a control or function you do not understand, ask your Yamaha dealer.

EWB00632

WARNING

Read the Owner's Manual carefully to become familiar with all controls in order to help prevent any loss of control, which could cause an accident or injury.

6



EBU30561

Starting the engine

ECB00151

NOTICE

See the "Engine break-in" section on page 6-4 prior to operating the engine for the first time.

1. Turn the key to "  " (on) and the engine stop switch to "  ".

The following warning lights should come on for a few seconds, then go off.

- Coolant temperature warning light

- Engine trouble warning light

The EPS warning light should come on, then go off when the engine is started. (for EPS model)

ECB00825

NOTICE

If a warning light does not go off, see page 4-2 for the corresponding warning light circuit check. To avoid possible damage, do not operate the ATV if a warning light stays on.

2. Apply the brake pedal, and then shift the drive select lever into the neutral or park position. The corresponding indicator light should come on. If the indicator light does not come on, have a Yamaha dealer check the electrical circuit.

TIP

This model is equipped with an ignition circuit cut-off system. The engine can be started under the following conditions:

- The drive select lever is in the neutral or park position.

- The rear brake lever or brake pedal is applied with the drive select lever in any position. However, it is recommended to shift into the neutral or park position before starting the engine.

3. Apply the rear brake lever or brake pedal.
4. Completely close the throttle lever and start the engine by pushing the start switch.

TIP

If the engine fails to start, release the start switch, then push it again. Pause a few seconds before the next attempt. Each cranking should be as short as possible to preserve battery energy. Do not crank the engine more than 10 seconds on each attempt.

ECB00164

NOTICE

For maximum engine life, never accelerate hard when the engine is cold!

EBU20442

Operating the drive select lever and driving in reverse

ECB00171

NOTICE

Before shifting, stop the ATV, otherwise the transmission may be damaged.

Shifting: Neutral to High-range and High-range to Low-range

1. Bring the ATV to a complete stop.
2. Apply the brake pedal, and then shift by moving the drive select lever along the shift guide.

TIP

Make sure that the drive select lever is completely shifted into position.

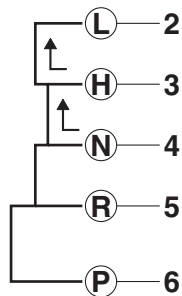
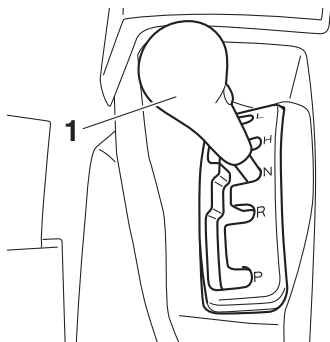

6

1. Drive select lever
2. L (Low-range)
3. H (High-range)
4. N (Neutral)
5. R (Reverse)
6. P (Park)

3. Release the brake pedal, and then open the throttle lever gradually.

Shifting: Neutral to Reverse and Reverse to Park

EWB00721



Improper operation in reverse could make you hit an obstacle or even a person behind you, resulting in serious injury. When you shift into

reverse, make sure there are no people or obstacles behind you. When it is safe to proceed, go slowly.

1. Bring the ATV to a complete stop.
2. Apply the brake pedal. The drive select lever cannot be shifted into or from reverse or park without applying the brake pedal.
3. Shift from neutral to reverse or from reverse to park and vice versa by moving the drive select lever along the shift guide.

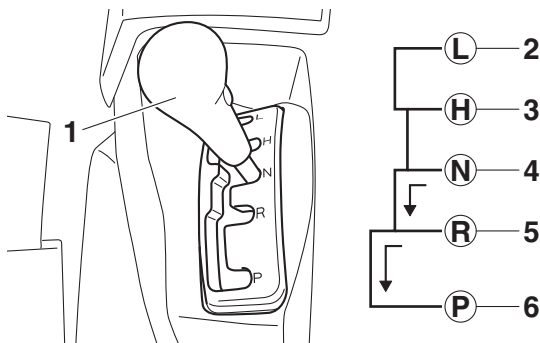

1. Drive select lever
2. L (Low-range)
3. H (High-range)
4. N (Neutral)
5. R (Reverse)
6. P (Park)

TIP

- When in reverse, the reverse indicator light should come on. If the indicator light does not come on, have a Yamaha dealer check the electrical circuit.
- Due to the synchronizing mechanism in the engine, the indicator light may not come on until the ATV starts moving.

4. Check behind for people or obstacles, and then release the brake pedal.
5. Open the throttle lever gradually and continue to watch to the rear while backing.

EBU20683

Engine break-in

TIP

- For ATVs equipped with an odometer or an hour meter, follow the figures given in km (mi) or the figures given in hours.
- For ATVs not equipped with an odometer or hour meter, follow the figures given in hours.

There is never a more important period in the life of your engine than the first 320 km (200 mi) or 20 hours of riding. For this reason, you should read the following material carefully.

Since the engine is brand new, do not put an excessive load on it for the first 320 km (200 mi) or 20 hours. The various parts in the engine wear and polish themselves to the correct operating clearances. During this period, prolonged full-throttle operation or any condition that might result in engine overheating must be avoided.

0–160 km (0–100 mi) or 0–10 hours

Avoid prolonged operation above 1/2 throttle. Vary the speed of the ATV regularly. Do not operate it at one set throttle position.

160–320 km (100–200 mi) or 10–20 hours

Avoid prolonged operation above 3/4 throttle. Rev the engine freely, but do not use full throttle at any time.

320 km (200 mi) or 20 hours and beyond

The ATV can now be operated normally.

ECB00221

NOTICE

If any engine trouble should occur during the engine break-in period, immediately have a Yamaha dealer check the ATV.

EBU27322

Parking

When parking the ATV, stop the engine, and shift the drive select lever into the park position.

EBU29901

Parking on a slope

EWB00861



Avoid parking on hills or other inclines. Parking on a hill or other incline could cause the ATV to roll out of control, increasing the chance of an accident. If you must park on an incline, place the ATV transversely across the incline, stop the engine, shift the drive select lever to the park position, and then block the front and rear wheels with rocks or other objects.

Do not park the ATV at all on hills that are so steep you could not walk up them easily.

1. Bring the ATV to a stop by applying the brakes.
2. Stop the engine.
3. With the brake pedal applied, shift the drive select lever to the park position.

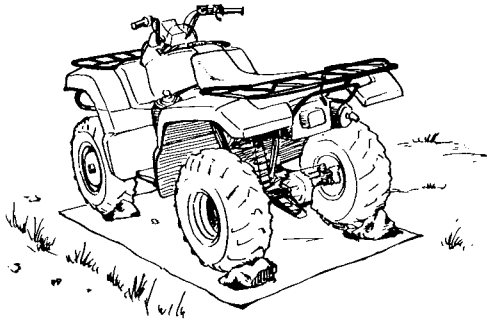

EBU20911

Accessories and loading

EBU20922

Genuine Yamaha Accessories

Choosing accessories for your ATV is an important decision. Genuine Yamaha Accessories, which are available only from a Yamaha dealer, have been designed, tested, and approved by Yamaha for use on your ATV. Many companies with no connection to Yamaha manufacture parts and accessories or offer other modifications for Yamaha vehicles. Yamaha is not in a position to test the products that these aftermarket companies produce. Therefore, Yamaha can neither endorse nor recommend the use of accessories not

sold by Yamaha or modifications not specifically recommended by Yamaha, even if sold and installed by a Yamaha dealer.

Aftermarket parts, accessories, and modifications

While you may find aftermarket products similar in design and quality to genuine Yamaha Accessories, recognize that some aftermarket accessories or modifications are not suitable because of potential safety hazards to you or others. Installing aftermarket products or having other modifications performed to your ATV that change any of the vehicle's design or operation characteristics can put you and others at greater risk of serious injury or death. You are responsible for injuries related to changes in the vehicle.

Keep the following in mind when considering an accessory or operating an ATV which has accessories.

- Accessories should be rigidly and securely mounted. An accessory which can shift position or come off while you are riding could affect your ability to control the ATV.
- Do not mount an accessory where it could interfere with your ability to control the ATV. Examples include (but are not limited to) a heavy or

bulky object attached to the handlebars which could make steering difficult, an accessory that limits your ability to move around on the seat, or one that limits your view.

- Use extra caution when riding an ATV with accessories. The ATV may handle differently than it does without accessories.

EBU34691

Loading

EWB00821



6

Never exceed the stated load capacity for this ATV. Overloading this ATV or carrying or towing cargo improperly could cause changes in ATV handling which could lead to an accident. Cargo should be properly distributed and securely attached. Reduce speed when carrying cargo or pulling a trailer. Allow greater distance for braking.

Cargo or a trailer can change the stability and handling of an ATV.

You must use common sense and good judgment when carrying cargo or towing a trailer. Keep the following points in mind:

- Never exceed the weight limits shown. An overloaded ATV can be unstable.

MAXIMUM LOADING LIMIT

ATV loading limit (total weight of rider, cargo, accessories, and tongue):

240.0 kg (530 lb)

Front carrier:

50.0 kg (110 lb)

Rear carrier:

90.0 kg (198 lb)

Front storage compartment:

0.5 kg (1 lb)

Center storage compartment:

4.0 kg (9 lb)

Rear storage compartment:

2.0 kg (4 lb)

Trailer hitch:

Pulling load (total weight of trailer and cargo):

5880 N (600 kgf, 1322 lbf)

Tongue weight (vertical weight on trailer hitch point):

147 N (15 kgf, 33 lbf)

- Do not exceed the maximum tongue weight. You can measure tongue weight with a bathroom scale. Put the tongue of the loaded trailer on the scale with the tongue at hitch height. Adjust the load in the trailer, if necessary, to reduce the weight on the hitch. If you are carrying cargo and towing a trailer, include the tongue weight in the maximum ATV load limit.
- Load cargo on the carriers as close to the center of the ATV as possible. Put cargo at the rear of the front carrier, at the front of the rear carrier, and center it.
- Tie down cargo securely to the carriers. Make sure cargo in the trailer cannot move around. A shifting load can cause an accident.
- Make sure the load does not interfere with controls or your ability to see where you are going.
- Ride more slowly than you would without a load. The more weight you carry, the slower you should go. Although conditions vary, it is good practice not to exceed low range whenever you are carrying heavier loads or when towing a trailer.
- Allow more braking distance. A heavier ATV takes longer to stop.
- Avoid making sharp turns unless at very slow speeds.
- Avoid hills and rough terrain. Choose terrain carefully. Added weight affects the stability and handling of the ATV.

RIDING YOUR ATV

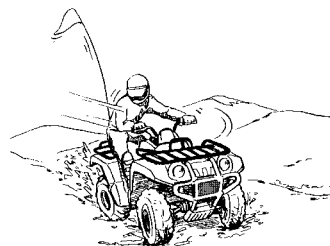
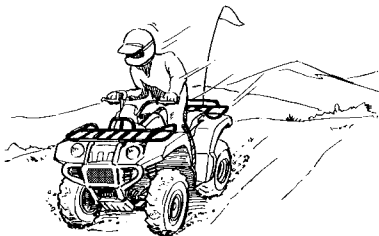
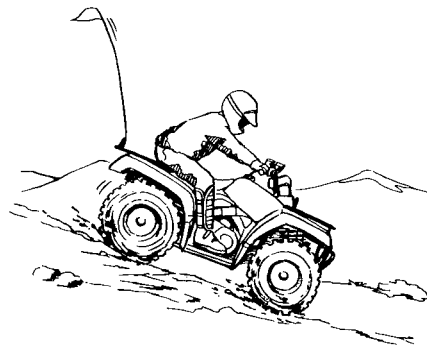
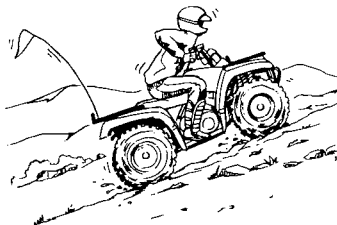
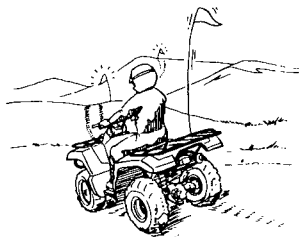

GETTING TO KNOW YOUR ATV

This ATV is mainly for utility use, but may also be used for recreation. This section, Riding your ATV, provides general ATV riding instructions for recreational riding. The skills and techniques described in this section, however, are appropriate for all types of riding. Riding your ATV requires special skills acquired through practice over a period of time. Take the time to learn the basic techniques well before attempting more difficult maneuvers. Riding your new ATV can be a very enjoyable activity, providing you with hours of pleasure. But it is essential to familiarize yourself with the operation of the ATV to achieve the skill necessary to enjoy riding safely. Before you begin to ride, be sure you have read this Owner's Manual completely and understand the operation of the controls. Pay particular attention to the safety information on pages 2-1–2-6. Also read all warning and notice labels on your ATV.

RIDE WITH CARE AND GOOD JUDGMENT

Get training if you are inexperienced.

EWB01382



- **Do not operate this ATV or allow anyone else to operate it without proper instruction. The risk of an accident is greatly increased if the operator does not know how to operate the ATV properly in different situations and on different types of terrain.**
- **Do not operate this ATV at speeds too fast for your skills or the conditions, as this increases your chances of losing control of the ATV and an accident. Always go at a speed that is proper for the terrain, visibility and operating conditions, and your experience.**

Beginning and inexperienced operators should regularly practice the skills and the operating techniques described in this Owner's Manual.

Riding your ATV requires skills acquired through practice over a period of time.

Do not attempt to operate at maximum performance until you are totally familiar with the ATV's handling and performance characteristics. Take

the time to learn the basic techniques well before attempting more difficult maneuvers. Become familiar with this ATV at slow speeds first, even if you are an experienced operator.

Not recommended for children under 16 years of age.

EWB01391



WARNING

A child under 16 should never operate an ATV with engine size greater than 90 cc. Use by children of ATVs that are not recommended for their age can lead to severe injury or death of the child.



This ATV is designed to carry the operator and cargo only – passengers prohibited.

The long seat is to allow the operator to shift position as needed during operation. It is not for carrying passengers. **WARNING! Never carry a passenger. Carrying a passenger on this ATV greatly reduces your ability to balance and control this ATV. You could have an accident, resulting in severe injury or death to you and/or your passenger.** [EWB01402]



Apparel

Always wear the following to reduce risk of injury in an accident:

- Approved motorcycle helmet that fits properly
- Eye protection (goggles, helmet face shield, or protective eyewear)
- Over-the-ankle boots, gloves, long-sleeved shirt or jacket, and long pants

An approved helmet and other personal protective equipment can reduce the severity of injuries in an accident. **WARNING! Operating without an approved motorcycle helmet increases your chances of a severe head injury or death in the event of an accident.** [EWB01412]

Wear eye protection when operating your ATV to reduce the risk of a serious accident or injury. Eye protection, such as a face shield or goggles, may reduce the risk of foreign material getting in your eyes and help prevent loss of vision. **WARNING! Operating without eye protection can result in an accident and increases your chances of a severe injury in the event of an accident.**

[EWB02612]

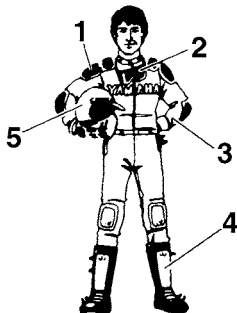

1. Protective clothing
2. Goggles
3. Gloves
4. Boots
5. Helmet

7

Do not operate after or while consuming alcohol or drugs.

The operator's performance capability is reduced by the influence of alcohol or drugs. Consuming alcohol or drugs could seriously affect your judgment, cause you to react more slowly, and affect your balance and perception. **WARNING! Never consume alcohol or drugs before or while driving this ATV. You increase your chance of an accident.** [EWB01422]



Pre-operation checks

Always inspect your ATV each time you use it to make sure the ATV is in safe operating condition. Perform the pre-operation checks listed on page 5-1. Always follow the inspection and maintenance procedures and schedules described in the Owner's Manual. **WARNING! Failure to inspect the ATV before riding it or failure to maintain it properly increases the possibility of an accident and equipment damage.** [EWB01433]

Speed limiter

For riders less experienced with this model, the throttle lever housing is equipped with a speed limiter. The speed limiter keeps the throttle from

fully opening, even when the throttle lever is pushed to the maximum. Turning in the adjusting screw limits the maximum engine power available and decreases the maximum speed of the ATV. Turning in the adjusting screw decreases top speed, and turning it out increases top speed. (See page 4-13.)

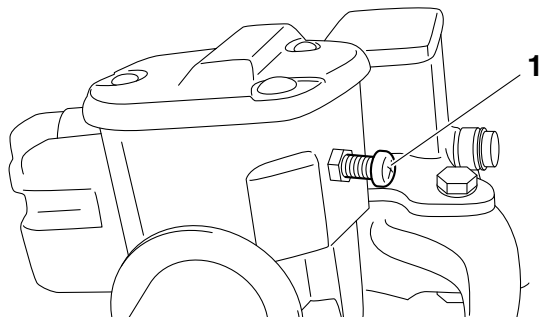

1. Adjusting screw

Loading and accessories

EWB01463



Improper loading or towing can increase the risk of loss of control, an overturn, or other accident. To reduce the risk of an accident:

- **Do not exceed the maximum loading limits for the vehicle (see “MAXIMUM LOADING LIMIT” in this section or vehicle labeling).**
- **Keep weight on racks centered side to side, and as low as possible. Be sure cargo is secured – a loose load could change handling unexpectedly.**
- **Make sure the load does not interfere with your control or ability to see where you are going.**
- **Tie down cargo in the trailer securely. Make sure cargo in the trailer cannot move around. A shifting load can cause an accident.**
- **Reduce speed and allow more room to stop. A heavier vehicle takes longer to stop.**
- **Avoid hills and rough terrain. Choose terrain carefully. Use extreme caution when towing or carrying a load on inclines.**
- **Turn gradually and go slowly.**

Take extra precautions when driving with a load or trailer. Follow these instructions and always use common sense and good judgment when carrying cargo or towing a trailer.

MAXIMUM LOADING LIMIT

ATV loading limit (total weight of cargo, rider, accessories, and tongue):

240.0 kg (530 lb)

Front carrier:

50.0 kg (110 lb)

Rear carrier:

90.0 kg (198 lb)

Front storage compartment:

0.5 kg (1 lb)

Center storage compartment:

4.0 kg (9 lb)

Rear storage compartment:

2.0 kg (4 lb)

Trailer hitch:

Pulling load (total weight of trailer and cargo):

5880 N (600 kgf, 1322 lbf)

Tongue weight (vertical weight on trailer hitch point):

147 N (15 kgf, 33 lbf)

drive slowly (shift into first gear or low drive if available on this model) whenever you are carrying heavier loads or when towing a trailer.

During operation

Always keep your feet on the footboards during operation; otherwise, they may contact the rear wheels. **WARNING! Removing even one hand or foot can reduce your ability to control the ATV or could cause you to lose your balance and fall off of the ATV. If you remove a foot from a footboard, your foot or leg may come into contact with the rear wheels, which could injure you or cause an accident.** [EWB01472]

Drive more slowly than you would without a load. The more weight you carry, the slower you should go. Although conditions vary, it is good practice to

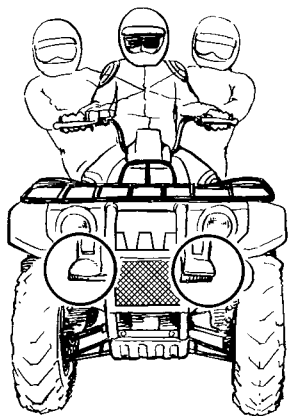

Avoid wheelies and jumping. **WARNING! Attempting wheelies, jumps, and other stunts increases the chance of an accident, including an overturn. Never attempt stunts, such as wheelies or jumps. Don't try to show off.**

[EWB01482]

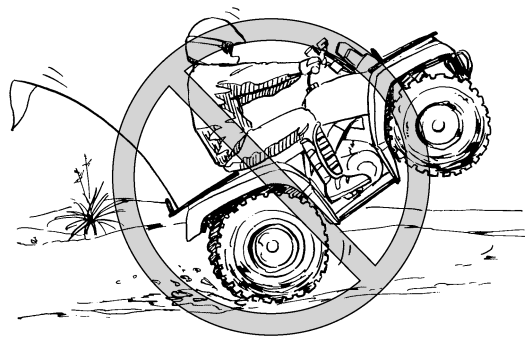

Modifications and accessories

Never modify this ATV through improper installation or use of accessories or other modification. All parts and accessories added to this ATV should be genuine Yamaha or equivalent components designed for use on this ATV and should be installed and used according to instructions. If you have questions, consult an authorized ATV dealer.

WARNING! Operating this ATV with improper modifications may cause changes in handling which in some situations could lead to an accident. [EWB01492]

Exhaust system

EWB01502

⚠ WARNING

- **Dry grass or brush or other combustible material accumulated around the engine area could catch fire. Do not operate, idle, or park the ATV in dry grass or other dry ground cover. Keep the engine area free of dry grass, brush, or other combustible material.**
- **Someone touching the exhaust system during or after operation could be burned. Do not touch the hot exhaust system. Do not park the ATV in a place where others might be likely to touch it.**

7

The muffler and other engine parts become extremely hot during operation and remain hot after the engine has stopped. To reduce the risk of fire during operation or after leaving the ATV, do not let brush, grass and other materials collect under the vehicle, near the muffler or exhaust pipe, or next to other hot parts. Check under the vehicle after operating in areas where combustible materials may have collected. Do not idle or park the vehicle in long dry grass or other dry ground cover.

To prevent burns, avoid touching the exhaust system. Park the ATV in a place where pedestrians or children are not likely to touch it.

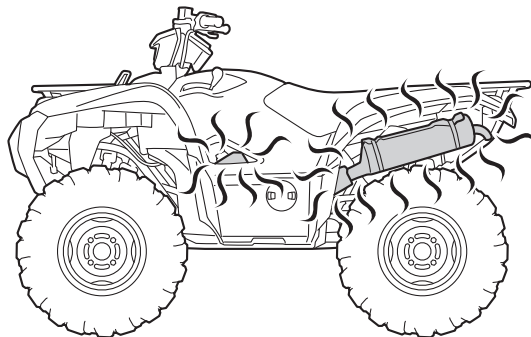

BE CAREFUL WHERE YOU RIDE

This ATV is designed for use on unpaved surfaces only. **WARNING! Paved surfaces may seriously affect handling and control of the ATV, and may cause the ATV to go out of control. Always avoid paved surfaces, including sidewalks, driveways, parking lots and streets.** [EWB01512]

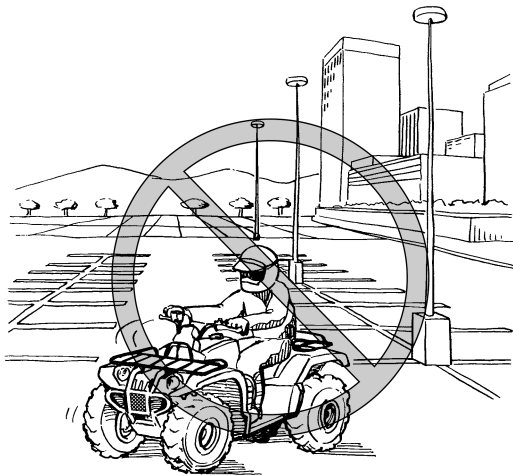

While riding on unpaved public streets or roads may be legal in your area, such operation can increase the risk of collision with other vehicles. Watch carefully for other vehicles. Make sure you

know your country's laws and regulations before you ride on unpaved public streets or roads. Do not ride on any paved public street, road or motorway. **WARNING! Never operate this ATV on any paved street, paved road or motorway. You can collide with another vehicle.** [EWB01522]

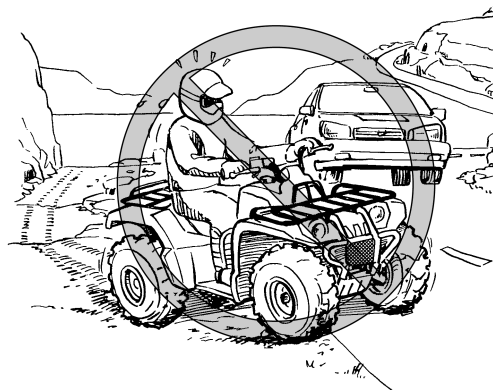

Know the terrain where you ride. Ride cautiously in unfamiliar areas. Stay alert for holes, rocks, or roots in the terrain, and other hidden hazards which may cause the ATV to upset. **WARNING! The ATV could go out of control if you do not have enough time to react to hidden rocks, bumps, or holes. Go slowly and be extra care-**

ful when operating on unfamiliar terrain. Always be alert to changing terrain conditions when operating the ATV. [EWB01532]



Do not operate on rough, slippery, or loose terrain until you have learned and practiced the skills necessary to control the ATV on such terrain. Always be especially cautious on these kinds of terrain. **WARNING! Failure to use extra care when operating on excessively rough, slippery, or loose**

terrain could cause loss of traction or ATV control, which could result in an accident, including an overturn. [EWB01542]



When riding in an area where you might not easily be seen, such as desert terrain, mount a caution flag on the ATV. **DO NOT** use the flag pole bracket as a trailer hitch. **WARNING! You could collide with another vehicle if operating in areas where you cannot easily be seen. Mount a caution flag on the ATV to make you more visible. Watch carefully for other vehicles.** [EWB01552]

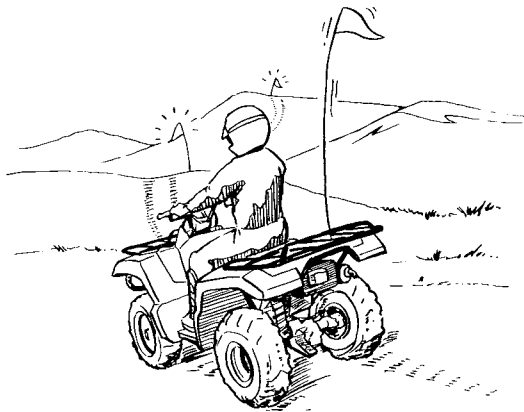

Do not ride in areas posted “no trespassing”.
Do not ride on private property without getting permission.

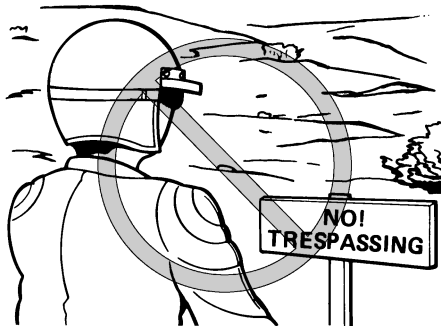

Select a large, flat, unpaved area to become familiar with your ATV. Make sure that this area is free of obstacles and other riders. You should practice control of the throttle, brakes, shifting procedures, and turning techniques in this area before trying more difficult terrain.

Shift to the park position and follow the instruction on page 6-1 to start the engine. Once it has warmed up you are ready to begin riding your ATV. With the engine idling, shift the drive select lever into the low-range position or the high-range position. Apply the throttle slowly and smoothly. The centrifugal clutch will engage and you will start to accelerate. If the throttle is applied too abruptly, the front wheels may lift off the ground, resulting in a loss of directional control. Avoid higher speeds until you are thoroughly familiar with the operation of your ATV.

When slowing down or stopping, release the throttle and apply the brakes smoothly and evenly. Improper use of the brakes can cause the tires to lose traction, reducing control and increasing the possibility of an accident.

NOTICE

Do not shift from low-range to high-range or vice versa without coming to a complete stop. Damage to the engine or drive train may occur.

TURNING YOUR ATV

EWB01772

WARNING

Always follow proper procedures for turning as described in this Owner's Manual. Practice turning at low speeds before attempting to turn at faster speeds. Do not turn at speeds too fast for your skills or the conditions. ATV could go out of control, causing a collision or overturn.

7

To achieve maximum traction on unpaved surfaces, the two rear wheels turn together at the same speed. Therefore, unless the wheel on the inside of the turn is allowed to slip or lose some traction, the ATV will resist turning. A special turning technique must be used to allow the ATV to make turns quickly and easily. It is essential that this skill be learned first at low speed.

As you approach a curve, slow down and begin to turn the handlebars in the desired direction. As you do so, put your weight on the footboard to the outside of the turn (opposite your desired direction) and lean your upper body into the turn. Use the throttle to maintain an even speed through the turn. This maneuver will let the wheel on the inside of the turn slip slightly, allowing the ATV to make the turn properly.

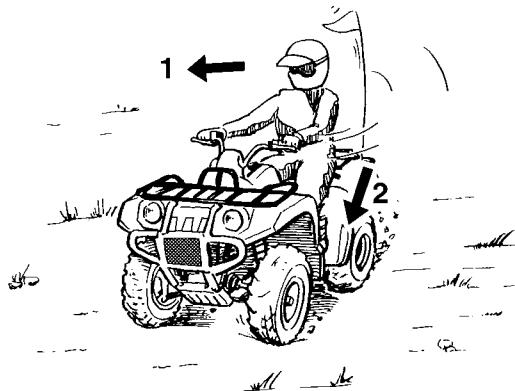

1. Lean towards inside of turn.
2. Support your weight on the outer footboard.

This procedure should be practiced at slow speed many times in a large unpaved area with no obstacles. If an incorrect technique is used, your ATV

may continue to go straight. If the ATV doesn't turn, come to a stop and then practice the procedure again. If the riding surface is slippery or loose, it may help to position more of your weight over the front wheels by moving forward on the seat.

Once you have learned this technique, you should be able to perform it at higher speeds or in tighter curves.

Improper riding procedures such as abrupt throttle changes, excessive braking, incorrect body movements, or too much speed for the sharpness of the turn may cause the ATV to tip. If the ATV begins to tip over to the outside while negotiating a turn, lean more to the inside. It may also be necessary to gradually let off on the throttle and steer to the outside of the turn to avoid tipping over.

Remember: Avoid higher speeds until you are thoroughly familiar with the operation of your ATV.

CLIMBING UPHILL

EWB01672



Climbing hills improperly can cause overturns or loss of control. Use proper riding techniques described in this Owner's Manual.

- **Never operate the ATV on hills too steep for the ATV or for your abilities. The ATV can overturn more easily on extremely steep hills than on level surfaces or small hills.**
- **Always check the terrain carefully before you start up any hill. Never climb hills with excessively slippery or loose surfaces.**
- **Shift your weight forward.**
- **Never open the throttle suddenly. The ATV could flip over backwards.**
- **Never go over the top of any hill at high speed. An obstacle, a sharp drop, or another vehicle or person could be on the other side of the hill.**
- **Never attempt to turn the ATV around on any hill until you have mastered the turning technique as described in the Owner's Manual on level ground. Be very careful when turning on any hill.**
- **Avoid crossing the side of a steep hill if possible. When crossing the side of a hill, shift your weight to the uphill side of the ATV.**

OK

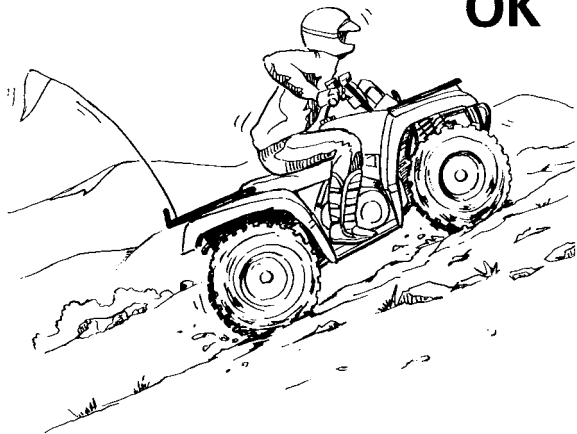

7

OK

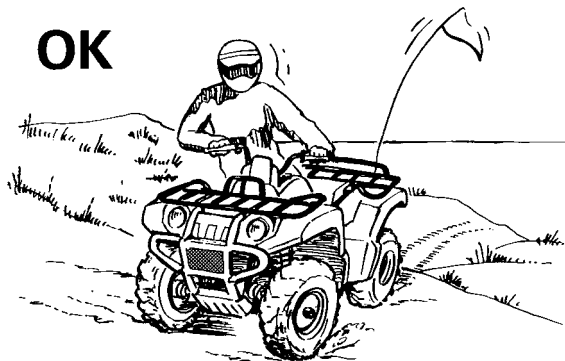

Do not attempt to climb hills until you have mastered basic maneuvers on flat ground. Always check the terrain carefully before attempting any hill. In all cases avoid inclines with slippery or loose surfaces, or obstacles that might cause you to lose control.

To climb a hill, you need traction, momentum, and steady throttle. For more traction and control for climbing steeper and/or rougher slopes, select “4WD” or 4WD-LOCK (“DIFF. LOCK”). Travel fast enough to maintain momentum, but not so fast that you cannot react to changes in the terrain as you climb.

It is important when climbing a hill to make sure that your weight is transferred forward on the ATV. This can be accomplished by leaning forward and, on steeper inclines, standing on the footboards and leaning forward over the handlebars. Whenever possible, ride straight up hills.

Slow down when you reach the crest of the hill if you cannot see clearly what is on the other side – there could be another person, an obstacle, or a sharp drop-off. Use common sense and remember that some hills are too steep for you to climb or descend.

If you are climbing a hill and you find that you have not properly judged your ability to make it to the top, you should turn the ATV around while you still have forward motion (provided you have the room to do so) and go down the hill.

If your ATV has stalled or stopped and you believe you can continue up the hill, restart carefully to make sure you do not lift the front wheels which could cause you to lose control. If you are unable to continue up the hill, dismount the ATV on the uphill side. Physically turn the ATV around and then descend the hill.

If you start to roll backwards, DO NOT apply either brake abruptly. If you are in "2WD", apply only the front brake. When fully stopped, apply the rear brake as well, and then shift to the park position. If you are in "4WD", because all wheels are interconnected by the drive train, applying either brake will brake all wheels, therefore, avoid sudden application of either the front or rear brake as the wheels on the uphill side could come off the ground. The ATV could easily tip over backwards. Apply both the front and rear brakes gradually. When fully stopped, lock shift to the park position and dismount the ATV immediately on the uphill side. Dismount on uphill side or to a side if pointed

straight uphill. Turn the ATV around and remount, following the procedure described in the Owner's Manual. **WARNING! Stalling, rolling backwards or improperly dismounting while climbing a hill could result in ATV overturning. If you cannot control the ATV, dismount immediately on the uphill side.** [EWB01803]

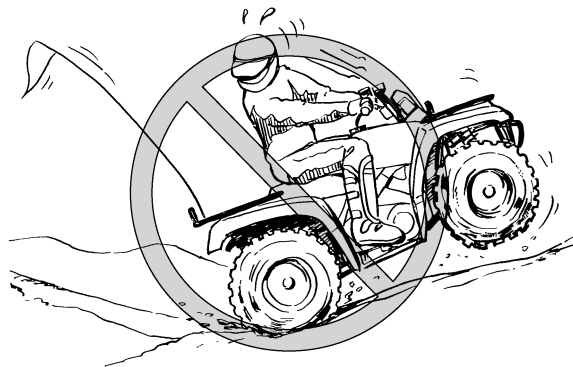

RIDING DOWNHILL

EWB01622



WARNING

Going down a hill improperly could cause overturns or loss of control. Always follow proper procedures for going down hills as described in this Owner's Manual.

- **Always check the terrain carefully before you start down any hill.**
- **Never operate the ATV on hills too steep for the ATV or for your abilities. The ATV can overturn more easily on extremely steep hills than on level surfaces or small hills.**
- **Shift your weight backward and to the up side of the hill.**
- **Never go down a hill at high speed.**
- **Avoid going down a hill at an angle that would cause the ATV to lean sharply to one side. Go straight down the hill where possible.**
- **Improper braking can cause the wheels on the uphill side to come off the ground or cause loss of traction. Apply brakes gradually. If in “2WD”, apply only the rear brake.**

When riding your ATV downhill, shift your weight as far to the rear and uphill side of the ATV as possible. Move back on the seat and sit with your arms straight. Engine compression will do most of the braking for you. For maximum engine compression braking effect, select the low-range position and change to “4WD” before beginning to descend the hill.

Use caution while descending a hill with loose or slippery surfaces. Braking ability and traction may be adversely affected by these surfaces. Improper braking may also cause a loss of traction.

When this ATV is in “4WD”, all wheels (front and rear) are interconnected by the drive train. This means that applying either the front brake or the rear brake will brake all wheels. When descending hills, using either brake lever or the brake pedal will brake the wheels on the downhill side. Avoid sudden application of either the front or rear brake because the wheels on the uphill side could come off the ground. Apply both the front and rear brakes gradually.

Whenever possible, ride your ATV straight downhill. Avoid sharp angles which could allow the ATV to tip or roll over. Carefully choose your path and ride no faster than you will be able to react to obstacles which may appear.

OK



CROSSING A SLOPE

EWB01633

WARNING

Improperly crossing hills or turning on hills could cause loss of control or cause the ATV to overturn.

- Always follow proper procedures as described in the Owner's Manual.
- Avoid hills with excessively slippery or loose surfaces.
- Avoid crossing the side of a steep hill.

- Shift your weight to the uphill side of the ATV.
- Never attempt to turn the ATV around on any hill until you have mastered the turning technique as described in the Owner's Manual on level ground. Be very careful when turning on any hill.

Traversing a sloping surface on your ATV requires you to properly position your weight to maintain proper balance. Be sure that you have learned the basic riding skills on flat ground before attempting to cross a sloping surface. Avoid slopes with slippery surfaces or rough terrain that may upset your balance.

As you travel across a slope, lean your body in the uphill direction. It may be necessary to correct the steering when riding on loose surfaces by pointing the front wheels slightly uphill. When riding on slopes, be sure not to make sharp turns either up or down hill.

If your ATV does begin to tip over, gradually steer in the downhill direction if there are no obstacles in your path. As you regain proper balance, gradually steer again in the direction you wish to travel.

OK



The ATV can be used to cross slow moving, shallow water of up to a maximum of 35 cm (14 in) in depth. Before entering the water, choose your path carefully. Enter where there is no sharp drop off, and avoid rocks or other obstacles which may be slippery or upset the ATV. Drive slowly and carefully.

7

CROSSING THROUGH SHALLOW WATER

EWB01642

WARNING

Operating this vehicle through deep or fast-flowing water can lead to loss of control or an overturn. To reduce your risk of drowning or other injuries, use care when crossing through water. Never operate this ATV water deeper than the depth specified in your Owner's Manual, as tires may float, increasing the risk of an overturn.

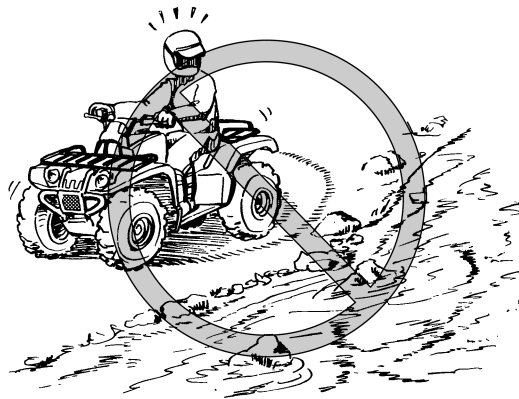

Test your brakes after leaving the water. If necessary, apply them several times to let friction dry out the linings. Do not continue to ride your ATV without verifying that you have regained proper

braking ability. **WARNING! Wet brakes may have reduced stopping ability, which could cause loss of control.** [EWB02622]



After riding your ATV in water, be sure to drain the trapped water by removing the check hose at the bottom of the air filter case. Also, remove the drain plugs from the storage compartments and the V-belt case to drain any water that may have accumulated. **NOTICE: Undrained water can cause damage or improper operation.** [ECB00842]

Wash the ATV in fresh water if it has been operated in salt water or muddy conditions.

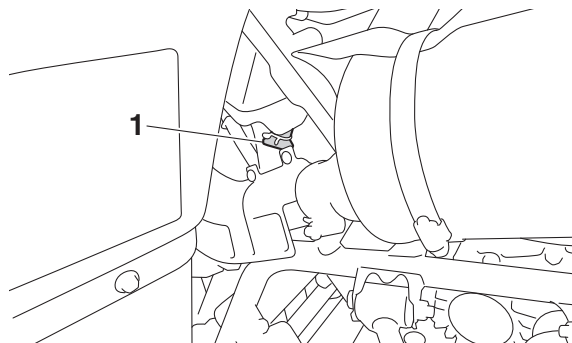

1. Air filter case check hose

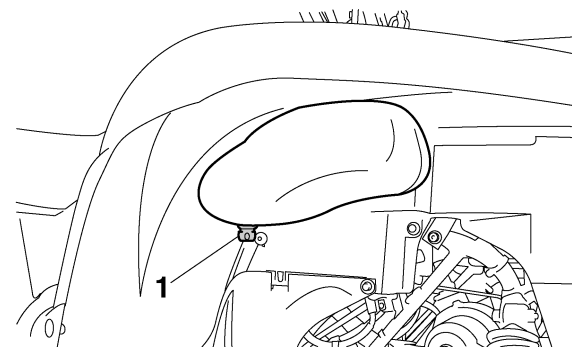

1. Front storage compartment drain plug

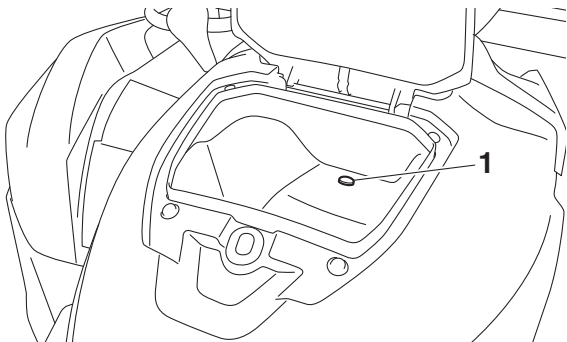

1. Center storage compartment drain plug

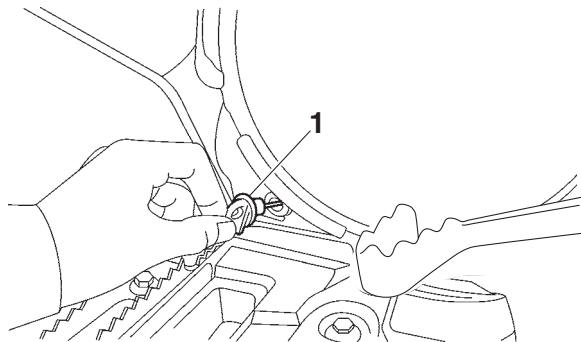

1. V-belt case drain plug

7

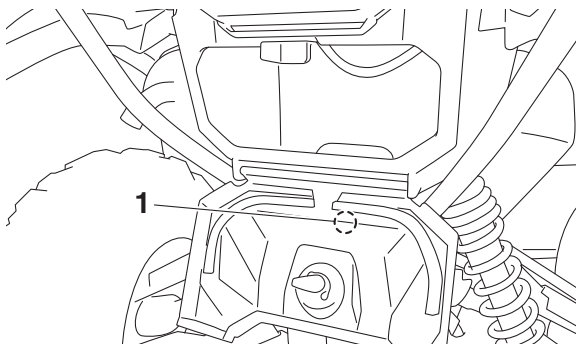

1. Rear storage compartment drain plug

RIDING OVER ROUGH TERRAIN

EWB01652

! WARNING

Riding improperly over obstacles could cause loss of control or a collision. Before operating in a new area, check for obstacles. Never attempt to ride over large obstacles, such as large rocks or fallen trees. When you go over obstacles, always follow proper procedures as described in the Owner's Manual.

Riding over rough terrain should be done with caution. Look out for obstacles which could cause damage to the ATV or could lead to an upset or

accident. Be sure to keep your feet firmly mounted on the footboards at all times. Avoid jumping the ATV as loss of control and damage to the ATV may result.

SLIDING AND SKIDDING

EWB01663

WARNING

Skidding or sliding improperly may cause you to lose control of this ATV. You may also regain traction unexpectedly, which may cause the ATV to overturn.

- Learn to safely control skidding or sliding by practicing at low speeds and on level, smooth terrain.
- On extremely slippery surfaces, such as ice, go slowly and be very cautious in order to reduce the chance of skidding or sliding out of control.

Care should be used when riding on loose or slippery surfaces since the ATV may slide. If unexpected and uncorrected, sliding could lead to an accident.

To reduce the tendency for the front wheels to slide in loose or slippery conditions, positioning your weight over the front wheels will sometimes help.

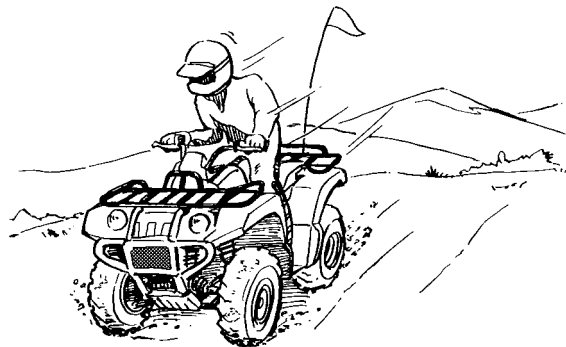

If the rear wheels of your ATV start to slide sideways, control can usually be regained (if there is room to do so) by steering in the direction of the slide. Applying the brakes or accelerating is not recommended until you have corrected the slide.

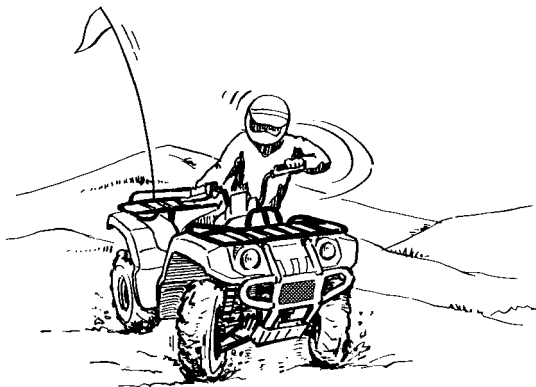

7

With practice, over a period of time, skill at controlled sliding can be developed. The terrain should be chosen carefully before attempting such maneuvers, since both stability and control are reduced. Bear in mind that sliding maneuvers should always be avoided on extremely slippery surfaces such as ice, since all control may be lost.

WHAT TO DO IF...

This section is designed to be a reference guide only. Be sure to read each section on riding techniques completely.

WHAT TO DO...

- If your ATV doesn't turn when you want it to:
Bring the ATV to a stop and practice the turning maneuvers again. Be sure you are putting your weight on the footboard to the outside of the turn. Position your weight over the front wheels for better control. (See page 7-13.)
- If your ATV begins to tip while turning:
Lean more into the turn to regain balance. If necessary, gradually let off the throttle and/or steer to the outside of the turn. (See page 7-13.)
- If your ATV starts to slide sideways:
Steer in the direction of the slide if you have the room. Applying the brakes or accelerating is not recommended until you have corrected the slide. (See page 7-22.)
- If your ATV can't make it up a hill you are trying to climb:
Turn the ATV around if you still have forward speed. If not, stop, dismount on the uphill side of the ATV and physically turn the ATV around. If the ATV starts to slip backwards, **DO NOT USE THE REAR BRAKE IF THE ATV IS IN "2WD"** – the ATV may tip over on top of you. Dismount the ATV on the uphill side. (See page 7-14.)

- If your ATV is traversing a sloping surface:
Be sure to ride with your weight positioned towards the uphill side of the ATV to maintain proper balance. If the ATV starts to tip, steer down the hill (if there are no obstacles in your way) to regain balance. If you discover that the ATV is going to tip over, dismount on the uphill side. (See page 7-18.)
- If your ATV encounters shallow water:
Ride slowly and carefully through slow moving water, watching for obstacles. Be sure to let water drain from the ATV and **CHECK YOUR BRAKES FOR PROPER OPERATION** when you come out of the water. Do not continue to ride your ATV until you have regained adequate braking ability. (See page 7-19.)

PERIODIC MAINTENANCE AND ADJUSTMENT

Periodic inspection, adjustment, and lubrication will keep your vehicle in the safest and most efficient condition possible. Safety is an obligation of the vehicle owner/operator. The most important points of vehicle inspection, adjustment, and lubrication are explained on the following pages.

WARNING

Failure to properly maintain the vehicle or performing maintenance activities incorrectly may increase your risk of injury or death during service or while using the vehicle. If you are not familiar with vehicle service, have a Yamaha dealer perform the service.

WARNING

Turn off the engine when performing maintenance unless otherwise specified.

- **A running engine has moving parts that can catch on body parts or clothing and electrical parts that can cause shocks or fires.**

- **Running the engine while servicing can lead to eye injury, burns, fire, or carbon monoxide poisoning - possibly leading to death. See page 2-6 for more information about carbon monoxide.**

WARNING

Brake discs, calipers, drums, and linings can become very hot during use. To avoid possible burns, let brake components cool before touching them.

The intervals given in the periodic maintenance charts should be considered as a general guide under normal riding conditions. However, DEPENDING ON THE WEATHER, TERRAIN, GEOGRAPHICAL LOCATION, AND INDIVIDUAL USE, THE MAINTENANCE INTERVALS MAY NEED TO BE SHORTENED.

Owner's manual and tool kit

Be sure to always keep the owner's manual, the owner's tool kit and the low-pressure tire gauge with the vehicle. Make sure to protect the owner's manual by putting it in the plastic bag, then by placing the bag in the document pouch.

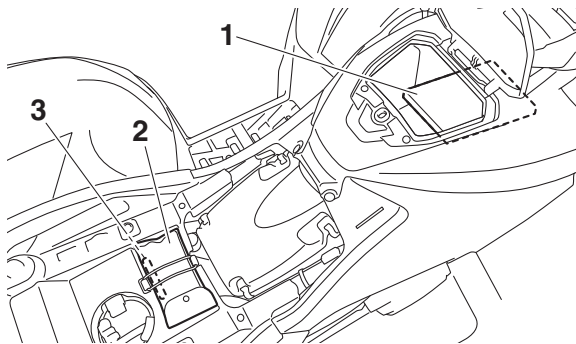

1. Owner's manual
2. Owner's tool kit
3. Low-pressure tire gauge

The service information included in this manual and the tools provided in the owner's tool kit are intended to assist you in the performance of preventive maintenance and minor repairs. However,

additional tools such as a torque wrench may be necessary to perform certain maintenance work correctly.

TIP

If you do not have the tools or experience required for a particular job, have a Yamaha dealer perform it for you.

Periodic maintenance chart for the emission control system

TIP

- For ATVs not equipped with an odometer or an hour meter, follow the month maintenance intervals.
- For ATVs equipped with an odometer or an hour meter, follow the km (mi) or hours maintenance intervals. However, keep in mind that if the ATV isn't used for a long period of time, the month maintenance intervals should still be followed.
- Items marked with an asterisk should be performed by a Yamaha dealer as they require special tools, data and technical skills.

NO.	ITEM	CHECK OR MAINTENANCE JOB	Whichever comes first ⇒	INITIAL			EVERY		
				month	1	3	6	6	12
				km (mi)	320 (200)	1300 (800)	2500 (1600)	2500 (1600)	5000 (3200)
hours	20	80	160	160	320				
1	* Fuel line	• Check fuel hoses for cracks or other damage, and replace if necessary.				√	√	√	
2	Spark plug	• Check condition and clean, regap, or replace if necessary.		√	√	√	√	√	
3	* Valves	• Check valve clearance and adjust if necessary.		√		√	√	√	
4	* Crankcase breather system	• Check breather hose for cracks or other damage, and replace if necessary.				√	√	√	
5	* Exhaust system	• Check for leakage and replace gasket(s) if necessary. • Check for looseness and tighten all screw clamps and joints if necessary.				√	√	√	

NO.	ITEM	CHECK OR MAINTENANCE JOB	Whichever comes first ⇒	INITIAL			EVERY		
				month	1	3	6	6	12
				km (mi)	320 (200)	1300 (800)	2500 (1600)	2500 (1600)	5000 (3200)
				hours	20	80	160	160	320
6	Spark arrester	• Clean.			√	√	√		
7	* Air induction system	• Check the air cut-off valve, reed valve, and hose for damage. • Replace any damaged parts if necessary.		√	√	√	√		

General maintenance and lubrication chart

TIP

- For ATVs not equipped with an odometer or an hour meter, follow the month maintenance intervals.
- For ATVs equipped with an odometer or an hour meter, follow the km (mi) or hours maintenance intervals. However, keep in mind that if the ATV isn't used for a long period of time, the month maintenance intervals should still be followed.
- Items marked with an asterisk should be performed by a Yamaha dealer as they require special tools, data and technical skills.

NO.	ITEM	CHECK OR MAINTENANCE JOB	Whichever comes first ⇒	INITIAL			EVERY		
				month	1	3	6	6	12
				km (mi)	320 (200)	1300 (800)	2500 (1600)	2500 (1600)	5000 (3200)
				hours	20	80	160	160	320
1	Air filter element	<ul style="list-style-type: none"> • Clean and replace if necessary. 		Every 20–40 hours (more often in wet or dusty areas)					
2	* Front brake	<ul style="list-style-type: none"> • Check operation and correct if necessary. • Check fluid level and ATV for fluid leakage, and correct if necessary. 		√	√	√	√	√	
		<ul style="list-style-type: none"> • Replace brake pads. 		Whenever worn to the limit					

NO.	ITEM	CHECK OR MAINTENANCE JOB	Whichever comes first ⇒	INITIAL			EVERY		
				month	1	3	6	6	12
				km (mi)	320 (200)	1300 (800)	2500 (1600)	2500 (1600)	5000 (3200)
hours	20	80	160	160	320				
3	*	Rear brake	<ul style="list-style-type: none"> • Check operation and correct if necessary. • Check brake pedal free play and adjust if necessary. • Check fluid level and ATV for fluid leakage, and correct if necessary. 		√	√	√	√	√
				<ul style="list-style-type: none"> • Replace brake pads. 	Whenever worn to the limit				
4	*	Brake hoses	<ul style="list-style-type: none"> • Check for cracks or other damage, and replace if necessary. • Replace. 			√	√	√	√
					Every 4 years				
5	*	Brake fluid	<ul style="list-style-type: none"> • Change. 	Every 2 years					
6	*	Wheels	<ul style="list-style-type: none"> • Check runout and for damage, and replace if necessary. 	√		√	√	√	
7	*	Tires	<ul style="list-style-type: none"> • Check tread depth and for damage, and replace if necessary. • Check air pressure and balance, and correct if necessary. 	√		√	√	√	
8	*	Wheel hub bearings	<ul style="list-style-type: none"> • Check for looseness or damage, and replace if necessary. 	√		√	√	√	
9	*	V-belt	<ul style="list-style-type: none"> • Check for wear, cracks or other damage, and replace if necessary. 	√		√	√	√	
10	*	Chassis fasteners	<ul style="list-style-type: none"> • Make sure that all nuts, bolts, and screws are properly tightened. 	√	√	√	√	√	

NO.	ITEM	CHECK OR MAINTENANCE JOB	Whichever comes first ⇒	INITIAL			EVERY		
				month	1	3	6	6	12
				km (mi)	320 (200)	1300 (800)	2500 (1600)	2500 (1600)	5000 (3200)
				hours	20	80	160	160	320
11	* Shock absorber assemblies	<ul style="list-style-type: none"> • Check operation and correct if necessary. • Check for oil leakage and replace if necessary. 			√	√	√		
12	* Stabilizer bushes	<ul style="list-style-type: none"> • Check for cracks or other damage, and replace if necessary. 			√	√	√		
13	* Rear knuckle pivots	<ul style="list-style-type: none"> • Lubricate with lithium-soap-based grease. 			√	√	√		
14	* Steering shaft	<ul style="list-style-type: none"> • Lubricate with lithium-soap-based grease. 			√	√	√		
15	* Steering system	<ul style="list-style-type: none"> • Check operation and repair or replace if damaged. • Check toe-in and adjust if necessary. 	√	√	√	√	√		
16	* Engine mount	<ul style="list-style-type: none"> • Check for cracks or other damage, and replace if necessary. 			√	√	√		
17	* Axle boots	<ul style="list-style-type: none"> • Check for cracks or other damage, and replace if necessary. 	√	√	√	√	√		
18	Engine oil	<ul style="list-style-type: none"> • Change. • Check ATV for oil leakage, and correct if necessary. 	√		√	√	√		
19	Engine oil filter cartridge	<ul style="list-style-type: none"> • Replace. 	√		√		√		
20	Differential gear oil	<ul style="list-style-type: none"> • Change. • Check ATV for oil leakage, and correct if necessary. 	√				√		

NO.	ITEM	CHECK OR MAINTENANCE JOB	Whichever comes first ⇒	INITIAL			EVERY		
				month	1	3	6	6	12
				km (mi)	320 (200)	1300 (800)	2500 (1600)	2500 (1600)	5000 (3200)
hours	20	80	160	160	320				
21	Final gear oil	<ul style="list-style-type: none"> Change. Check ATV for oil leakage, and correct if necessary. 		√				√	
22	Cooling system	<ul style="list-style-type: none"> Check coolant level and ATV for coolant leakage, and correct if necessary. 		√	√	√	√	√	
		<ul style="list-style-type: none"> Replace coolant. 	Every 2 years						
23	* Moving parts and cables	<ul style="list-style-type: none"> Lubricate. 			√	√	√	√	
24	* Drive select lever safety system cable	<ul style="list-style-type: none"> Check operation and adjust or replace if necessary. 				√	√	√	
25	* Throttle lever	<ul style="list-style-type: none"> Check operation. Check throttle lever free play, and adjust if necessary. Lubricate cable and lever housing. 		√	√	√	√	√	
26	* Front and rear brake switches	<ul style="list-style-type: none"> Check operation and correct if necessary. 		√	√	√	√	√	
27	* Lights and switches	<ul style="list-style-type: none"> Check operation and correct if necessary. Adjust headlight beams. 		√	√	√	√	√	

TIP _____

- Some maintenance items need more frequent service if you are riding in unusually wet, dusty, sandy or muddy areas, or at full-throttle.
 - Hydraulic brake service
 - Regularly check and, if necessary, correct the brake fluid level.
 - Every two years replace the internal components of the brake master cylinders and calipers, and change the brake fluid.
 - Replace the brake hoses every four years and if cracked or damaged.
-

Removing and installing panels

The panels shown need to be removed to perform some of the maintenance jobs described in this chapter. Refer to this section each time a panel needs to be removed and installed.

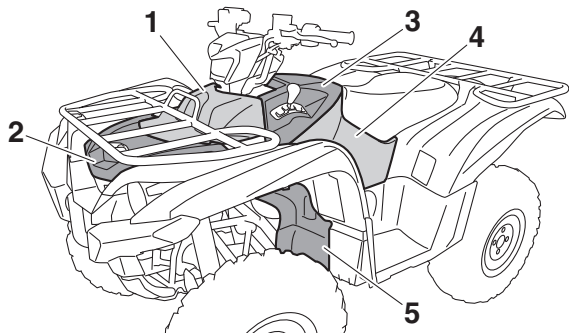

1. Panel A
2. Panel B
3. Panel C
4. Panel D
5. Panel F

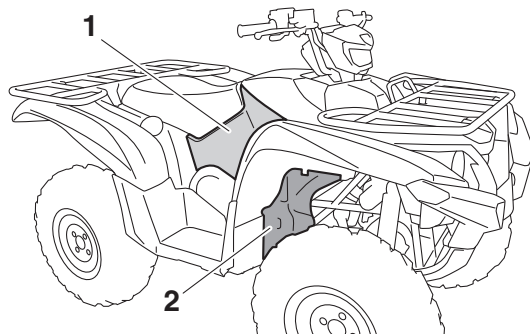

1. Panel E
2. Panel G

EBU34720

Panel A

To remove the panel

Pull upward on the areas shown.

Panel B

To remove the panel

1. Remove panel A.
2. Remove the front carrier by removing the bolts.

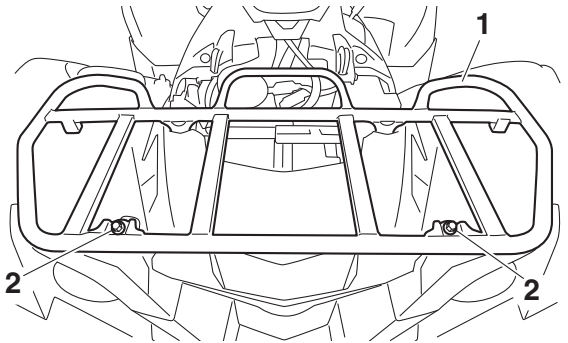

1. Front carrier
2. Carrier bolt (upper)

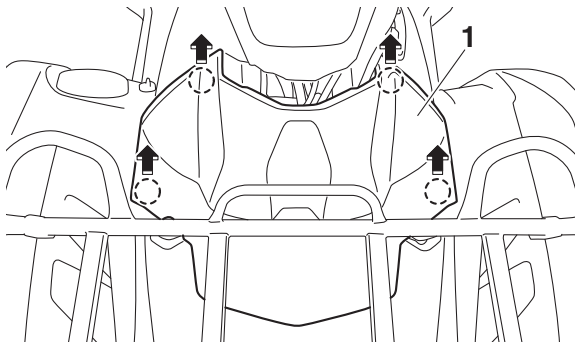

1. Panel A

To install the panel

Place the panel in the original position.

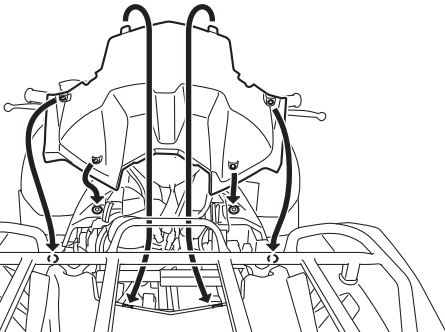

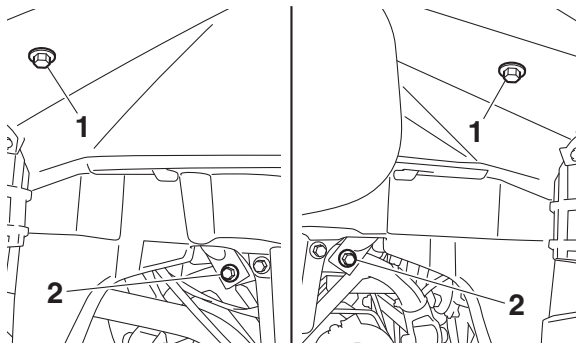

1. Carrier bolt (under the fenders)

2. Carrier bolt (lower)

3. Remove the quick fasteners, pull panel B forward to release the projections, and then pull the panel upward to remove it.

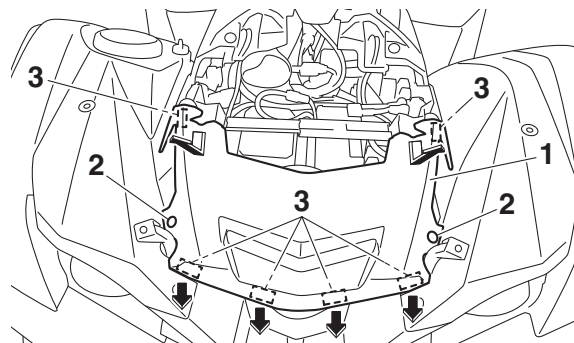

1. Panel B

2. Quick fastener

3. Projection

To install the panel

1. Place the panel in the original position, and then install the quick fasteners.

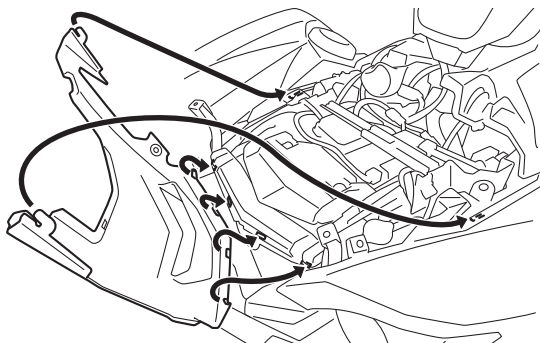

2. Install the front carrier by installing the bolts and tightening them to the specified torques.

Tightening torques:

Carrier bolt (upper):

34 Nm (3.4 m·kgf, 25 ft·lbf)

Carrier bolt (lower):

34 Nm (3.4 m·kgf, 25 ft·lbf)

Carrier bolt (under the fenders):

7 Nm (0.7 m·kgf, 5.1 ft·lbf)

3. Install panel A.

Panel C

To remove the panel

1. Remove the seat. (See page 4-17.)
2. Remove panel A.
3. Remove the hoses from panel C.

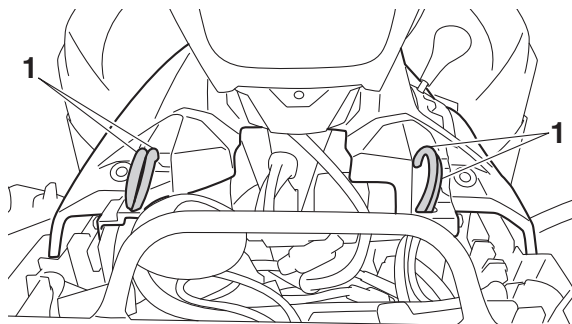

1. Hose

4. Remove the quick fasteners and bolts.

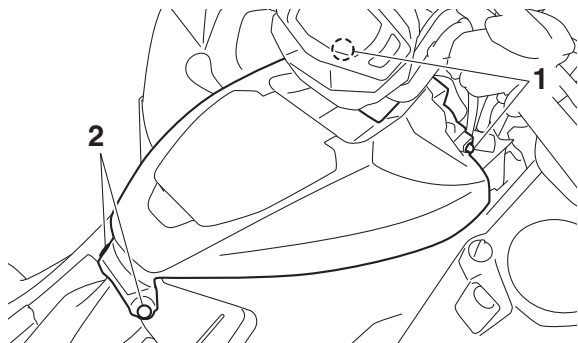

1. Bolt
2. Quick fastener

5. Remove the screws under the storage compartment lid, and then pull the panel upward to remove it.

TIP

To ease removal of panel C, shift the drive select lever into the reverse position.

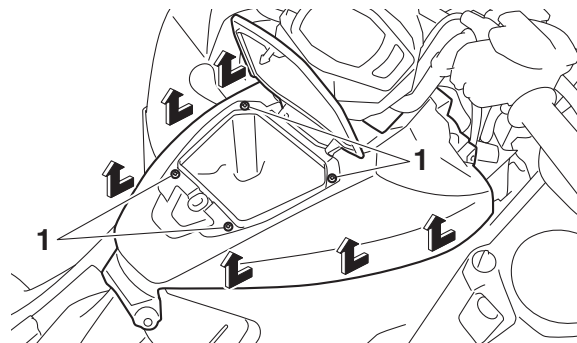

1. Screw

To install the panel

1. Place the panel in the original position.

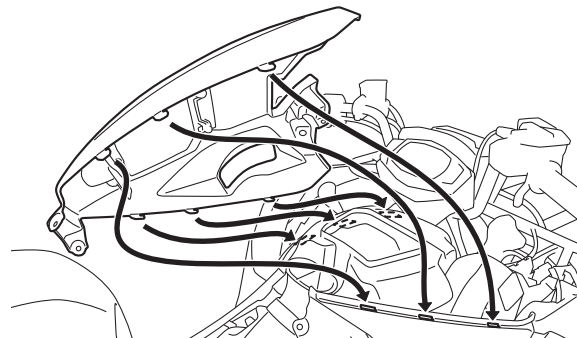

2. Install the screws, quick fasteners, bolts, and hoses.

TIP

Make sure that the hoses are properly connected and routed, and are not pinched.

3. Install panel A.
4. Install the seat.

Panels D and E

To remove a panel

1. Remove panels A and C.
2. Remove the bolt, and then pull the panel upward to remove it.

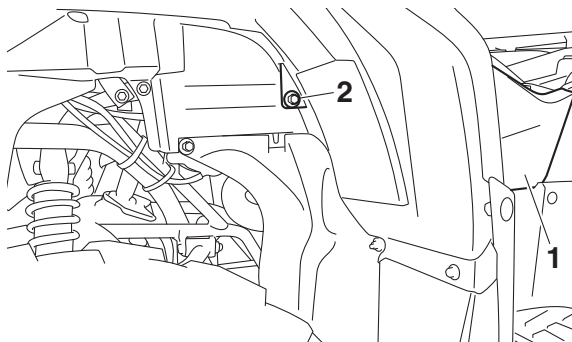

1. Panel D
2. Bolt

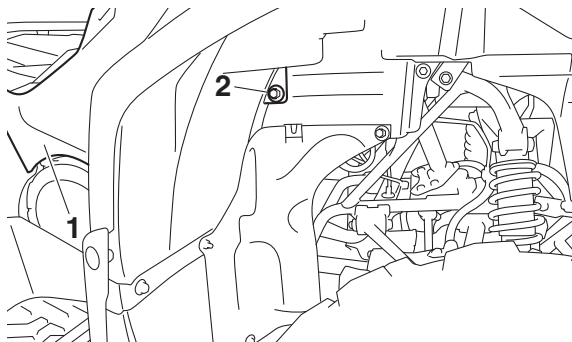

1. Panel E
2. Bolt

To install a panel

1. Place the panel in the original position, and then install the bolt.

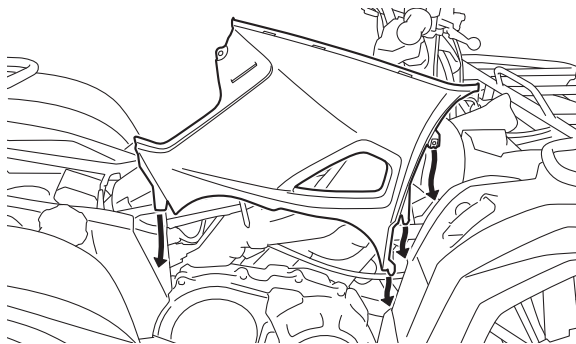
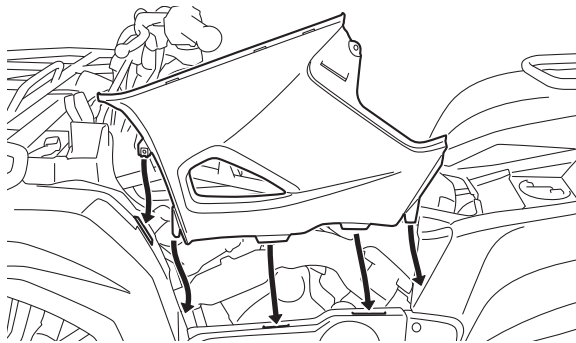

2. Install panels A and C.

Panels F and G

To remove a panel

1. Remove the panel bolts, footboard bolt, and footboard nut.

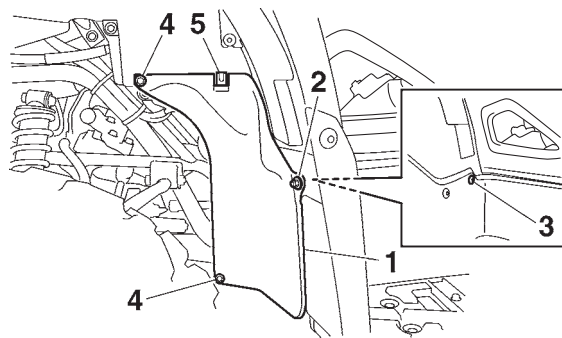

1. Panel F
2. Footboard nut
3. Footboard bolt
4. Panel bolt
5. Projection

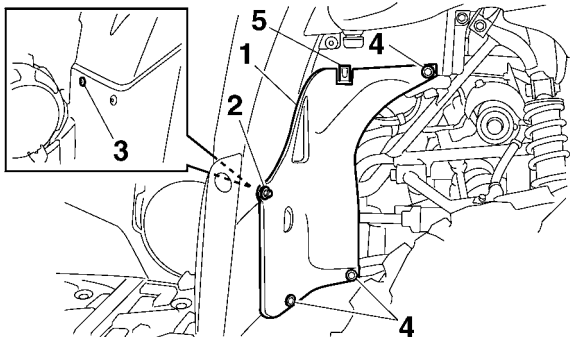

1. Panel G
2. Footboard nut
3. Footboard bolt
4. Panel bolt
5. Projection

8

2. Pull the panel downward while pushing the projection.

To install a panel

1. Place the panel in the original position.

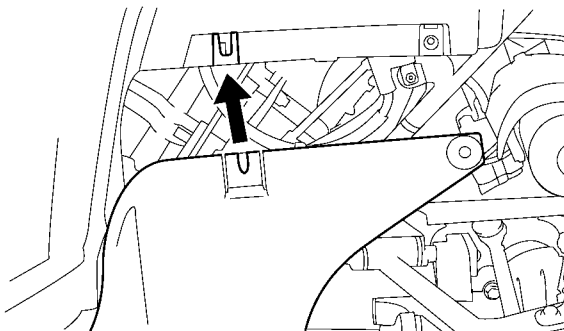
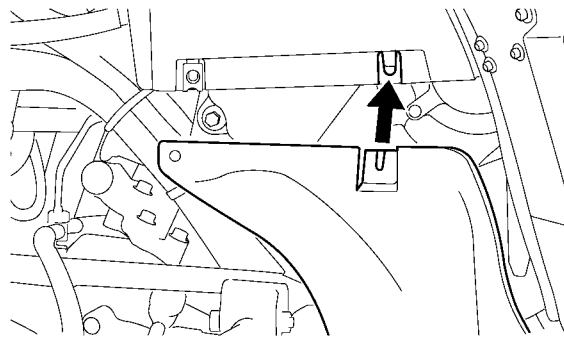

2. Install the bolts and nut, and then tighten them to the specified torques.

Tightening torques:

Panel bolt:

4.0 Nm (0.40 m·kgf, 2.9 ft·lbf)

Footboard nut:

4.0 Nm (0.40 m·kgf, 2.9 ft·lbf)

EBU34190

Checking the spark plug

The spark plug is an important engine component, which is easy to check. Since heat and deposits will cause any spark plug to slowly erode, the spark plug should be removed and checked in accordance with the periodic maintenance and lubrication chart. In addition, the condition of the spark plug can reveal the condition of the engine.

To remove the spark plug

1. Remove panels A and C. (See page 8-10.)
2. Remove the storage compartment by removing the bolt.

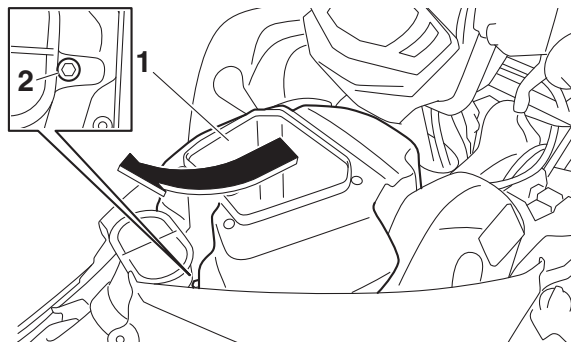

1. Storage compartment
2. Bolt

3. Remove the spark plug cap.

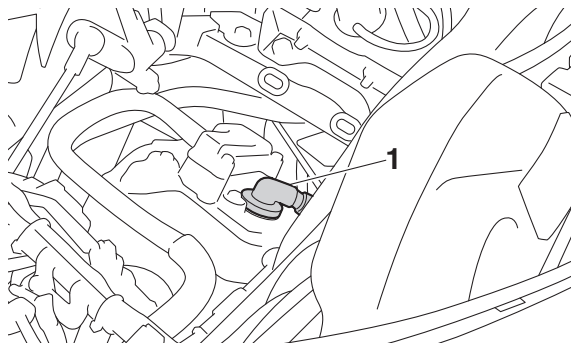

1. Spark plug cap

4. Remove the spark plug as shown, with the spark plug wrench included in the owner's tool kit.

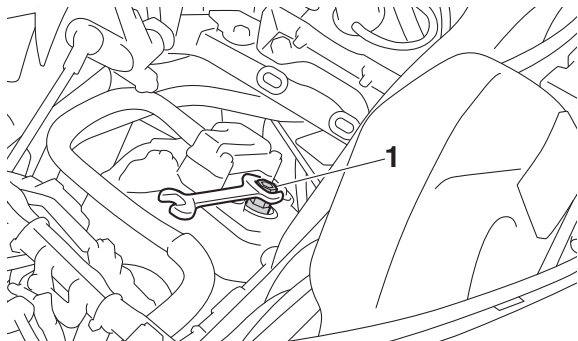

1. Spark plug wrench

8

To check the spark plug

1. Check that the porcelain insulator around the center electrode of the spark plug is a medium-to-light tan (the ideal color when the vehicle is ridden normally).

TIP

If the spark plug shows a distinctly different color, the engine could be operating improperly. Do not attempt to diagnose such problems yourself. Instead, have a Yamaha dealer check the vehicle.

2. Check the spark plug for electrode erosion and excessive carbon or other deposits, and replace it if necessary.

Specified spark plug:
NGK/CPR7EA-9

3. Measure the spark plug gap with a wire thickness gauge and, if necessary, adjust the gap to specification.

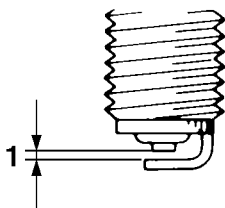

1. Spark plug gap

Spark plug gap:
0.8–0.9 mm (0.031–0.035 in)

To install the spark plug

1. Clean the surface of the spark plug gasket and its mating surface, and then wipe off any grime from the spark plug threads.
2. Install the spark plug with the spark plug wrench, and then tighten it to the specified torque.

Tightening torque:
Spark plug:
11 Nm (1.1 m·kgf, 8.0 ft·lbf)

TIP

If a torque wrench is not available when installing the spark plug, a good estimate of the correct torque is 1/4–1/2 turn past finger tight. However, the spark plug should be tightened to the specified torque as soon as possible.

3. Install the spark plug cap.
4. Install the storage compartment as shown, and then install the bolt.



5. Install the panels.

Engine oil and oil filter cartridge

The engine oil level should be checked before each ride. In addition, the oil must be changed and the oil filter cartridge replaced at the intervals specified in the periodic maintenance and lubrication chart.

To check the engine oil level

1. Place the ATV on a level surface.
2. Check the engine oil level on a cold engine.

TIP

If the engine was started before checking the oil level, be sure to warm up the engine sufficiently, and then wait at least 10 minutes until the oil settles for an accurate reading.

3. Remove the access cover by turning it counterclockwise.

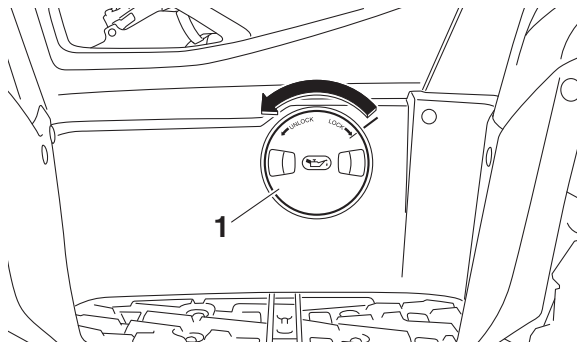

1. Access cover

4. Remove the engine oil dipstick, and then wipe it off with a clean rag.

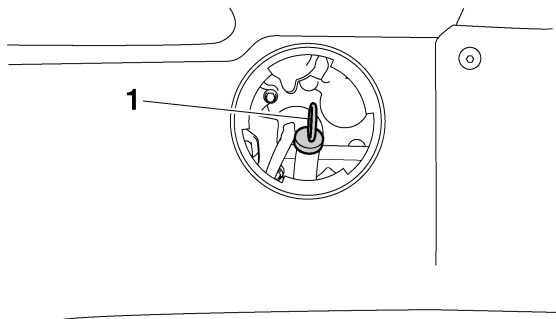

1. Engine oil dipstick

5. Insert the dipstick completely into the oil filler hole, and then remove it again to check the oil level.

TIP

The engine oil should be between the minimum and maximum level marks.

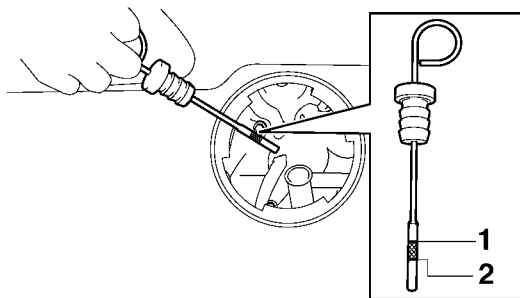

1. Maximum level mark
2. Minimum level mark

6. If the engine oil is at or below the minimum level mark, add sufficient oil of the recommended type to raise it to the correct level.

NOTICE: Be sure the engine oil is at the correct level, otherwise engine damage may result. [ECB00852]

7. Insert the dipstick completely into the oil filler hole.
8. Install the access cover by turning it clockwise.

To change the engine oil (with or without oil filter cartridge replacement)

1. Place the ATV on a level surface.
2. Start the engine, warm it up for several minutes, and then turn it off.
3. Remove the access cover by turning it counterclockwise.
4. Place an oil pan under the engine to collect the used oil.
5. Remove the dipstick, and then remove the engine oil drain bolt and its gasket to drain the oil from the crankcase.

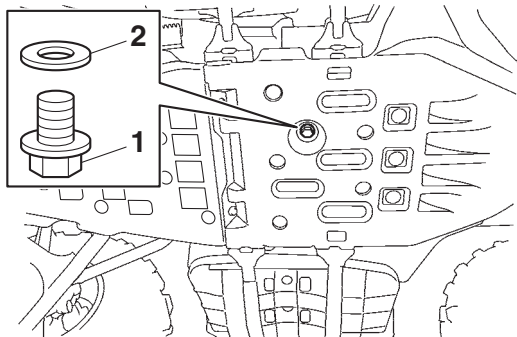

1. Engine oil drain bolt
2. Gasket

TIP _____
8 Skip steps 6–10 if the oil filter cartridge is not being replaced.

6. Remove panel F. (See page 8-10.)
7. Remove the oil filter cartridge with an oil filter wrench.

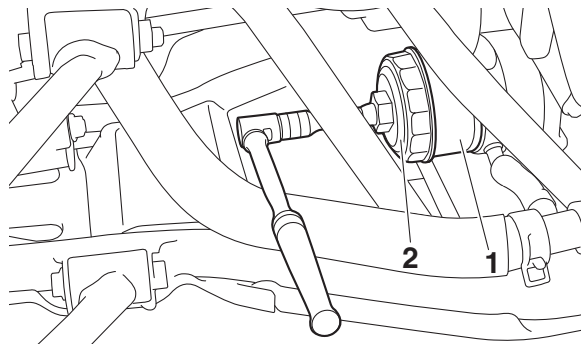

1. Oil filter cartridge
2. Oil filter wrench

TIP _____
An oil filter wrench is available at a nearby Yamaha dealer.

8. Apply a thin coat of engine oil to the O-ring of the new oil filter cartridge.

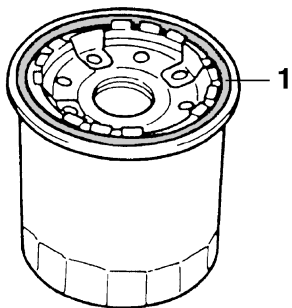

1. O-ring

TIP

Make sure that the O-ring is properly seated.

9. Install the new oil filter cartridge with an oil filter wrench, and then tighten it to the specified torque with a torque wrench.

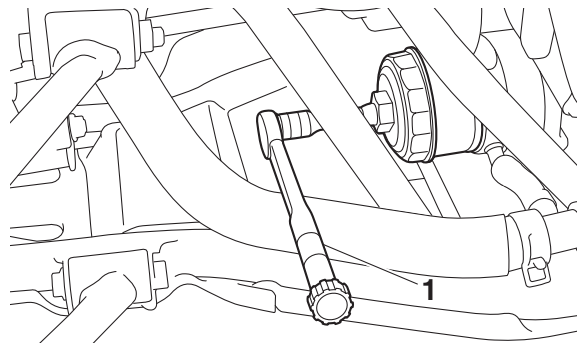

1. Torque wrench

Tightening torque:

Oil filter cartridge:

15 Nm (1.5 m·kgf, 11 ft·lbf)

10. Install panel F.

11. Install the engine oil drain bolt and its new gasket, and then tighten the bolt to the specified torque.

Tightening torque:

Engine oil drain bolt:

22 Nm (2.2 m·kgf, 16 ft·lbf)

12. Refill with the specified amount of the recommended engine oil, and then insert the dipstick completely into the oil filler hole.

Recommended oil:

See page 10-1.

Oil quantity:

Without oil filter cartridge replacement:

2.00 L (2.11 US qt, 1.76 Imp.qt)

With oil filter cartridge replacement:

2.10 L (2.22 US qt, 1.85 Imp.qt)

TIP

Be sure to wipe off spilled oil on any parts after the engine and exhaust system have cooled down.

ECB00301

NOTICE

- **In order to prevent clutch slippage (since the engine oil also lubricates the clutch), do not mix any chemical additives. Do not use oils with a diesel specification of “CD” or oils of a higher quality than specified. In addition, do not use oils labeled “ENERGY CONSERVING II” or higher.**

- **Make sure that no foreign material enters the crankcase.**

13. Start the engine, and then let it idle for several minutes while checking it for oil leakage. If oil is leaking, immediately turn the engine off and check for the cause.
14. Turn the engine off, wait at least ten minutes, and then check the oil level and correct it if necessary.
15. Install the access cover by turning it clockwise.

EBU27307

Final gear oil

The final gear case must be checked for oil leakage before each ride. If any leakage is found, have a Yamaha dealer check and repair the ATV. In addition, the final gear oil level must be checked and the oil changed as follows at the intervals specified in the periodic maintenance and lubrication chart.

To check the final gear oil level

1. Place the ATV on a level surface.

2. Remove the final gear oil level check bolt and its gasket, and then check the oil level in the final gear case. The oil level should be at the brim of the check hole.

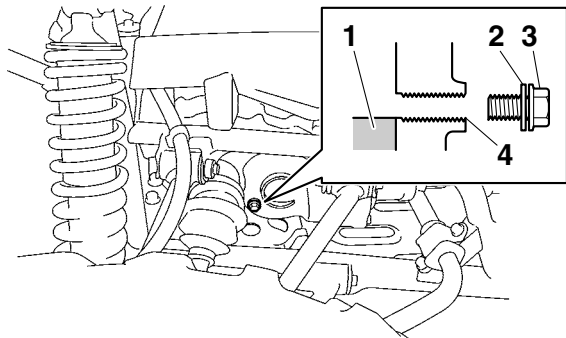

1. Final gear oil
2. Gasket
3. Final gear oil level check bolt
4. Correct oil level

3. If the oil is below the brim of the check hole, remove the final gear oil filler bolt and its gasket, and then add sufficient oil of the recommended type to raise it to the correct level.

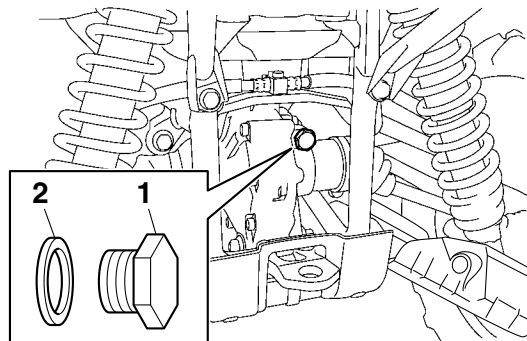

1. Final gear oil filler bolt
2. Gasket

4. Check the gaskets for damage, and replace them if necessary.
5. Install the oil level check bolt, the oil filler bolt and their gasket, and then tighten the bolts to the specified torques.

Tightening torques:

Final gear oil level check bolt:

10 Nm (1.0 m·kgf, 7.2 ft·lbf)

Final gear oil filler bolt:

23 Nm (2.3 m·kgf, 17 ft·lbf)

To change the final gear oil

1. Place the ATV on a level surface.
2. Place an oil pan under the final gear case to collect the used oil.
3. Remove the final gear oil filler bolt, the final gear oil level check bolt, the final gear oil drain bolt and their gasket to drain the oil from the final gear case.

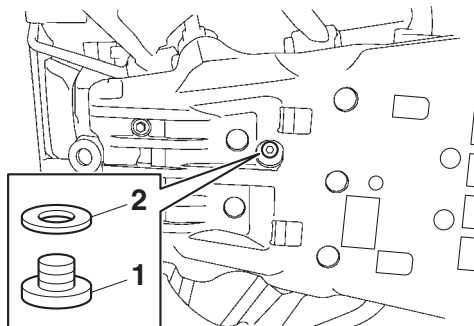

1. Final gear oil drain bolt
2. Gasket

4. Install the drain bolt and its new gasket, and then tighten the bolt to the specified torque.

Tightening torque:

Final gear oil drain bolt:

23 Nm (2.3 m-kgf, 17 ft-lbf)

5. Refill with the recommended final gear oil to the brim of the check hole as shown.
NOTICE: Be sure no foreign material enters the final gear case. [ECB00422]

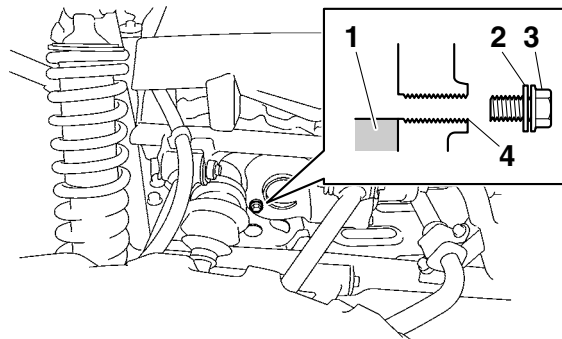

1. Final gear oil
2. Gasket
3. Final gear oil level check bolt
4. Correct oil level

Recommended final gear oil:

See page 10-1.

6. Check the oil level check bolt gasket and the oil filler bolt gasket for damage, and replace them if necessary.
7. Install the oil level check bolt, the oil filler bolt and their gasket, and then tighten the bolts to the specified torques.

Tightening torques:

Final gear oil level check bolt:

10 Nm (1.0 m·kgf, 7.2 ft·lbf)

Final gear oil filler bolt:

23 Nm (2.3 m·kgf, 17 ft·lbf)

8. Check the final gear case for oil leakage. If oil is leaking, check for the cause.

EBU23427

Differential gear oil

The differential gear case must be checked for oil leakage before each ride. If any leakage is found, have a Yamaha dealer check and repair the ATV. In addition, the differential gear oil level must be checked and the oil changed as follows at the intervals specified in the periodic maintenance and lubrication chart.

To check the differential gear oil level

1. Place the ATV on a level surface.
2. Remove the differential gear oil filler bolt and its gasket, and then check the oil level in the differential gear case. The oil level should be at the brim of the filler hole.

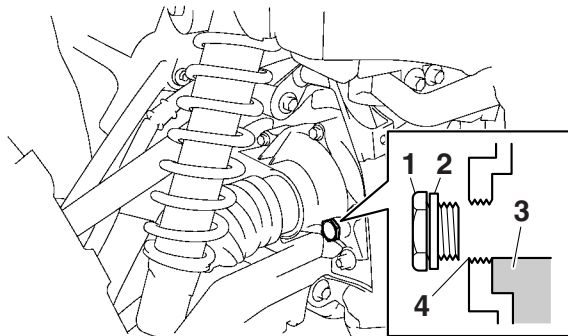

1. Differential gear oil filler bolt
 2. Gasket
 3. Differential gear oil
 4. Correct oil level
3. If the oil is below the brim of the filler hole, add sufficient oil of the recommended type to raise it to the correct level.
 4. Check the gasket for damage, and replace it if necessary.

5. Install the oil filler bolt and its gasket, and then tighten the bolt to the specified torque.

Tightening torque:

Differential gear oil filler bolt:
23 Nm (2.3 m·kgf, 17 ft·lbf)

4. Install the drain bolt and its new gasket, and then tighten the bolt to the specified torque.

Tightening torque:

Differential gear oil drain bolt:
9.8 Nm (0.98 m·kgf, 7.1 ft·lbf)

To change the differential gear oil

1. Place the ATV on a level surface.
2. Place an oil pan under the differential gear case to collect the used oil.
3. Remove the differential gear oil filler bolt, the differential gear oil drain bolt and their gasket to drain the oil from the differential gear case.

5. Refill with the recommended differential gear oil to the brim of the filler hole as shown.

NOTICE: Be sure no foreign material enters the differential gear case. [ECB00412]

8

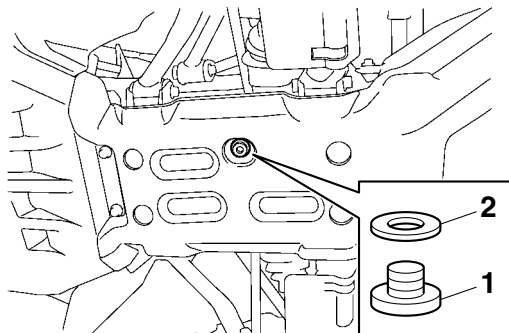

1. Differential gear oil drain bolt
2. Gasket

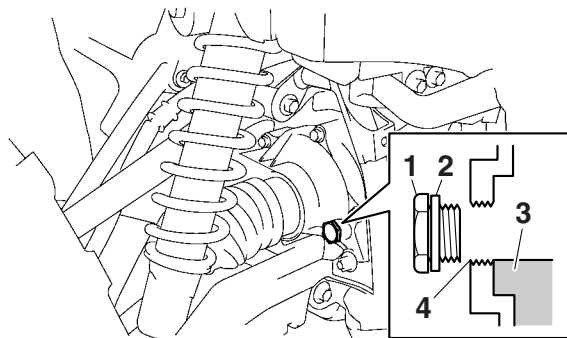

1. Differential gear oil filler bolt
2. Gasket
3. Differential gear oil
4. Correct oil level

Recommended differential gear oil:
See page 10-1.

6. Check the oil filler bolt gasket for damage, and replace it if necessary.
7. Install the oil filler bolt and its gasket, and then tighten the bolt to the specified torque.

Tightening torque:
Differential gear oil filler bolt:
23 Nm (2.3 m·kgf, 17 ft·lbf)

8. Check the differential gear case for oil leakage. If oil is leaking, check for the cause.

EBU23471

Coolant

The coolant level should be checked before each ride. In addition, the coolant must be changed at the intervals specified in the periodic maintenance and lubrication chart.

EBU34201

To check the coolant level

1. Park the ATV on a level surface.

TIP _____
The coolant level must be checked on a cold engine since the level varies with engine temperature.

2. Check the coolant level in the coolant reservoir.

TIP _____
The coolant should be between the minimum and maximum level marks.

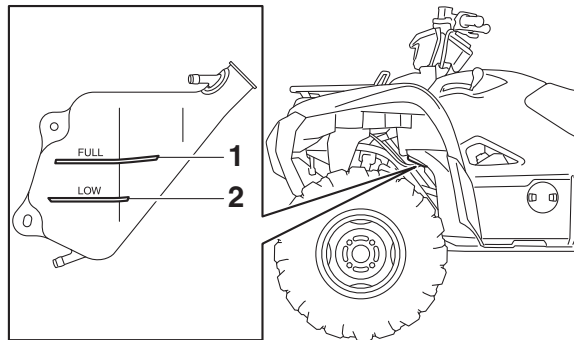

1. Maximum level mark
2. Minimum level mark

3. If the coolant is at or below the minimum level mark, remove panels A and C to access the coolant reservoir. (See page 8-10.)
4. Remove the coolant reservoir cap, add coolant or distilled water to the maximum level mark, install the reservoir cap, and then install the panels. **NOTICE: If coolant is not available, use distilled water or soft tap water instead. Do not use hard water or salt water since they are harmful to the engine. If water has been used instead of coolant, replace it with coolant as soon as possible, otherwise the cooling system will not be protected against frost and corrosion. If water has been added to the coolant, have a Yamaha dealer check the antifreeze content of the coolant as soon as possible, otherwise the effectiveness of the coolant will be reduced.** [ECB01012]

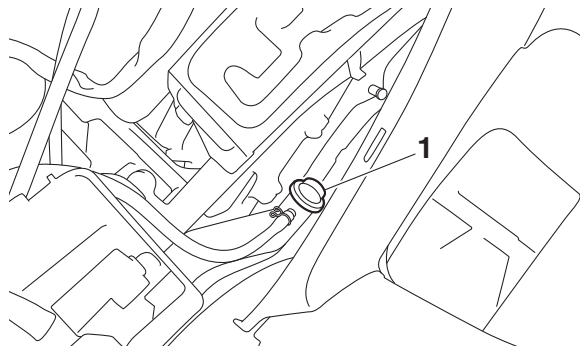

1. Coolant reservoir cap

Coolant reservoir capacity (up to the maximum level mark):

0.25 L (0.26 US qt, 0.22 Imp.qt)

TIP

- The radiator fan is automatically switched on or off according to the coolant temperature in the radiator.
- If the engine overheats, see page 8-66 for further instructions.

To change the coolant**⚠ WARNING**

Wait for the engine and radiator to cool before removing the radiator cap. You could be burned by hot fluid and steam blown out under pressure. Always place a thick rag over the cap when opening. Allow any remaining pressure to escape before completely removing the cap.

1. Park the ATV on a level surface.
2. Remove panels A, B, C, and D. (See page 8-10.)
3. Remove the footboard by removing the bolts and nuts.

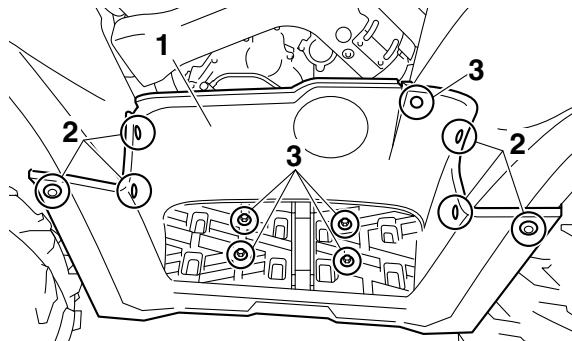

1. Footboard
2. Bolt and nut
3. Bolt
4. Remove the radiator cap.

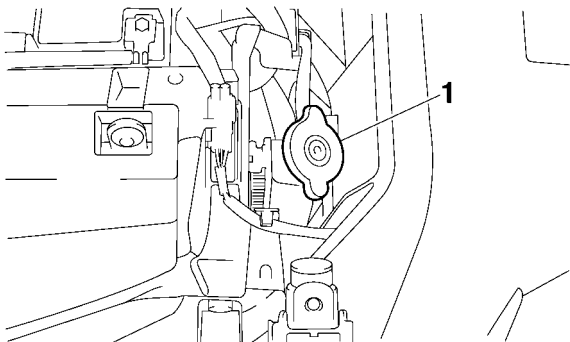

1. Radiator cap

5. Place a container under the engine, and then remove the coolant drain bolt and its gasket. (Use a trough or a similar object as shown to prevent coolant from spilling on the engine guard.)

8

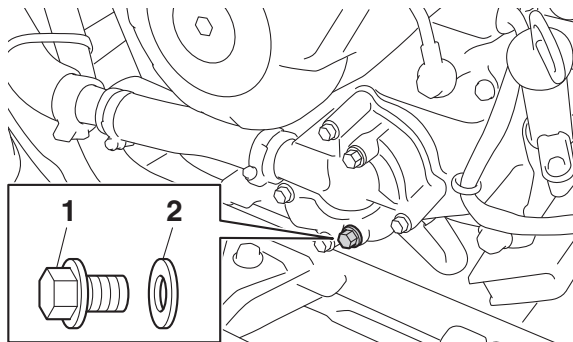

1. Coolant drain bolt

2. Gasket

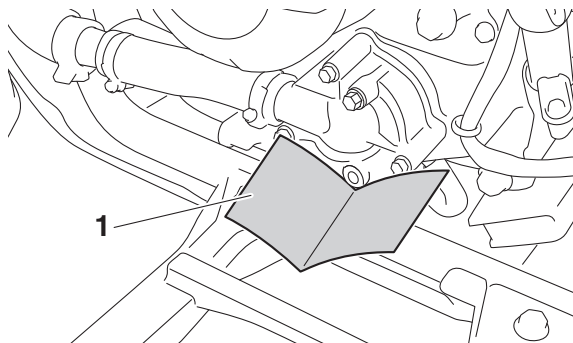

1. Trough

6. Place a container under the coolant reservoir to collect the used coolant.
7. Remove the coolant reservoir cap.
8. Disconnect the coolant reservoir hose on the coolant reservoir side, and then drain the coolant from the coolant reservoir.

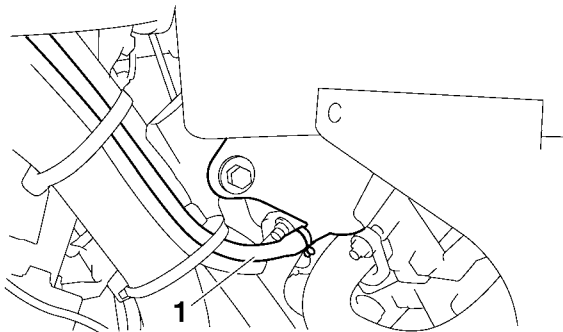

1. Coolant reservoir hose

9. After draining the coolant, thoroughly flush the cooling system with clean tap water.
10. Install the coolant drain bolt and its new gasket, and then tighten the bolt to the specified torque.

Tightening torque:

Coolant drain bolt:

8 Nm (0.8 m·kgf, 5.8 ft·lbf)

11. Connect the coolant reservoir hose.
12. Pour the recommended coolant into the radiator until it is full.
13. Pour the recommended coolant into the reservoir to the maximum level mark, and then install the reservoir cap. **NOTICE: Mix anti-freeze with distilled water only. However, if distilled water is not available, soft water may be used for refilling. Do not use hard water or salt water since they are harmful to the engine.** [ECB00992]

Antifreeze/water mixture ratio:

1:1

Recommended antifreeze:

High-quality ethylene glycol antifreeze containing corrosion inhibitors for aluminum engines

Coolant quantity:

Radiator (including all routes):

1.76 L (1.86 US qt, 1.55 Imp.qt)

Coolant reservoir (up to the maximum level mark):

0.25 L (0.26 US qt, 0.22 Imp.qt)

14. Loosen the water pump air bleed bolt, without removing it, to allow all of the air to escape from the air bleed bolt hole.

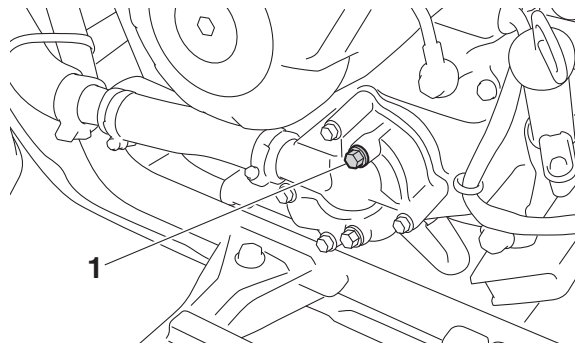

1. Water pump air bleed bolt

15. When coolant begins to flow out of the bolt hole, tighten the water pump air bleed bolt to the specified torque.

Tightening torque:

Water pump air bleed bolt:

8 Nm (0.8 m·kgf, 5.8 ft·lbf)

16. Remove panel E. (See page 8-10.)
17. Loosen the cylinder head air bleed bolt, without removing it, to allow all of the air to escape from the air bleed bolt hole.

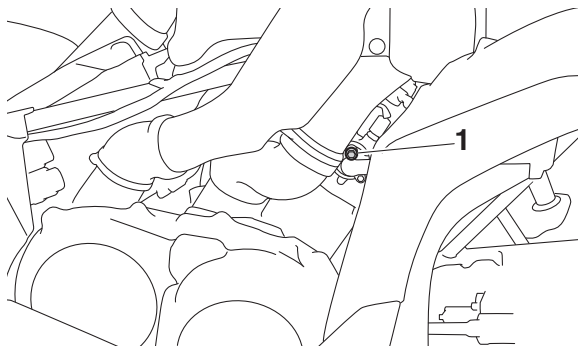

1. Cylinder head air bleed bolt

18. When coolant begins to flow out of the bolt hole, tighten the cylinder head air bleed bolt to the specified torque.

Tightening torque:

Cylinder head air bleed bolt:
10 Nm (1.0 m·kgf, 7.2 ft·lbf)

19. Start the engine and let it idle for ten minutes.
20. Rev the engine five times.
21. Pour additional coolant into the radiator until it is full.

22. Stop the engine and allow it to cool. If the coolant level has dropped after the engine has cooled, add sufficient coolant until it reaches the top of the radiator, and then install the radiator cap.
23. Start the engine, and then check for coolant leakage.

TIP

If any leakage is found, have a Yamaha dealer check the cooling system.

24. Install the footboard by installing the bolts and nuts, and then tighten them to the specified torques.

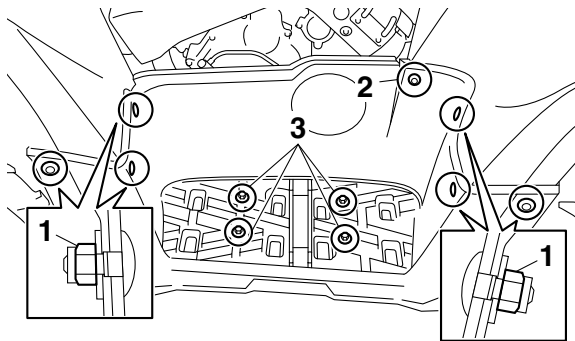

1. Footboard nut
2. Footboard bolt A
3. Footboard bolt B

8

TIP _____
Tighten footboard bolts B in the order shown.

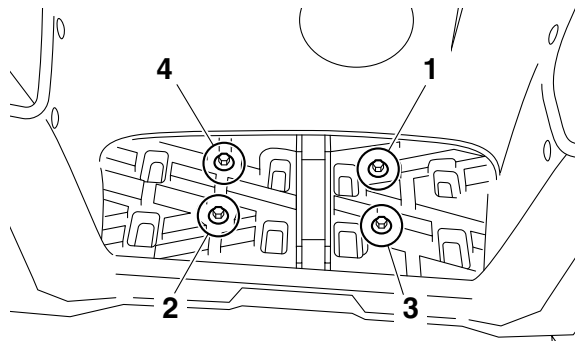

Tightening torques:

Footboard nut:

4.0 Nm (0.40 m·kgf, 2.9 ft·lbf)

Footboard bolt A:

4.0 Nm (0.40 m·kgf, 2.9 ft·lbf)

Footboard bolt B:

8 Nm (0.8 m·kgf, 5.8 ft·lbf)

25. Install the panels.

Cleaning the air filter element

The air filter element should be cleaned at the intervals specified in the periodic maintenance and lubrication chart. Clean or, if necessary, replace the air filter element more frequently if you are riding in unusually wet or dusty areas.

TIP

There is a check hose at the bottom of the air filter case. If dust or water collects in this hose, empty the hose and clean the air filter element and air filter case.

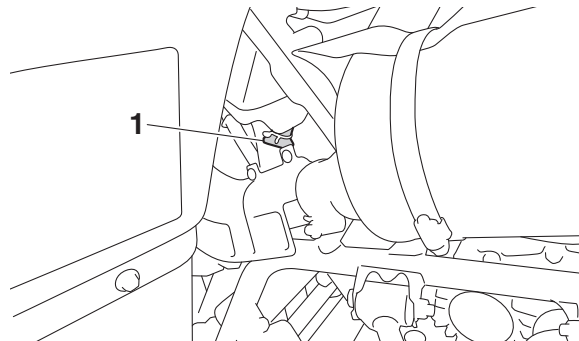

1. Air filter case check hose

1. Place the ATV on a level surface.

2. Remove the seat. (See page 4-17.)
3. Remove the air filter case cover by unhooking the air filter case cover holders.

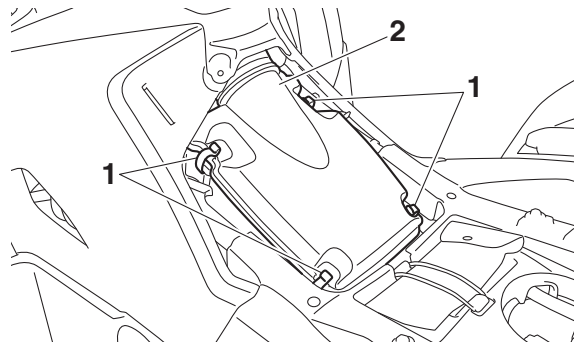

1. Air filter case cover holder
2. Air filter case cover

4. Pull the air filter element out of the air filter case.

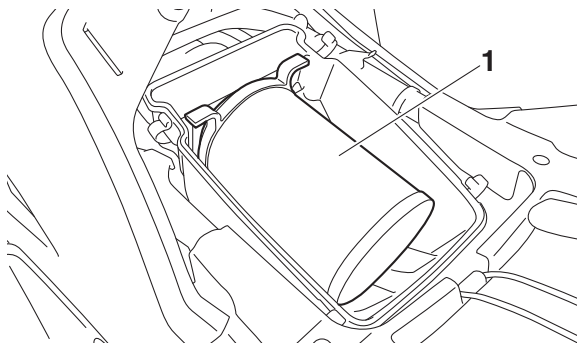

1. Air filter element

5. Pull off the air filter element lock plate, and then remove the sponge material from the air filter element frame.

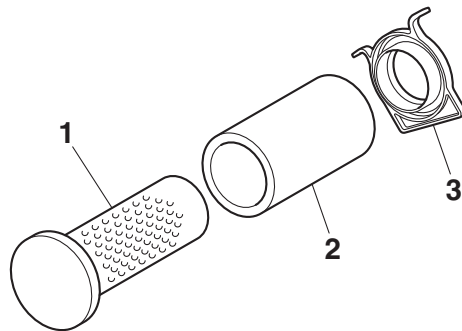

1. Air filter element frame
2. Sponge material
3. Air filter element lock plate

6. Wash the sponge material gently but thoroughly in solvent. **WARNING! Always use parts cleaning solvent to clean the sponge material. Never use low-flash-point solvents or gasoline to clean the sponge material because the engine could catch fire or explode.** [EWB01942]
7. Squeeze the excess solvent out of the sponge material and let it dry. **NOTICE: Do not twist the sponge material when squeezing it.** [ECB00442]

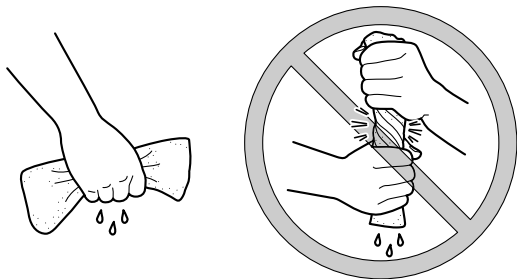

8. Check the sponge material and replace it if damaged.
9. Apply Yamaha foam air filter oil or other quality foam air filter oil to the sponge material.

TIP

The sponge material should be wet but not dripping.

10. Pull the sponge material over the air filter element frame, and then install the lock plate.
11. Insert the air filter element into the air filter case, and then install the air filter case cover by hooking the holders onto the air filter case.
NOTICE: Make sure that the air filter element is properly seated in the air filter

case. Never operate the engine with the air filter element removed. Doing so would allow unfiltered air to enter the engine, causing rapid engine wear and possible engine damage. Additionally, the fuel injection system would be affected resulting in poor engine performance and possible overheating. [ECB00763]

12. Install the seat.

TIP

The air filter element should be cleaned every 20–40 hours. It should be cleaned and lubricated more often if the ATV is operated in extremely dusty areas. Each time the air filter element maintenance is performed, check the air inlet of the air filter case for obstructions. Check the air filter case rubber joint to the throttle body and the rubber joint manifold fittings for an air-tight seal. Tighten all fittings securely to avoid the possibility of unfiltered air entering the engine.

EBU28904

Cleaning the spark arrester

Be sure the exhaust pipe and muffler are cool before cleaning the spark arrester.

1. Remove the tailpipe bolts.

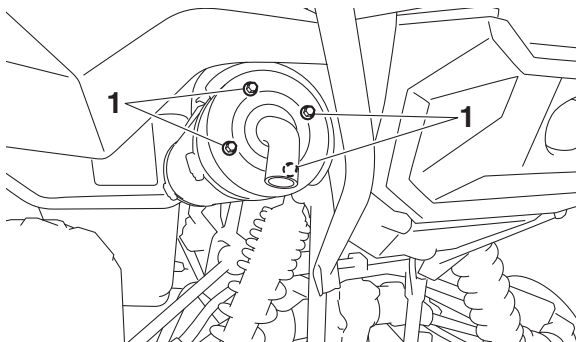

1. Tailpipe bolt

2. Remove the tailpipe by pulling it out of the muffler, and then remove the gasket.
3. Tap the tailpipe lightly, and then use a wire brush to remove any carbon deposits from the spark arrester portion of the tailpipe and inside of the tailpipe housing.

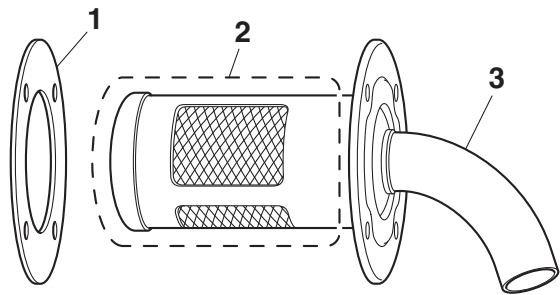

1. Gasket
2. Spark arrester
3. Tailpipe

4. Check the gasket for damage, and replace it if necessary.
5. Make sure the gasket is properly positioned, then insert the tailpipe into the muffler and align the bolt holes.
6. Install the bolts and tighten them to the specified torque.

Tightening torque:

Tailpipe bolt:

10 Nm (1.0 m·kgf, 7.2 ft·lbf)

⚠ WARNING

Do not start the engine when cleaning the spark arrester, otherwise it could cause injury to the eyes, burns, carbon monoxide poisoning, possibly leading to death, and start a fire. Always let the exhaust system cool prior to touching exhaust components.

V-belt case drain plug

After riding in water deep enough to allow it to enter the V-belt case, remove the V-belt case drain plug to drain the water from the case.

TIP

If water drains from the V-belt case after removing the plug, have a Yamaha dealer check the ATV as the water may affect other engine parts.

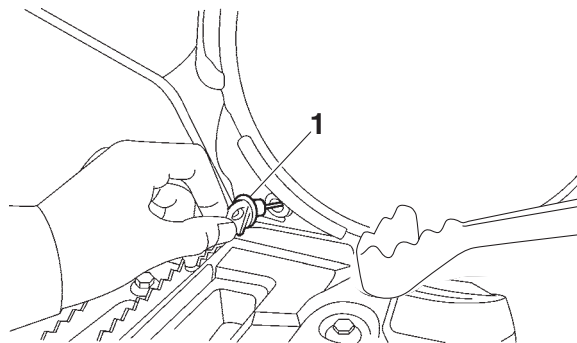

1. V-belt case drain plug

Adjusting the throttle lever free play

The throttle lever free play should be checked and, if necessary, adjusted at the intervals specified in the periodic maintenance and lubrication chart. The throttle lever free play should measure 3.0–5.0 mm (0.12–0.20 in) as shown. Periodically check the throttle lever free play and, if necessary, adjust it as follows.

1. Slide the rubber cover back.
2. Loosen the locknut.

- To increase the throttle lever free play, turn the throttle lever free play adjusting bolt in direction (a). To decrease the throttle lever free play, turn the adjusting bolt in direction (b).

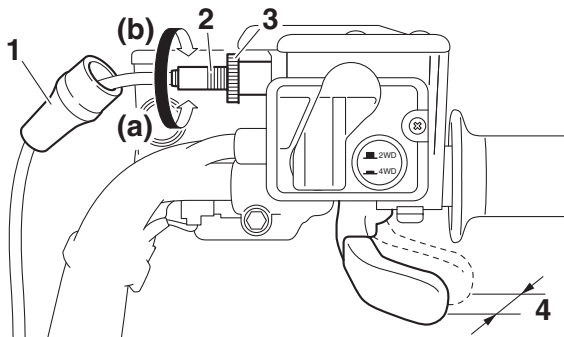

8

- Rubber cover
 - Throttle lever free play adjusting bolt
 - Locknut
 - Throttle lever free play
- Tighten the locknut.
 - Slide the rubber cover to its original position.

EBU24061

Valve clearance

The valve clearance changes with use, resulting in improper air-fuel mixture and/or engine noise. To prevent this from occurring, the valve clearance

must be adjusted by a Yamaha dealer at the intervals specified in the periodic maintenance and lubrication chart.

EBU24072

Adjusting the drive select lever safety system cable

The drive select lever safety system cable stretches with use, which can result in improper function. Therefore, the safety system cable should be checked and adjusted by a Yamaha dealer at the intervals specified in the periodic maintenance and lubrication chart.

EBU29602

Brakes

Replacement of brake components requires professional knowledge. Brake service should be performed by a Yamaha dealer.

EWB02572



Operating with improperly serviced or adjusted brakes could lead to a loss in braking ability and an accident.

Checking the front and rear brake pads

The front and rear brake pads must be checked for wear at the intervals specified in the periodic maintenance and lubrication chart. Each brake pad is provided with a wear indicator groove, which allows you to check the brake pad wear without having to disassemble the brake. If a brake pad has worn to the point that the wear indicator groove has almost disappeared, have a Yamaha dealer replace the brake pads as a set.

TIP

The wheels need to be removed to check the brake pads. (See page 8-62.)

Front brake

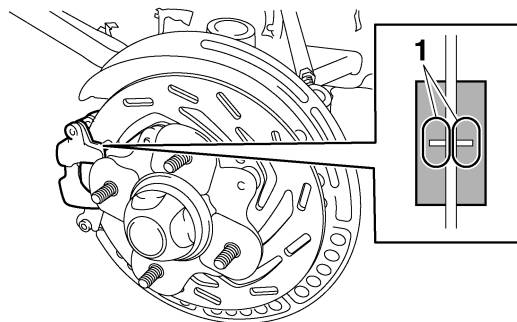

1. Wear indicator groove

Rear brake

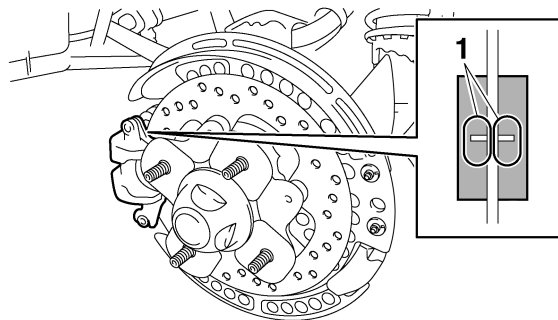

1. Wear indicator groove

Checking the brake fluid level

Before riding, check that the brake fluid is above the minimum level mark. Check the brake fluid level with the top of the reservoir level. Replenish the brake fluid if necessary.

Front brake

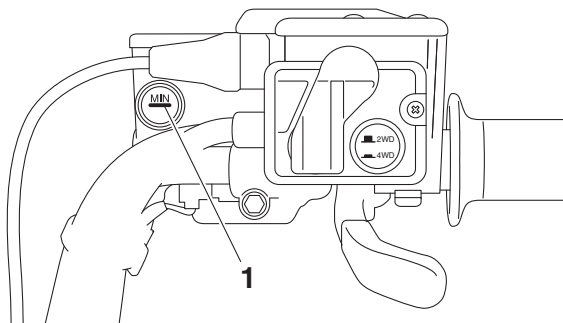

1. Minimum level mark

Rear brake

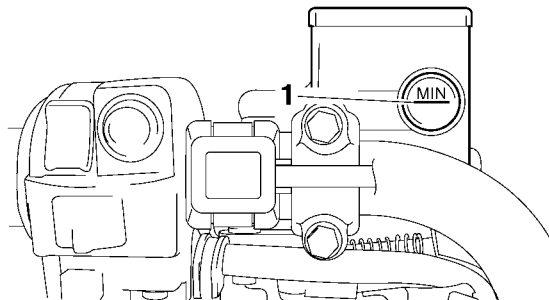

1. Minimum level mark

Specified brake fluid:
DOT 4

EWB02721

WARNING

Improper maintenance can result in loss of braking ability. Observe these precautions:

- **Insufficient brake fluid may allow air to enter the brake system, reducing braking performance.**
- **Clean the filler cap before removing. Use only DOT 4 brake fluid from a sealed container.**

- Use only the specified brake fluid; otherwise, the rubber seals may deteriorate, causing leakage.
- Refill with the same type of brake fluid. Adding a brake fluid other than DOT 4 may result in a harmful chemical reaction.
- Be careful that water does not enter the brake fluid reservoir when refilling. Water will significantly lower the boiling point of the fluid and may result in vapor lock.

ECB01161

NOTICE

Brake fluid may damage painted surfaces or plastic parts. Always clean up spilled fluid immediately.

As the brake pads wear, it is normal for the brake fluid level to gradually go down. A low brake fluid level may indicate worn brake pads and/or brake system leakage; therefore, be sure to check the brake pads for wear and the brake system for leakage. If the brake fluid level goes down suddenly, have a Yamaha dealer check the cause before further riding.

EBU24293

Changing the brake fluid

Have a Yamaha dealer change the brake fluid at the intervals specified in the periodic maintenance and lubrication chart. In addition, have the oil seals of the master cylinders and calipers as well as the brake hoses replaced at the intervals listed below or whenever they are damaged or leaking.

- Oil seals: Replace every two years.
- Brake hoses: Replace every four years.

EBU27773

Checking the front and rear brake lever free play

The front and rear brake lever free play must be checked at the intervals specified in the periodic maintenance and lubrication chart. The brake levers should have no free play as shown. If there is free play, have a Yamaha dealer check the brake system.

Front brake

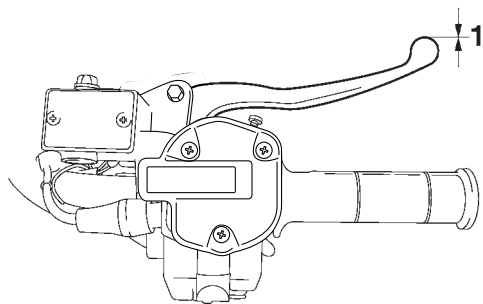

1. No brake lever free play

Rear brake

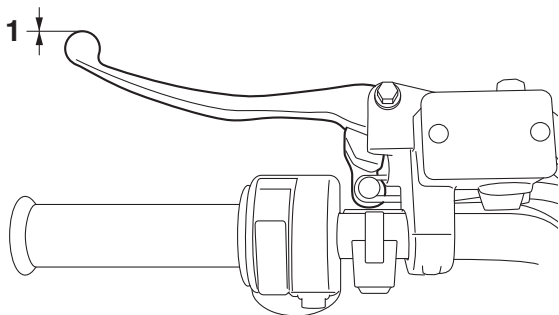

1. No brake lever free play

EBU29074

Adjusting the brake pedal free play

The brake pedal free play must be adjusted at the intervals specified in the periodic maintenance and lubrication chart.

TIP

- Always perform this maintenance completely in the following order whenever adjusting the rear brake.
- Before adjusting the brake pedal free play, check the rear brake pads for wear.

The brake pedal free play should measure 1.0–6.0 mm (0.04–0.24 in) as shown. If the free play is incorrect, adjust it as follows.

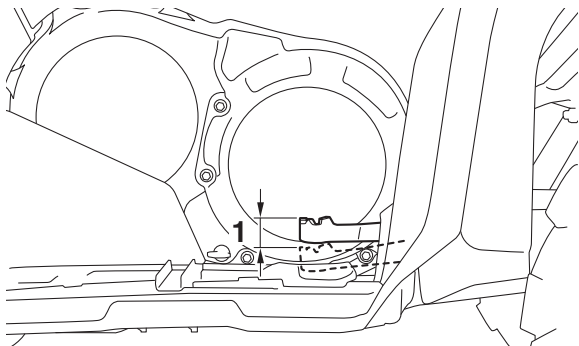

1. Brake pedal free play

1. Remove panel G. (See page 8-10.)
2. Loosen the locknut.
3. Turn the brake pedal free play adjusting nut in direction (a) to increase the free play, and in direction (b) to decrease it.

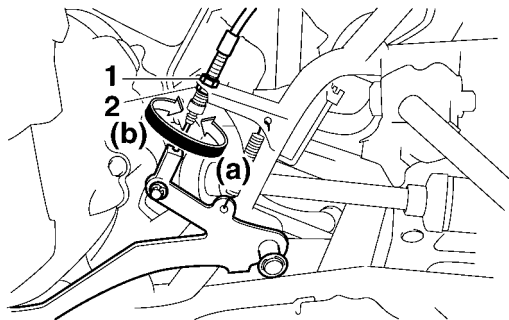

1. Locknut
2. Brake pedal free play adjusting nut
4. Tighten the locknut.
5. After adjusting, there should be slight play at the brake pedal cable joint as shown. If there is no play, repeat steps 2 to 4.

Axle boots

The axle boots must be checked for damage at the intervals specified in the periodic maintenance and lubrication chart. Check the axle boots for tears or damage. If any damage is found, have them replaced by a Yamaha dealer.

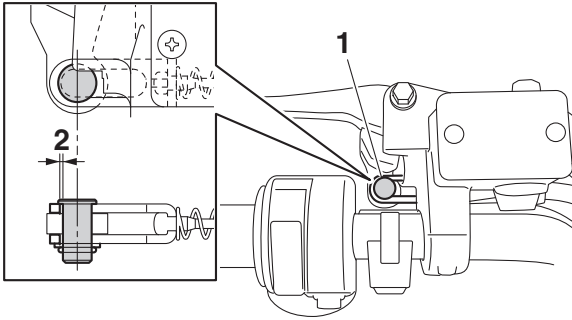

1. Brake pedal cable joint
2. Slight play (0.1–0.5 mm [0.004–0.02 in])

6. Install the panel.

If the correct free play cannot be obtained, have a Yamaha dealer adjust it.

TIP

When adjusting the brake pedal free play:

- Be sure not to step on the brake pedal.
- Make sure the rear brake lever and brake pedal do not move.

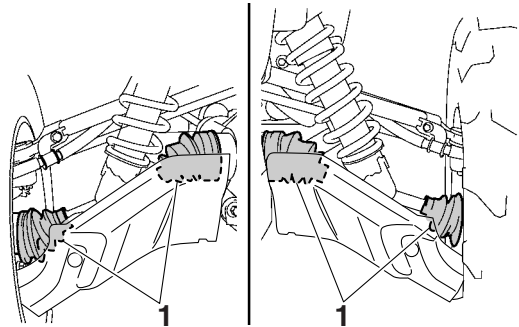

1. Front axle boot (each side)

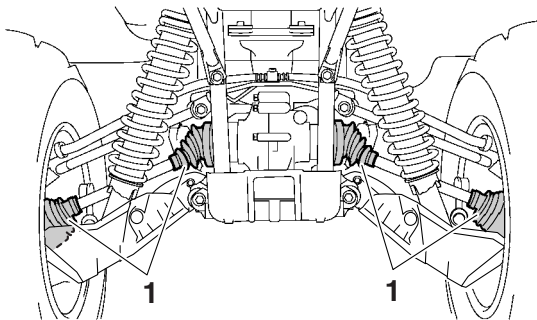

1. Rear axle boot (each side)

EBU24905

Checking and lubricating the cables

The operation and the condition of all control cables should be checked before each ride, and the cables and cable ends should be lubricated if necessary. If a cable is damaged or does not move smoothly, have a Yamaha dealer check or replace it.

Recommended lubricant:

Yamaha cable lubricant or other suitable cable lubricant

EWB02582

WARNING

- **Inspect cables frequently and replace if damaged. Corrosion can result when the cable sheaths become damaged, and cables can also become frayed or kinked, which could restrict the operation of controls and lead to an accident or injury.**
- **Always make sure all control cables work smoothly before you begin riding in cold weather. If the control cables are frozen or do not work smoothly, you could be unable to control the ATV, which could lead to an accident or collision.**

EBU24913

Checking and lubricating the front and rear brake levers

The operation of the front and rear brake levers should be checked before each ride, and the lever pivots should be lubricated if necessary.

Recommended lubricant:

Silicone grease

Front brake lever

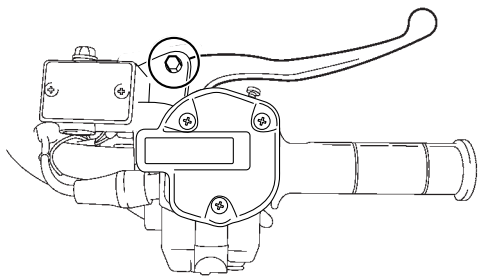

Rear brake lever

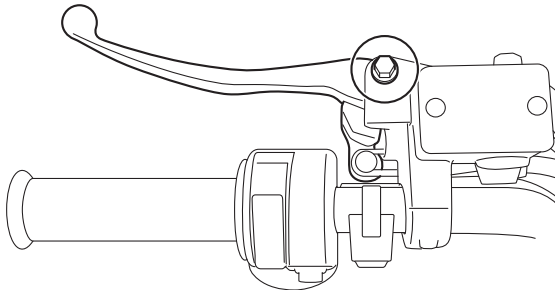

EBU28833

Checking and lubricating the brake pedal

The operation of the brake pedal should be checked before each ride, and the pedal pivot should be lubricated if necessary.

TIP

To access the brake pedal pivot, remove panel G. (See page 8-10.)

Recommended lubricant:
Lithium-soap-based grease

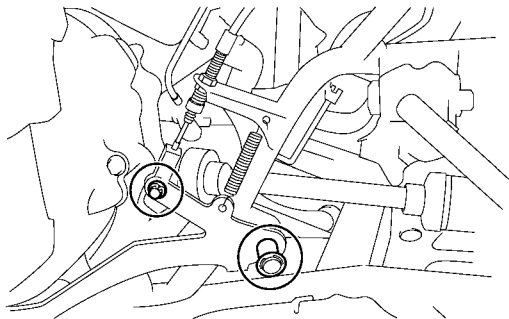

EBU24964

Checking the wheel hub bearings

The front and rear wheel hub bearings must be checked at the intervals specified in the periodic maintenance and lubrication chart. If there is play in a wheel hub or if a wheel does not turn smoothly, have a Yamaha dealer check the wheel hub bearings.

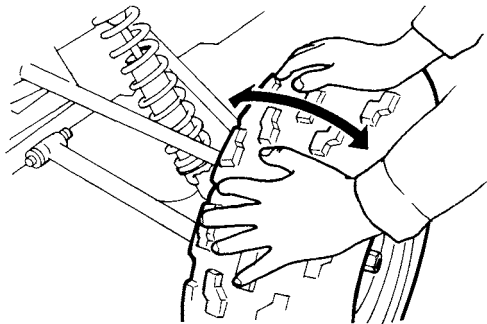

EBU25023

Checking the stabilizer bushes

The stabilizer bushes must be checked for cracks or damage at the intervals specified in the periodic maintenance and lubrication chart.

Have a Yamaha dealer replace the stabilizer bushes if necessary.

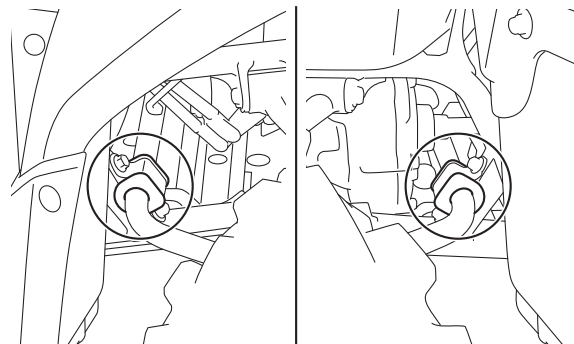

EBU25053

Lubricating the rear knuckle pivots

The rear knuckle pivots must be lubricated at the intervals specified in the periodic maintenance and lubrication chart.

TIP

For parts equipped with a grease nipple, use a grease gun.

Recommended lubricant:
Lithium-soap-based grease

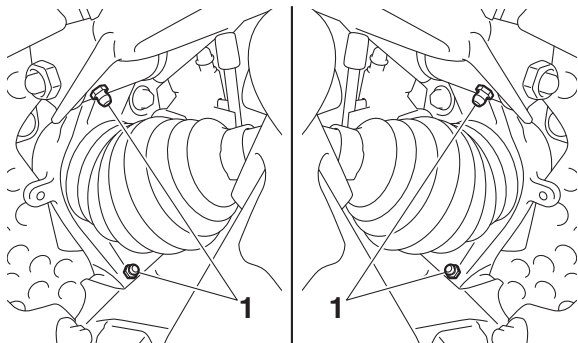

1. Grease nipple

EBU25094

Lubricating the steering shaft

8

The steering shaft must be lubricated by a Yamaha dealer at the intervals specified in the periodic maintenance and lubrication chart.

TIP

For parts equipped with a grease nipple, use a grease gun.

Recommended lubricant:
Lithium-soap-based grease

YFM70GDYG / YFM70GDHG

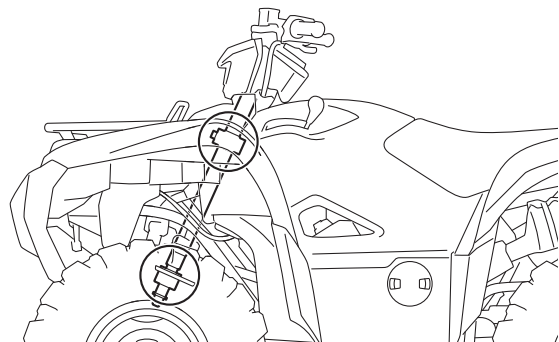

YFM70GPYG / YFM70GPHG / YFM70GPSG /
YFM70GPLG

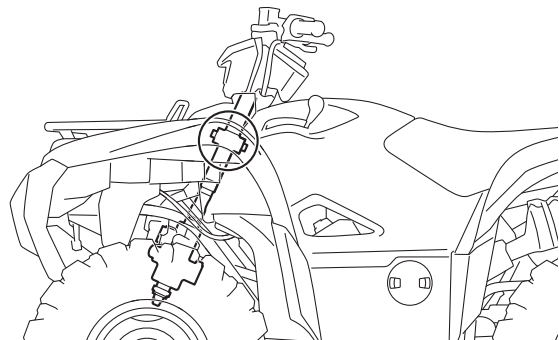

Battery

The battery is located under panel A. (See page 8-10.)

This model is equipped with a VRLA (Valve Regulated Lead Acid) battery. There is no need to check the electrolyte or to add distilled water. However, the battery lead connections need to be checked and, if necessary, tightened.

EWB02161



WARNING

Battery electrolyte is poisonous and dangerous, as it contains sulfuric acid, which can cause severe burns. Avoid contact with skin, eyes or clothing. Always shield your eyes when working near batteries.

Antidote:

EXTERNAL: Flush with water.

INTERNAL: Drink large quantities of water or milk. Follow with milk of magnesia, beaten egg or vegetable oil. Call a physician immediately.

EYES: Flush with water for 15 minutes and get prompt medical attention.

Batteries produce explosive gases. Keep sparks, flame, cigarettes or other sources of ignition away. Ventilate when charging or using in an enclosed space.

KEEP OUT OF REACH OF CHILDREN.

ECB00621

NOTICE

Never attempt to remove the battery cell seals, as this would permanently damage the battery.

To remove the battery

1. Remove panel A. (See page 8-10.)
2. Remove the front carrier by removing the bolts.

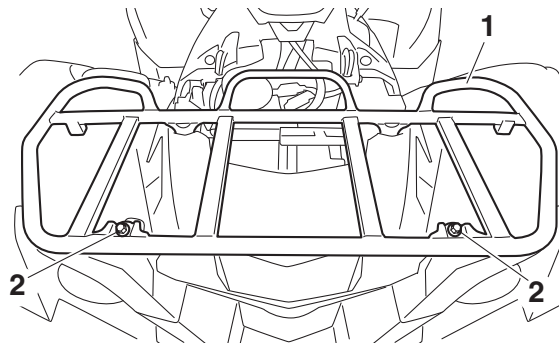

1. Front carrier
2. Carrier bolt (upper)

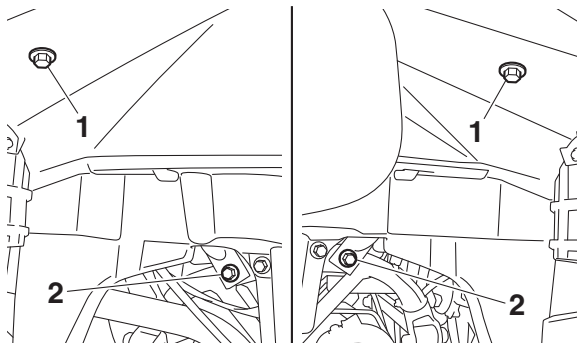

1. Carrier bolt (under the fenders)
2. Carrier bolt (lower)

3. Remove the battery holding plate by removing the nuts.

8

4. Disconnect the negative battery lead first, then the positive battery lead by removing their bolt. **NOTICE: When removing the battery, the main switch must be off, and the negative lead must be disconnected before the positive lead.** [ECB01002]

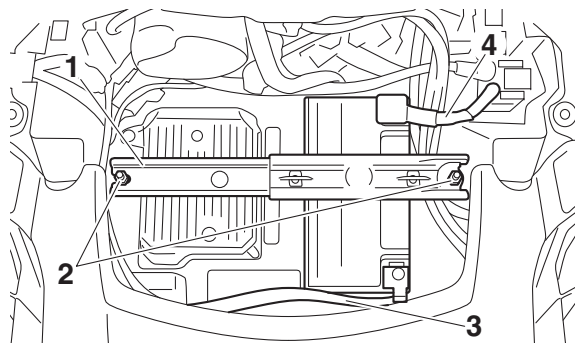

1. Battery holding plate
2. Nut
3. Negative battery lead (black)
4. Positive battery lead (red)

5. Pull the battery out of its compartment.

To charge the battery

Have a Yamaha dealer charge the battery as soon as possible if it seems to have discharged. Keep in mind that the battery tends to discharge more quickly if the ATV is equipped with optional electrical accessories.

NOTICE

To charge a VRLA (Valve Regulated Lead Acid) battery, a special (constant-voltage) battery charger is required. Using a conventional battery charger will damage the battery.

To store the battery

- If the ATV will not be used for more than one month, remove the battery, fully charge it, and then place it in a cool, dry place.
- If the battery will be stored for more than two months, check it at least once a month and fully charge it if necessary.

NOTICE

Always keep the battery charged. Storing a discharged battery can cause permanent battery damage.

To install the battery**TIP**

Be sure the battery is fully charged.

1. Place the battery in its compartment.

2. Connect the positive battery lead first, then connect the negative battery lead by installing their bolt. **NOTICE: When installing the battery, the main switch must be off, and the positive lead must be connected before the negative lead.** [ECB01111]

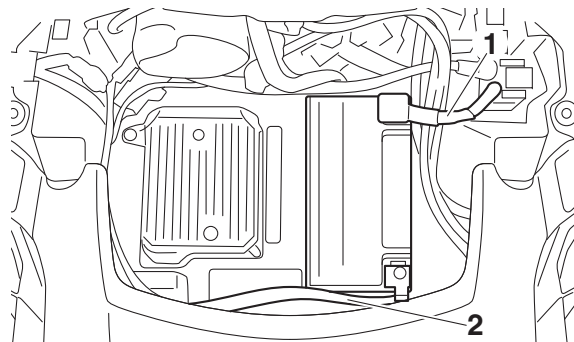

1. Positive battery lead (red)
2. Negative battery lead (black)

3. Install the battery holding plate by installing the nuts.
4. Install the front carrier by installing the bolts and tightening them to the specified torques.

Tightening torques:

Carrier bolt (upper):

34 Nm (3.4 m·kgf, 25 ft·lbf)

Carrier bolt (lower):

34 Nm (3.4 m·kgf, 25 ft·lbf)

Carrier bolt (under the fenders):

7 Nm (0.7 m·kgf, 5.1 ft·lbf)

5. Install the panel.

EBU30521

Replacing a fuse

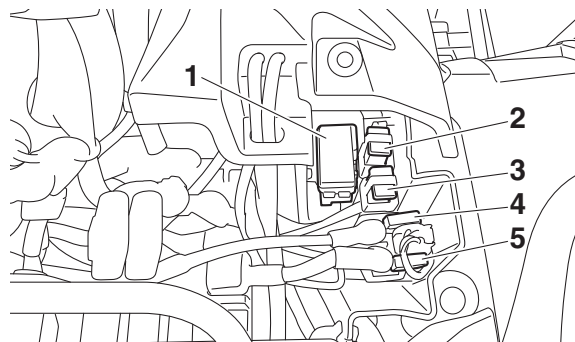

1. Fuse box
2. Main fuse
3. EPS fuse (for EPS model)
4. Fuel injection system spare fuse
5. Fuel injection system fuse

NOTICE

To prevent accidental short-circuiting, turn off the main switch when checking or replacing a fuse.

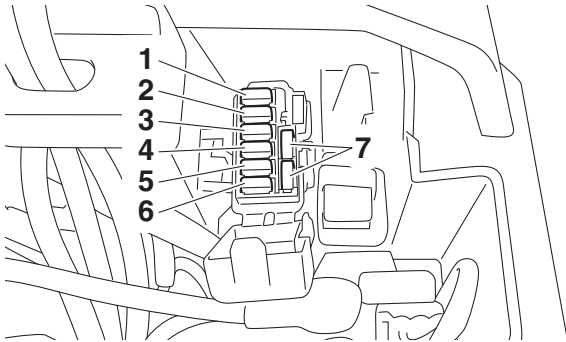

1. Headlight fuse
2. Signaling system fuse
3. Radiator fan motor fuse
4. Ignition fuse
5. Four-wheel-drive motor fuse
6. Auxiliary DC jack fuse
7. Spare fuse

The main fuse, the fuel injection system fuse, the EPS fuse, and the fuse box are located under panel A. (See page 8-10.)

If a fuse is blown, replace it as follows.

1. Turn the key to “” (off) and turn off all electrical circuits.

2. Remove the blown fuse, and then install a new fuse of the specified amperage. **WARNING! Always use a fuse of the specified rating, and never use a substitute object in place of the proper fuse. An improper fuse or a substitute object can cause damage to the electrical system, which could lead to a fire.** [EWB02173]

Specified fuses:

Main fuse:

40.0 A

Headlight fuse:

10.0 A

Ignition fuse:

10.0 A

Four-wheel-drive motor fuse:

10.0 A

Signaling system fuse:

10.0 A

Auxiliary DC jack fuse:

10.0 A

Radiator fan motor fuse:

20.0 A

Fuel injection system fuse:

15.0 A

EPS fuse:

40.0 A (YFM70GPHG, YFM70GPLG,
YFM70GPSG, YFM70GPXG)

3. Turn the key to “ \square ” (on) and turn on the electrical circuits to check if the devices operate.
4. If the fuse immediately blows again, have a Yamaha dealer check the electrical system.

EBU34710

Replacing a headlight bulb**Center headlight**

If the headlight bulb burns out, replace it as follows.

1. Remove the headlight cover by removing the quick fasteners.

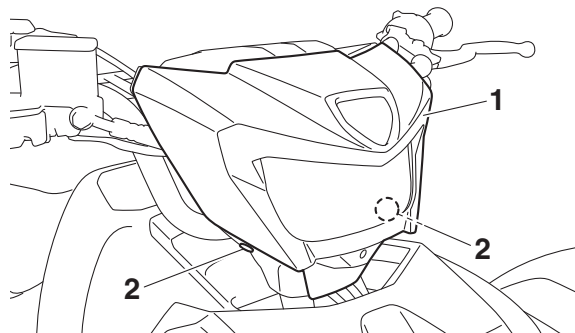

1. Headlight cover
2. Quick fastener

2. Remove the headlight bulb holder cover by pulling it off.

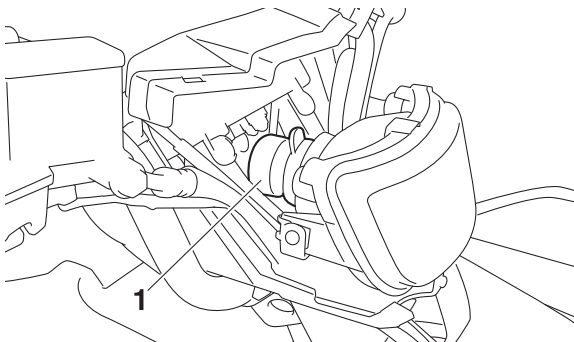

1. Headlight bulb holder cover

3. Remove the headlight bulb holder by pushing it in and turning it counterclockwise.

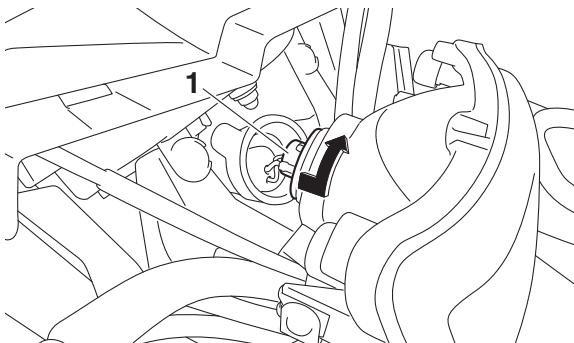

1. Headlight bulb holder

4. Remove the burnt-out bulb.
5. Place a new headlight bulb into position.
NOTICE: Do not touch the glass part of the headlight bulb to keep it free from oil, otherwise the transparency of the glass, the luminosity of the bulb, and the bulb life will be adversely affected. Thoroughly clean off any dirt and fingerprints on the headlight bulb using a cloth moistened with alcohol or thinner. [ECB00652]

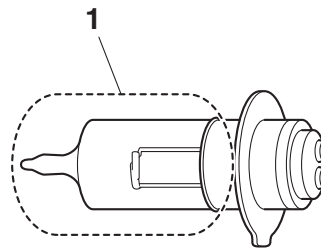

1. Do not touch the glass part of the bulb.
6. Install the bulb holder by pushing it in and turning it clockwise.

7. Install the bulb holder cover. **NOTICE: Make sure the headlight bulb holder cover is securely fitted over the bulb holder and seated properly.** [ECB00672]
8. Install the headlight cover as shown, and then install the quick fasteners.

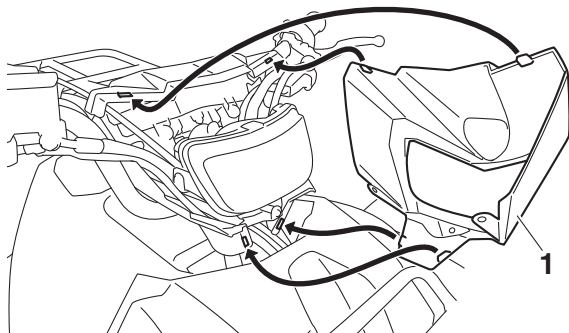

1. Headlight cover

9. Adjust the headlight beam if necessary.

Left and right headlights

This model is equipped with LED-type headlights for the left and right headlights.

If the left or right headlight does not come on, have a Yamaha dealer check it.

EBU25553

Adjusting a headlight beam

ECB00691

NOTICE

It is advisable to have a Yamaha dealer make this adjustment.

To raise a headlight beam, turn the headlight beam adjusting screw in direction (a).

To lower a headlight beam, turn the adjusting screw in direction (b).

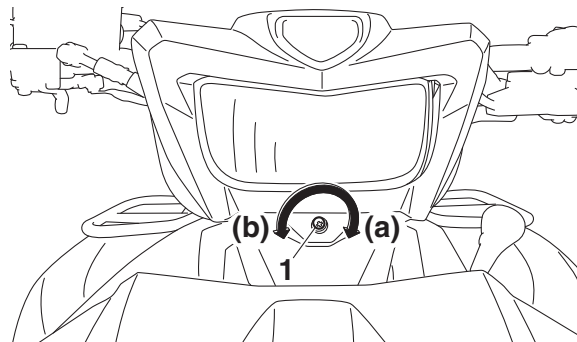

1. Headlight beam adjusting screw

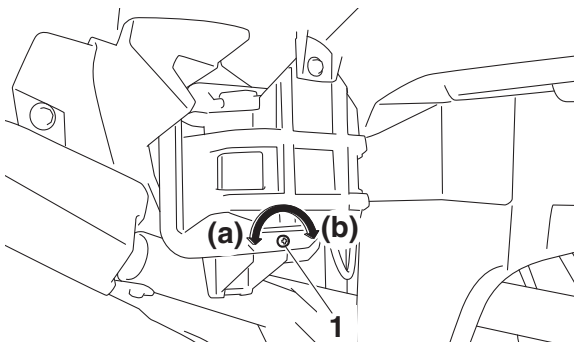

1. Headlight beam adjusting screw

EBU26921

Tail/brake light

This model is equipped with an LED type of tail/brake light.

If the tail/brake light does not come on, have a Yamaha dealer check it.

EBU25652

Removing a wheel

1. Place the ATV on a level surface.
2. Loosen the wheel nuts.

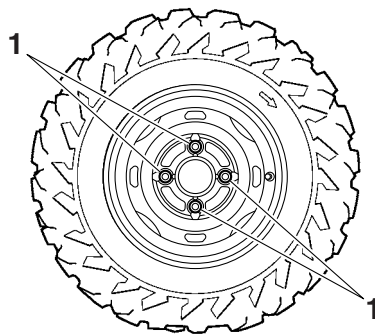

1. Wheel nut

3. Elevate the ATV and place a suitable stand under the frame.
4. Remove the nuts from the wheel.
5. Remove the wheel.

EBU25702

Installing a wheel

1. Place the ATV on a level surface.
2. Install the wheel and the nuts.

TIP

- The arrow mark ⇨ on the tire must point toward the rotating direction of the wheel.

- Tapered nuts are used for both the front and rear wheels. Install the nuts with their tapered side towards the wheel.

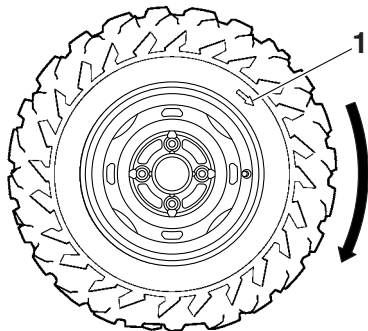

8

1. Arrow mark

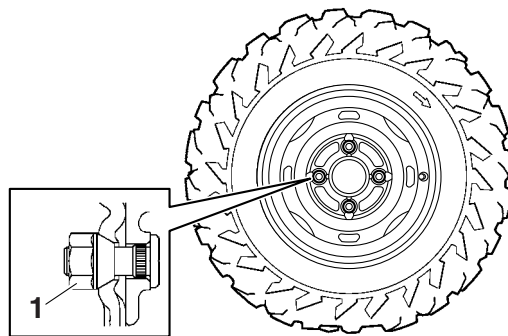

1. Tapered nut

3. Lower the ATV to the ground.
4. Tighten the wheel nuts to the specified torques.

Tightening torques:

Front wheel nut:

55 Nm (5.5 m·kgf, 40 ft·lbf)

Rear wheel nut:

55 Nm (5.5 m·kgf, 40 ft·lbf)

Troubleshooting

Although Yamaha ATVs receive a thorough inspection before shipment from the factory, trouble may occur during operation. Any problem in the fuel, compression, or ignition systems, for example, can cause poor starting and loss of power.

The following troubleshooting charts represent quick and easy procedures for checking these vital systems yourself. However, should your ATV require any repair, take it to a Yamaha dealer, whose skilled technicians have the necessary tools, experience, and know-how to service the ATV properly.

Use only genuine Yamaha replacement parts. Imitation parts may look like Yamaha parts, but they are often inferior, have a shorter service life and can lead to expensive repair bills.

EWB02281



Do not smoke when checking the fuel system. Fuel can ignite or explode, causing severe injury or property damage. Make sure there are no open flames or sparks in the area, including pilot lights from water heaters or furnaces.

Troubleshooting charts

Starting problems or poor engine performance

1. Fuel

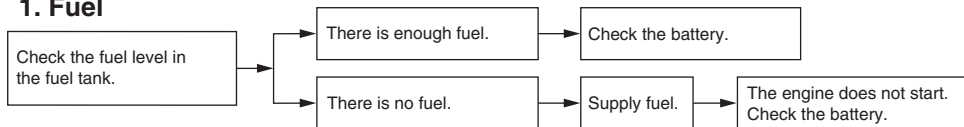

2. Battery

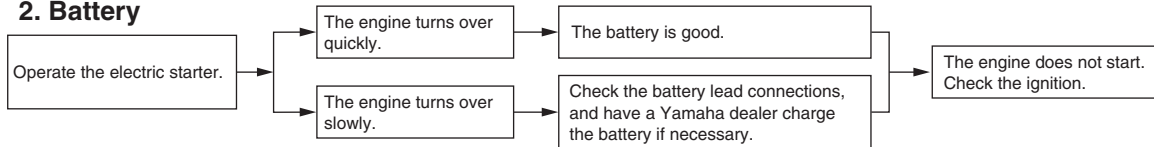

8

3. Ignition

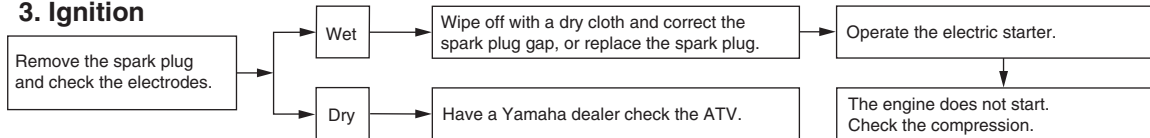

4. Compression

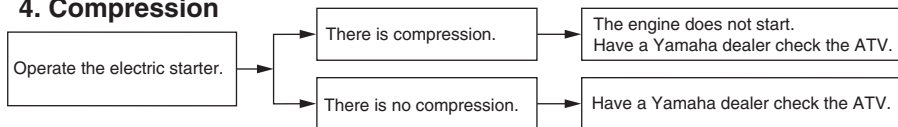

Engine overheating

EWB02291



Wait for the engine and radiator to cool before removing the radiator cap. You could be burned by hot fluid and steam blown out under pressure. Always put a thick rag over the cap when opening. Allow any remaining pressure to escape before completely removing the cap.

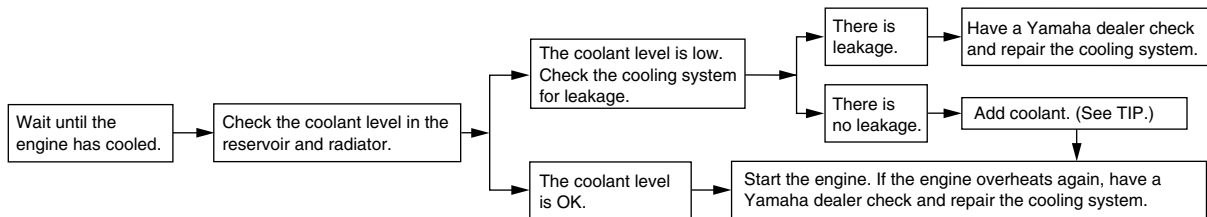

TIP

If coolant is not available, tap water can be temporarily used instead, provided that it is changed to the recommended coolant as soon as possible.

CLEANING AND STORAGE

EBU25882

Cleaning

Frequent, thorough cleaning of your ATV will not only enhance its appearance but will improve its general performance and extend the useful life of many components.

1. Before cleaning the ATV:
 - a. Block off the end of the exhaust pipe to prevent water entry. A plastic bag and strong rubber band may be used.
 - b. Make sure the spark plug and all filler caps are properly installed.
2. If the engine case is excessively greasy, apply degreaser with a paint brush. Do not apply degreaser to the wheel axles.
3. Rinse the dirt and degreaser off with a garden hose. Use only enough pressure to do the job. **WARNING! Wet brakes may have reduced stopping ability, increasing the chance of an accident. Test the brakes after washing. Apply the brakes several times at slow speeds to let friction dry out the linings.** [EWB02312] **NOTICE: Excessive water pressure may cause water seepage**

and deterioration of wheel bearings, brakes, transmission seals and electrical devices. Many expensive repair bills have resulted from improper high-pressure detergent applications such as those available in coin-operated car washers. [ECB00712]

4. Once most of the dirt has been hosed off, wash all surfaces with warm water and mild, detergent-type soap. An old toothbrush or bottle brush is handy for hard-to-reach places.
5. Rinse the ATV off immediately with clean water and dry all surfaces with a chamois, clean towel or soft absorbing cloth.
6. Clean the seat with a vinyl upholstery cleaner to keep the cover pliable and glossy.
7. Automotive type wax may be applied to all painted and chrome plated surfaces. Avoid combination cleaner-waxes. Many contain abrasives which may mar the paint or protective finish. When finished cleaning, start the engine and let it idle for several minutes.

Storage

Short-term

Always store your ATV in a cool, dry place and, if necessary, protect it against dust with a porous cover. **NOTICE: Storing the ATV in a poorly ventilated room or covering it with a tarp while it is still wet, will allow water and humidity to seep in and cause rust. To prevent corrosion, avoid damp cellars, stables (because of the presence of ammonia) and areas where strong chemicals are stored.** [ECB00722]

Long-term

Before storing your ATV for several months:

1. Follow all the instructions in the “Cleaning” section of this chapter.
2. Fill up the fuel tank and add fuel stabilizer (if available) to prevent the fuel from deteriorating.

Specified amount:

7.5 ml of stabilizer to each liter of fuel (or 1 oz of stabilizer to each gallon of fuel)

3. Perform the following steps to protect the cylinder, piston rings, etc. from corrosion.
 - a. Remove the spark plug cap and spark plug.
 - b. Pour a teaspoonful of engine oil into the spark plug bore.
 - c. Install the spark plug cap onto the spark plug, and then place the spark plug on the cylinder head so that the electrodes are grounded. (This will limit sparking during the next step.)
 - d. Turn the engine over several times with the starter. (This will coat the cylinder wall with oil.)
 - e. Remove the spark plug cap from the spark plug, and then install the spark plug and the spark plug cap.
4. Lubricate all control cables and the pivoting points of all levers and pedals.
5. Check and, if necessary, correct the tire air pressure, and then block up the ATV so that all of its wheels are off the ground. Alternatively, turn the wheels a little every month in order to prevent the tires from becoming degraded in one spot.

6. Cover the muffler outlet with a plastic bag to prevent moisture from entering it.
7. Remove the battery and fully charge it. Store it in a cool, dry place and charge it once a month. Do not store the battery in an excessively cold or warm place [less than 0 °C (30 °F) or more than 30 °C (90 °F)]. For more information on storing the battery, see page 8-54.

TIP _____
Make any necessary repairs before storing the
ATV.

SPECIFICATIONS

Dimensions:

- Overall length:
2070 mm (81.5 in)
- Overall width:
1230 mm (48.4 in)
- Overall height:
1253 mm (49.3 in)
- Seat height:
918 mm (36.1 in)
- Wheelbase:
1250 mm (49.2 in)
- Ground clearance:
288 mm (11.3 in)
- Minimum turning radius:
3500 mm (138 in)

Weight:

- Curb weight:
308 kg (679 lb) (YFM70GDHG, YFM70GDYG)
- 314 kg (692 lb) (YFM70GPHG, YFM70GPXG)
- 320 kg (705 lb) (YFM70GPLG, YFM70GPSG)

Noise and vibration level:

- Noise level (77/311/EEC):
80.0 dB(A) at 3125 r/min (EUR)
- Uncertainty of measurement:
3.0 dB(A) (EUR)
- Vibration on seat (EN1032, ISO5008):
Will not exceed 0.5 m/s² (EUR)

Uncertainty of measurement:

- 0.0 m/s² (YFM70GPHG_EUR, YFM70GPLG,
YFM70GPSG_EUR, YFM70GPXG_EUR)
- 0.1 m/s² (YFM70GDHG, YFM70GDYG)
- Vibration on handle (EN1032, ISO5008):
Will not exceed 2.5 m/s² (EUR)

Uncertainty of measurement:

- 0.3 m/s² (EUR)

Engine:

- Engine type:
Liquid cooled 4-stroke, DOHC
- Cylinder arrangement:
Single cylinder
- Displacement:
708 cm³
- Bore × stroke:
103.0 × 85.0 mm (4.06 × 3.35 in)
- Compression ratio:
10.1 : 1
- Starting system:
Electric starter
- Lubrication system:
Wet sump
- Engine oil:**
Recommended brand:
YAMALUBE

Type:

SAE 0W-30, 10W-30, 10W-40, 15W-40, 20W-40 or 20W-50

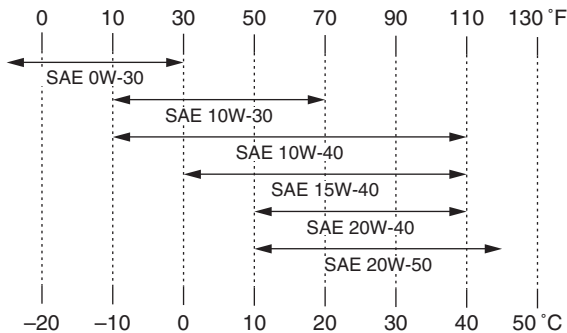

Recommended engine oil grade:

API service SG type or higher, JASO standard MA

Engine oil quantity:

Without oil filter cartridge replacement:

2.00 L (2.11 US qt, 1.76 Imp.qt)

With oil filter cartridge replacement:

2.10 L (2.22 US qt, 1.85 Imp.qt)

Final gear oil:

Type:

Mobilfluid 424

Quantity:

0.20 L (0.21 US qt, 0.18 Imp.qt)

Differential gear oil:

Type:

SAE 80 API GL-4 Hypoid gear oil

Quantity:

0.22 L (0.23 US qt, 0.19 Imp.qt)

Coolant quantity:

Coolant reservoir (up to the maximum level mark):

0.25 L (0.26 US qt, 0.22 Imp.qt)

Radiator (including all routes):

1.76 L (1.86 US qt, 1.55 Imp.qt)

Air filter:

Air filter element:

Wet element

Fuel:

Recommended fuel:

Regular unleaded gasoline only

Fuel tank capacity:

18 L (4.75 US gal, 3.96 Imp.gal)

Fuel reserve amount:

4 L (1.06 US gal, 0.88 Imp.gal)

Fuel injection:

Throttle body:

ID mark:

B161 00

Spark plug (s):

Manufacturer/model:

NGK/CPR7EA-9

Spark plug gap:

0.8–0.9 mm (0.031–0.035 in)

Clutch:

Clutch type:

Wet, centrifugal automatic

Transmission:

Secondary reduction system:

Shaft drive

Secondary reduction ratio:

$43/21 \times 24/18 \times 33/9$ (10.011)

Transmission type:

V-belt automatic

Operation:

Left hand operation

Reverse gear:

$23/14 \times 28/23$ (2.000)

Low range:

$31/16$ (1.938)

High range:

$27/25$ (1.080)

Chassis:

Frame type:

Steel tube frame

Caster angle:

4.53°

Trail:

26.0 mm (1.0 in)

Front tire:

Type:

Tubeless

Size:

AT26 x 8-12

Manufacturer/model:

MAXXIS/MU05Y

Rear tire:

Type:

Tubeless

Size:

AT26 x 10-12

Manufacturer/model:

MAXXIS/MU06Y

Loading:

Maximum loading limit:

240.0 kg (530 lb)

(Total weight of rider, cargo, accessories, and tongue)

Tire air pressure (measured on cold tires):

Recommended:

Front:

35.0 kPa (0.350 kgf/cm², 5.0 psi)

Rear:

30.0 kPa (0.300 kgf/cm², 4.4 psi)

Minimum:

Front:

32.0 kPa (0.320 kgf/cm², 4.6 psi)

Rear:

27.0 kPa (0.270 kgf/cm², 4.0 psi)

Front wheel:

Wheel type:

Cast wheel (YFM70GPLG, YFM70GPSG)

Panel wheel (YFM70GDHG, YFM70GDYG,

YFM70GPHG, YFM70GPXG)

Rim size:

12 x 6.0AT

Rear wheel:

Wheel type:

Cast wheel (YFM70GPLG, YFM70GPSG)
Panel wheel (YFM70GDHG, YFM70GDYG,
YFM70GPHG, YFM70GPXG)

Rim size:

12 x 7.5AT

Front brake:

Type:

Disc brake

Operation:

Right hand operation

Specified brake fluid:

DOT 4

Rear brake:

Type:

Disc brake

Operation:

Left hand and right foot operation

Specified brake fluid:

DOT 4

Front suspension:

Type:

Double wishbone

Spring/shock absorber type:

Coil spring/gas-oil damper

Wheel travel:

193 mm (7.6 in)

Rear suspension:

Type:

Double wishbone

Spring/shock absorber type:

Coil spring/gas-oil damper

Wheel travel:

232 mm (9.2 in)

Electrical system:

Ignition system:

TCI

Charging system:

AC magneto

Battery:

Model:

YTX20L-BS

Voltage, capacity:

12 V, 18.0 Ah

Headlight:

High-mounted headlight bulb type:

Halogen bulb

Bulb voltage, wattage × quantity:

Headlight:

LED

High-mounted headlight:

12 V, 35.0/36.5 W × 1

Tail/brake light:

LED

Meter lighting:

EL (Electroluminescent)

Neutral indicator light:

LED

Reverse indicator light:

LED

Coolant temperature warning light:

LED

EPS warning light:

LED (YFM70GPHG, YFM70GPLG, YFM70GPSG,
YFM70GPXG)

Park indicator light:

LED

Engine trouble warning light:

LED

High-range indicator light:

LED

Low-range indicator light:

LED

Differential gear lock indicator light:

LED

Fuses:

Main fuse:

40.0 A

Fuel injection system fuse:

15.0 A

EPS fuse:

40.0 A (YFM70GPHG, YFM70GPLG, YFM70GPSG,
YFM70GPXG)

Headlight fuse:

10.0 A

Signaling system fuse:

10.0 A

Ignition fuse:

10.0 A

Auxiliary DC jack fuse:

10.0 A

Four-wheel-drive motor fuse:

10.0 A

Radiator fan motor fuse:

20.0 A

EBU30402

For Europe only

The figures quoted are emission levels and are not necessarily safe working levels. Whilst there is a correlation between the emission and exposure levels, this cannot be used reliably to determine whether or not further precautions are required. Factors that influence the actual level of exposure of work-force include the characteristics of the work room, the other sources of noise, etc. i.e. the number of machines and other adjacent processes, and the length of time for which an operator is exposed to the noise. Also the permissible exposure level can vary from country. This information, however, will enable the user of the machine to make a better evaluation of the hazard and risk.

CONSUMER INFORMATION

EBU28202

Identification numbers

Record the vehicle identification number and model label information in the spaces provided below for assistance when ordering spare parts from a Yamaha dealer or for reference in case the ATV is stolen.

VEHICLE IDENTIFICATION NUMBER:

MODEL LABEL INFORMATION:

11 Vehicle identification number

The vehicle identification number is stamped into the frame.

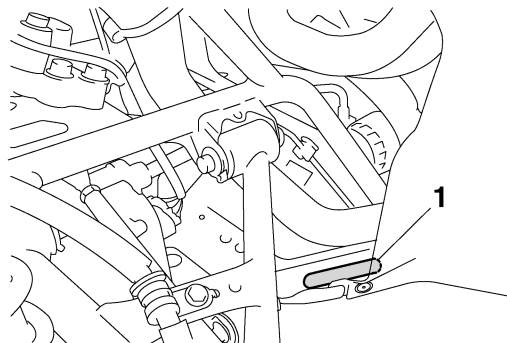

1. Vehicle identification number (front left side)

TIP

The vehicle identification number is used to identify your ATV.

EBU26051

Model label

The model label is affixed at the location in the illustration. Record the information on this label in the space provided. This information will be needed when ordering spare parts from a Yamaha dealer.

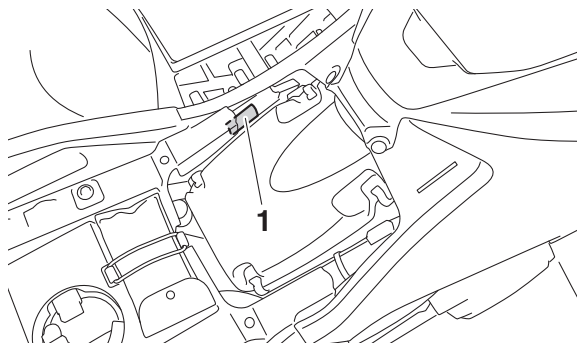

1. Model label

INDEX

A

Accessories and loading	6-6
Accessories, auxiliary jack	4-24
Air filter element, cleaning	8-38
Axle boots	8-49

B

Battery	8-54
Brake fluid, changing	8-46
Brake fluid level, checking	8-45
Brake lever, front	4-14
Brake levers, checking and lubricating	8-50
Brake pads, checking the front and rear	8-44
Brake pedal and rear brake lever	4-14
Brake pedal, checking and lubricating	8-51
Brake pedal free play, adjusting	8-47
Brakes	8-43
Brakes, front and rear	5-3

C

Cables, checking and lubricating	8-50
Carrier, front	4-22
Carrier, rear	4-22
Chassis fasteners	5-6
Cleaning	9-1
Coolant	5-3, 8-30
Coolant temperature warning light	4-3

D

Differential gear oil	5-3, 8-28
Drive select lever	4-15
Drive select lever and driving in reverse	6-2

Drive select lever safety system cable, adjusting	8-43
---	------

E

Engine break-in	6-4
Engine oil	5-3
Engine oil and oil filter cartridge	8-21
Engine stop switch	4-8
Engine trouble warning light	4-3
EPS warning light (for EPS model)	4-4

F

Final gear oil	5-3, 8-25
Four-wheel-drive/differential gear lock indicator	4-4
Front and rear brake lever free play, checking	8-46
Fuel	4-16, 5-3
Fuel tank cap	4-15
Fuses, replacing	8-57

H

Handlebar switches	4-7
Headlight beam, adjusting	8-61
Headlight bulb, replacing	8-59
High-range indicator light	4-2
Horn switch	4-8

I

Identification numbers	11-1
Indicator lights and warning lights	4-2
Instruments, lights and switches	5-7

L

Label locations	1-1
Light switch	4-8
Low-range indicator light	4-2

M			
Main switch	4-1	Speed limiter	4-13
Maintenance and lubrication chart	8-5	Stabilizer bushes, checking	8-52
Maintenance chart, emission control system	8-3	Starting the engine	6-1
Model label	11-1	Start switch	4-8
Multi-function display	4-5	Steering shaft, lubricating	8-53
N		Storage	9-2
Neutral indicator light	4-2	Storage compartments	4-18
O		T	
On-Command differential gear lock switch	4-10	Tail/brake light	8-62
On-Command four-wheel-drive switch	4-9	Throttle lever	4-13, 5-4
Override switch	4-8	Throttle lever free play, adjusting	8-42
Owner's manual and tool kit	8-2	Tires	5-4
P		Trailer hitch (YFM70GPSG / YFM70GPLG)	4-23
Panels, removing and installing	8-10	Troubleshooting	8-64
Park indicator light	4-2	Troubleshooting charts	8-65
Parking	6-5	V	
Parking on a slope	6-5	Valve clearance	8-43
Part locations	3-1	V-belt case drain plug	8-42
R		Vehicle identification number	11-1
Rear knuckle pivots, lubricating	8-52	W	
Reverse indicator light	4-2	Wheel hub bearings, checking	8-52
Riding your ATV	7-1	Wheel, installing	8-62
S		Wheel, removing	8-62
Safety information	2-1		
Seat	4-17		
Shock absorber assemblies, adjusting the front and rear	4-22		
Spark arrester, cleaning	8-40		
Spark plug, checking	8-18		
Specifications	10-1		

⚠ WARNING

Improper ATV use can result in SEVERE INJURY or DEATH.



**ALWAYS USE
AN APPROVED
HELMET AND
PROTECTIVE GEAR**



**NEVER USE
ON PAVED
ROADS**



**NEVER CARRY
PASSENGERS**



**NEVER USE
WITH DRUGS
OR ALCOHOL**

NEVER operate:

- without proper training or instruction.
- at speeds too fast for your skills or the conditions.
- on public roads—a collision can occur with another vehicle.
- with a passenger—passengers affect balance and steering and increase risk of losing control.

ALWAYS:

- use proper riding techniques to avoid vehicle overturns on hills and rough terrain and in turns.
- avoid paved surfaces—pavement may seriously affect handling and control.

LOCATE AND READ OWNER'S MANUAL. FOLLOW ALL INSTRUCTIONS AND WARNINGS.

